



SAMSUNG

Commercial

**Product
Catalogue**

Samsung Climate Solutions help people find their flow

Samsung Climate Solutions aims to help people find their flow, so they may feel and live their best life – be it at work, play or rest. We are committed to offering more energy-efficient solutions with innovative cooling, heating, domestic hot water, refrigeration and smart building solutions. For every space where people create memorable experiences together, be it commercial spaces or residential homes.

We offer:



Ventilation



Hot water



Cooling



Heating

Services we provide to empower our partners:



Expert
training



Project
design



Technical
support



Marketing
platforms



Spare
parts



WindFree™



WindFree™ Cooling

SmartThings



Wi-Fi Control

b. IoT



Building Management System

**Our flagship
innovations that
enrich people's lives**

Product overview

VRF (DVM)

A Samsung VRF air conditioning system offers high installation flexibility with the new DVM S2 platform outdoor units, which can connect to up to 64 indoor units. This is an ideal solution for medium-sized to large commercial buildings, with the option of independently cooling or heating multiple rooms simultaneously.

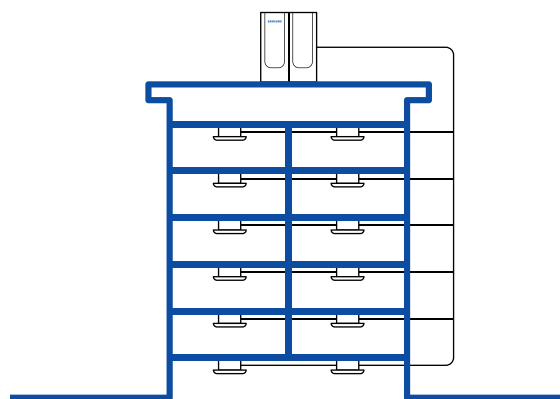

VRF Chiller (HVM)

A Samsung VRF Chiller air conditioning system follows a modular concept with the option of combining up to 16 HVM outdoor units to form one climate solution, which can be connected to a wide range of Fan Coil Units. The system utilises water for comfortable cooling and heating of any type of space.

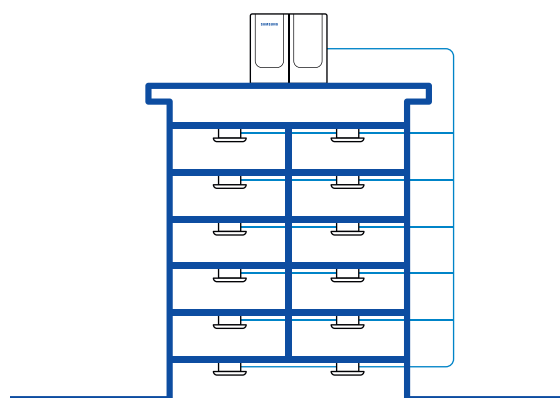

Ventilation (ERV)

A Samsung ERV system brings fresh outside air into a room to optimise indoor air quality, while automatically adjusting its operation mode in accordance with indoor and outdoor temperatures. It can be connected to a Samsung VRF system to form a total climate solution.

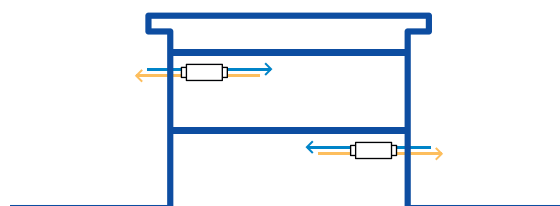

Available Samsung product range

indoor units

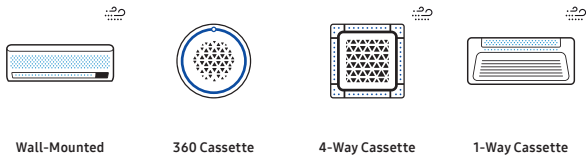

Wall-Mounted 360 Cassette 4-Way Cassette 1-Way Cassette

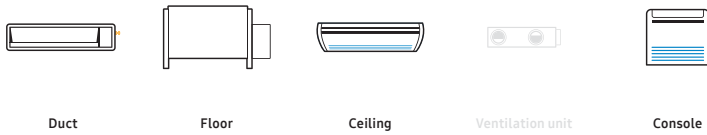

Duct Floor Ceiling Ventilation unit Console

outdoor units

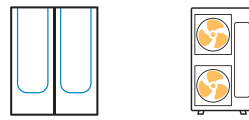

VRF Mini VRF



Water system Hydro unit

controls



Wireless Wired



Centralised

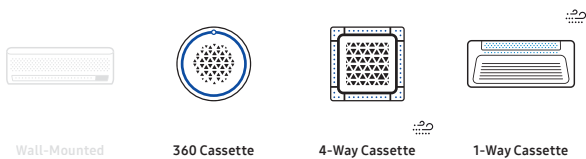

Wall-Mounted 360 Cassette 4-Way Cassette 1-Way Cassette

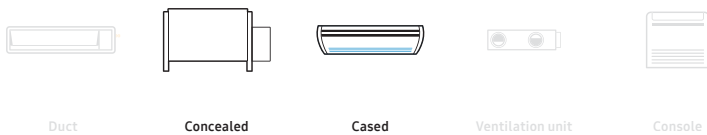

Duct Concealed Cased Ventilation unit Console

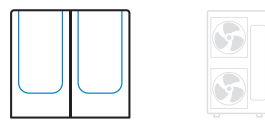

Large VRF Chiller Mini VRF



Water system Hydro unit



Wireless Wired



Centralised

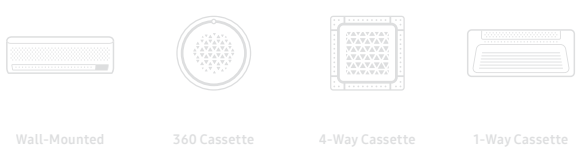

Wall-Mounted 360 Cassette 4-Way Cassette 1-Way Cassette



Duct Floor Ceiling Ventilation unit Console

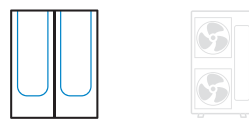

Large VRF Mini VRF

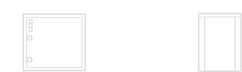

Water system Hydro unit

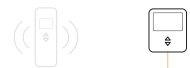

Wireless Wired



Centralised

Schematic drawings are for illustrative purposes only. For accurate installation information please consult the technical data book. The selection of the exact product is subject to specific application conditions. FCU = Fan Coil Unit. For more detailed product information and technical specifications, please consult the respective product pages of this Product Catalogue.

Table of contents



2

Introduction

- Samsung Climate Solutions
- Product overview
- Milestones
- Highlights
- Airzone
- b.IoT Lite
- Reference Projects
- Regulations
- Certifications



30

VRF

- Line-up outdoor
- Selection guide
- Nomenclature
- DVM S Mini **NEW**
- DVM S
- DVM S2
- Heat Recovery for DVM
- DVM S Water



78

Indoor Units VRF

- Line-up indoor **NEW**
- WindFree™ 4-Way Cassette **UNIQUE**
- WindFree™ 1-Way Cassette **UNIQUE**
- 360 cassette
- LSP Slim Duct
- MSP/HSP Duct S
- WindFree™ Deluxe **UNIQUE**
- DVM Hydro Unit
- Air Handling Unit (AHU) Kit
- Drawings



226

VRF Chillers

- Line-up
- Combination guide
- Selection guide
- Nomenclature
- HVM Chiller
- WindFree™ 1&4-Way Cassette
- Drawings

260

Ventilation

- ERV (Plus)
- Drawings



272

Controls

- Touch Centralized Controller 2.0
- Line-up
- Compatibility guide
- Selection guide
- Features and dimensional drawings

288

Accessories

Line-up **NEW**



294

Design and support

- Climate Solutions Partner Portal
- DVM Pro 2.0
- HVM Selection Tool
- Specialist design support
- Climate Solutions Academy

This document may either contain preliminary values or may lack some values that were not yet available at the time of creation. To obtain the latest information, please consult the Samsung Climate Solutions Partner Portal at partnerhub.samsung.com/climate or contact your Samsung representative.

Corporate and Technology milestones that make us proud

1974

Samsung introduces its first air conditioner.



2005

Samsung Electronics enters the European market for commercial air conditioning.



2014

Arrival of the Samsung TDM concept, an all-in-one heat pump solution for heating, cooling and domestic hot water supply.

2015

Introduction of the Samsung 360 Cassette, the world's first circular air conditioner that fits seamlessly into the design of any space.



Our market-centric product ranges

Home	Apartments	Hotel	Retail	Office	Education	Restaurant	
RAC FJM	RAC FJM DVM						Residential
CAC FJM	CAC FJM DVM				CAC		Light Commercial
			DVM HVM ERV			DVM	Commercial
EHS							Heating
Controls							Controls

2017

Samsung Electronics opens Samsung Electronics Air Conditioner Europe B.V. (SEACE) in Amsterdam.



Samsung WindFree™ technology comes onto the market, gently and evenly dispersing fresh air through thousands of micro-holes to limit cold drafts.



2021

Samsung launches the sixth generation of its Digital Variable Multi the DVM S2 equipped with AI technology, enhanced energy efficiency performance, easier installation and serviceability.

2025

The introduction of Samsung's DVM S Mini, an advanced heating and cooling system that has a smaller environmental footprint thanks to the use of the new generation R32 refrigerant.



Our European footprint with the locations from which we operate

- 1 | Samsung Electronics Air Conditioner Europe B.V.
- 16 | Samsung offices
- 8 | Warehouses
- 10 | Training centres



Highlights | DVM S Mini

Safety, durability and innovation

The new DVM S Mini R32 has it all

The DVM S Mini with R32 refrigerant is an advanced heating and cooling system that is not only efficient, but also adaptive to the evolving demands of industry. It has a lower Global Warming Potential (GWP) compared to the previous refrigerant R410A¹. Its small footprint, light weight and unimposing design make it ideal for residential and light commercial environments.



A stand-out feature is its seamless integration of artificial intelligence (AI) and the compatibility with Samsung building management software b.IoT. At the heart of its innovation is Active AI. One of the features is AI Refrigerant Analysis, which harnesses the power of deep learning to monitor and analyze operational data in real-time and pro-actively alerts its users if a discrepancy occurs. The system is also equipped with AI Pressure Control⁴, which learns usage patterns from recent operations and the surrounding conditions.

Each indoor cassette unit comes with a factory-integrated Wi-Fi kit (MIM-H14EN) for effortless management through the intuitive SmartThings App⁵.



VIDEO
DVM S Mini
High Pressure Control



VIDEO
DVM S Mini
Low Pressure Control



The system combines maximum flexibility with adherence to IEC 60335-2-40 safety standards. The outdoor unit is equipped with a shut-off valve and battery pack, while the indoor unit features a built-in R32 refrigerant leak detect sensor. The wireless remote controller² has an audible and visible alarm system to alert users in the event of leakage.



VIDEO
DVM S Mini
Emergency

¹ GWP R32: 675 GWP R410A: 2088 R32 refrigerant charge 2.2kg tCO₂e=1.49 R410A refrigerant charge 2.00 & 2.5 kg tCO₂e=4.18 & 5.22.

² Only available for model codes: MWR-WG01JN and MWR-WG01KN.

³ Based on internal testing of the cooling operation, with the temperature set at 22°C and using Auto mode for 4 hours, at a room temperature of 33°C and an external temperature of 35°C. The tested model was an AM080AXVGGH/EU connected to AM083NN4DBH1 and AM145NN4DBH1 indoor units with 25m of piping. The elapsed times were measured when the room temperature reached 25°C.

⁴ Samsung SmartThings application account and internet connection are required. Requires iOS 10.0 or later & Android 5.0 or later.



Smart Control

The DVM S Mini R32 enhances the user experience with Wi-Fi-enabled control, thanks to the factory-integrated Single Wi-Fi kit (MIM-H14EN). This allows for effortless management through the intuitive SmartThings App¹ and empowers users to monitor energy usage and adjust settings on-the-go, ensuring a harmonious balance between comfort and energy usage².

¹ Samsung SmartThings application account and internet connection are required. Requires iOS 10.0 or later & Android 5.0 or later.
² Available in selected models only.

Samsung b.IoT Lite ready

Samsung b.IoT (building Internet of Things) is a building management solution that can efficiently manage and help to save energy. It's an open platform with expandability and compatibility options that enable integrated control of the facility's major systems. The synergy between the DVM S Mini R32 and b.IoT Lite paves the way for streamlined installations, optimised energy management, and efficient operations, all while maintaining comprehensive oversight of integrated systems.



SolarCell Remote Controller

Samsung introduces the SolarCell Remote controller to its commercial air conditioning line-up. The new SolarCell remote controller focuses on innovative charging, slim design and easy usability features. The SolarCell remote controller does not need batteries; instead a solar panel is integrated on the back of the remote controller that allows charging by exposing it under direct light. A single, fully charged battery can last up to two years, making it an economical alternative to disposable batteries. In addition, there is also a USB-C port on the bottom of the remote control for fast charging. It has better grip, easier button controls, large OLED display and it is lightweight¹.

¹ Compared to the conventional infrared remote controller for example, the AR-EH03.



Active AI

Active AI Pressure Control

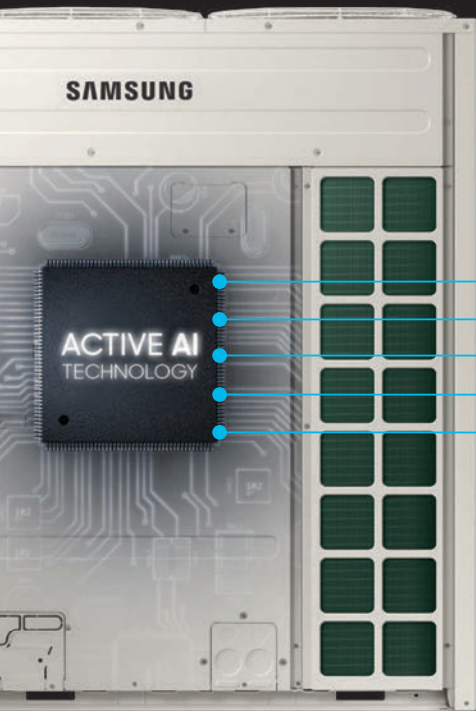

-  Fan speed of Indoor units
-  Number of Indoor units
-  Frequency of simultaneous use
-  Set temp.
-  Room temp.

Optimal cooling by learning usage patterns

By learning usage patterns from recent cooling operations and the surrounding conditions, the DVM S2 and DVM S Mini proactively create the optimal cooling environment to suit users' general requirements. For example: (1) If a user frequently lowers the room temperature when turning on the air conditioner, the Active AI Pressure Control recognizes this pattern. So, when the air conditioner is turned on again, it automatically lowers the pressure of the inflow refrigerant by up to 33% and cools up to 20% faster*. (2) However, if there's no need for fast cooling, it saves energy by adjusting the refrigerant pressure to be higher than normal.

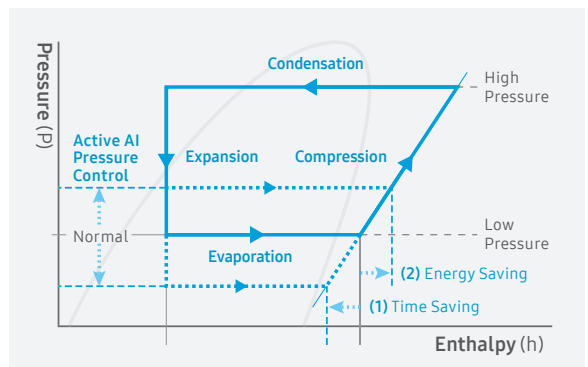
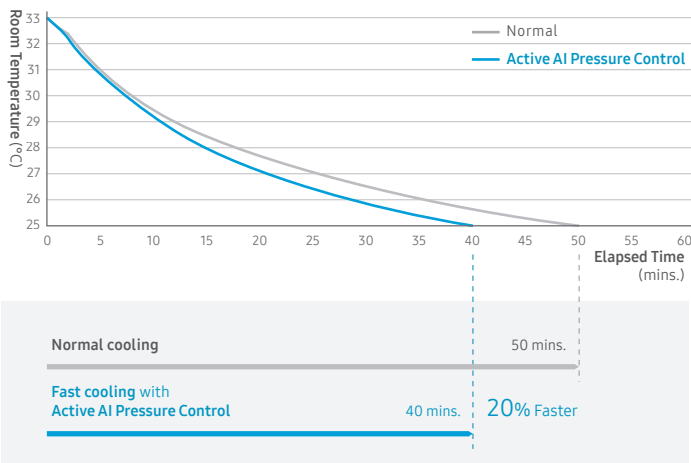

* Based on internal testing of the cooling operation, with the temperature set at 22°C and using Auto mode for 4 hours, at a room temperature of 33°C and an external temperature of 35°C. The tested model was an AM060DXMDKG/EU connected to AM140DN4DKG/EU indoor unit with 25m of piping. The elapsed times were measured when the room temperature reached 25°C.

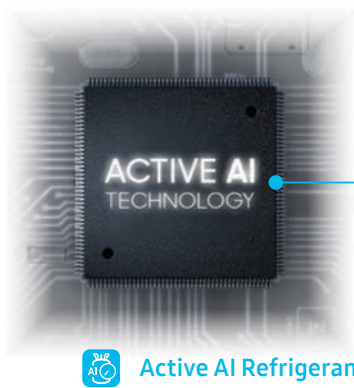

Active AI Refrigerant Analysis

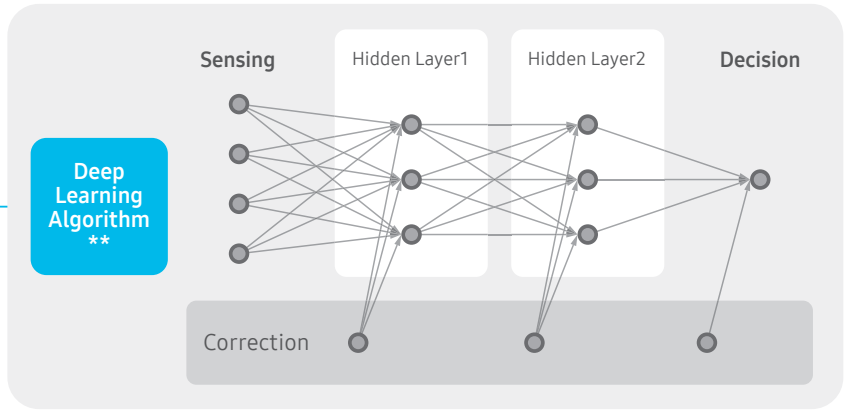

Maintains the optimal amount of refrigerant to ensure the best performance

Shortage of refrigerant hinders the outdoor unit's cooling and heating performance as well as its energy efficiency. And, if refrigerant leaks out, due to any error in installation, operation or maintenance, it also impacts global warming and may even cause the system to stop working. Using Deep Learning

technology*, the Active AI Refrigerant Analysis of the DVM S2 and DVM S Mini collects and analyzes various operational data in real time, and proactively alerts you with an error message if the amount of refrigerant is too low. So, an installer or a service engineer can maintain the optimal level of refrigerant.

* A Machine Learning technology that uses an Artificial Neural Network (ANN) to learn like a human using various data.
 ** Based on a research thesis, "A novel hybrid deep neural network model to predict the refrigerant charge amount of heat pumps".

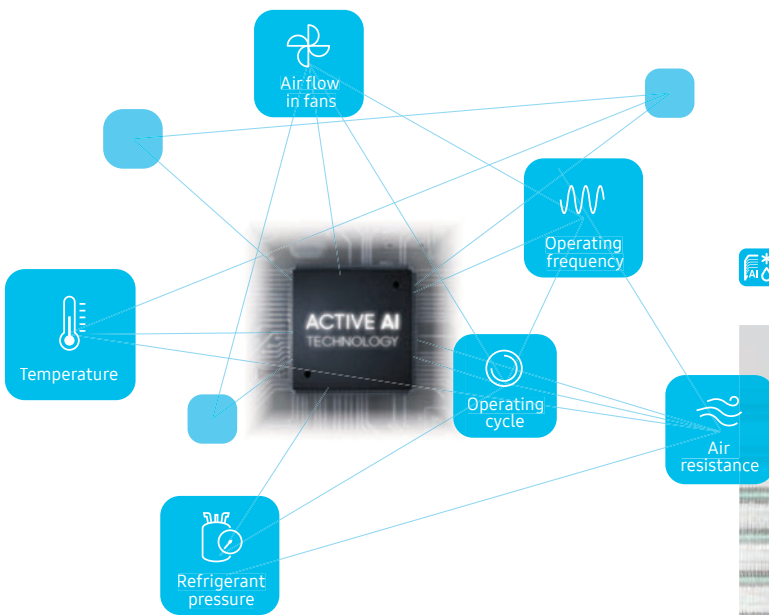

Active AI Defrost

Heats for longer with less defrosting

The heating operation generally causes ice to build up on outdoor units, which may interfere with the heat exchange process. To remove any ice, air conditioning systems normally pause the heating and run a defrost operation, so the indoor environment feels less comfortable. Samsung's Active AI* Defrost technology analyzes various operating data, including the system's air resistance, operating frequency and cycle, so it defrosts more precisely. As a result, it reduces wasted energy and increases the continuous heating time by up to 40%*.

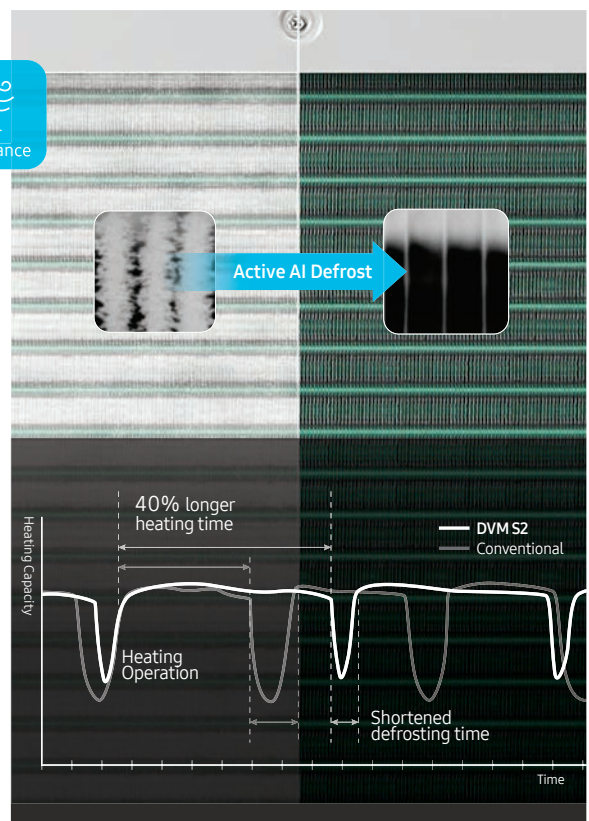

Airzone



Integrated Zoning Solution

Airzone provides centralised control and improvement in energy performance to Samsung ducted applications. This third party solution offers the possibility to control the temperature of up to 8 zones or rooms separately. The Airzone plenum with dampers determines the required airflow to each room to meet the desired temperature.

Airzone's multiple zoning control solution can be easily connected to Samsung's ducted systems and allows for a reduction in maintenance operations and refrigerant charge compared to installing separate AC units for each zone. Unlike other third party solutions, Airzone uses Samsung's communication protocol to control the needed airflow. If there is no demand, the indoor unit is stopped. This avoids unwanted operation; therefore increases the energy efficiency of the system.

Flexibility and Smart Operation

The integrated zoning system from Airzone with smart control allows for optimized energy efficiency, as temperatures in the different zones can be independently

controlled. This translates into energy efficiency since the AC unit will not unnecessarily cool or heat unoccupied zones.

Each damper is controlled by an Airzone room controller either wired or wireless. In addition, Airzone also allows controlling the room temperature remotely with the Airzone Cloud App¹, Google Assistant^{2,3} and Amazon Alexa^{2,4}.



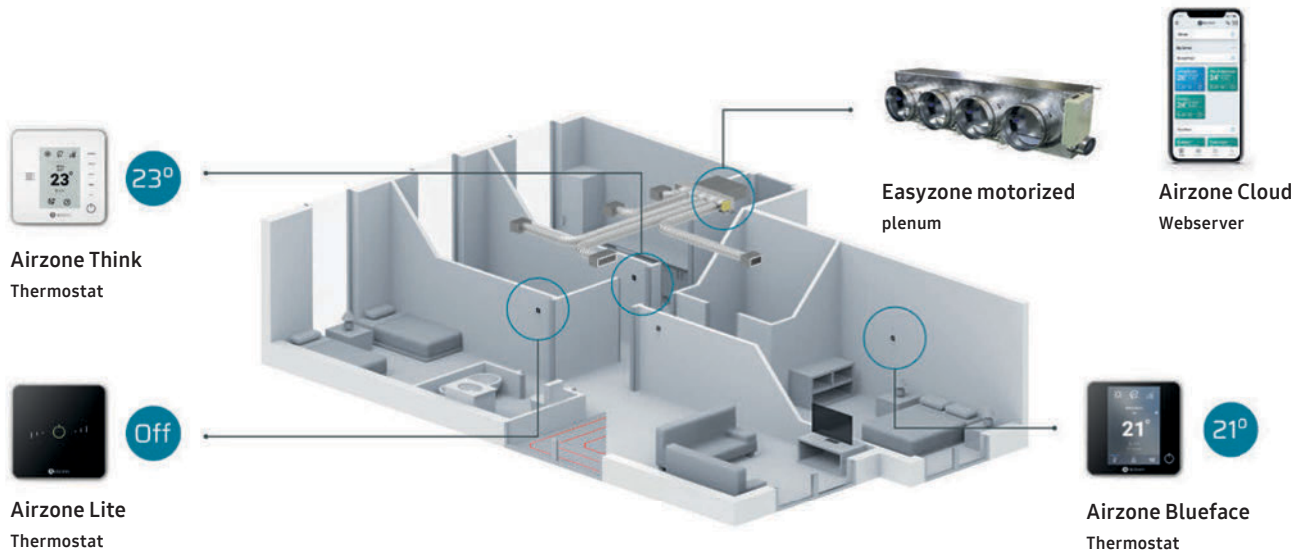

- ¹ Available for iOS and Android
- ² Voice control is supported by AI speakers; Google Assistant (Google Home) and Amazon Alexa
- ³ Google Assistant is not available in certain languages and countries. Google is a trademark of Google LLC
- ⁴ Airzone is not compatible with SmartThings and SmartThings App



Airzone⁵ compatible models

Product Group	Samsung Model Code	Detail	Dimensions (W×H×D)	3 Port	4 Port	5 Port	6 Port	8 Port
DVM	AM017ANLDKH/EU	DUCT LSP 1.7kW	700×199×440	AZEZ8SAMSLO3S3				
DVM	AM022ANLDKH/EU	DUCT LSP 2.2kW	700×199×440	AZEZ8SAMSLO3S3				
DVM	AM028ANLDKH/EU	DUCT LSP 2.8kW	700×199×440	AZEZ8SAMSLO3S3				
DVM	AM036ANLDKH/EU	DUCT LSP 3.6kW	700×199×440	AZEZ8SAMSLO3S3				
DVM	AM045ANLDKH/EU	DUCT LSP 4.5kW	900×199×440		AZEZ8SAMSLO3M4			
DVM	AM056ANLDKH/EU	DUCT LSP 5.6kW	900×199×440		AZEZ8SAMSLO3M4			
DVM	AM071ANLDKH/EU	DUCT LSP 7.1kW	1100×199×440			AZEZ8SAMSLO3L5		
DVM	AM090ANLDKH/EU	DUCT LSP 9kW	1300×295×690			AZEZ8SAMST04L5	AZEZ8SAMST04L6	AZEZ8SAMST04L8
DVM	AM017DNLDKG/EU	DUCT LSP 1.7kW	700×199×440	AZEZ8SAMSLO3S3				
DVM	AM022DNLDKG/EU	DUCT LSP 2.2kW	700×199×440	AZEZ8SAMSLO3S3				
DVM	AM028DNLDKG/EU	DUCT LSP 2.8kW	700×199×440	AZEZ8SAMSLO3S3				
DVM	AM036DNLDKG/EU	DUCT LSP 3.6kW	700×199×440	AZEZ8SAMSLO3S3				
DVM	AM045DNLDKG/EU	DUCT LSP 4.5kW	900×199×440		AZEZ8SAMSLO3M4			
DVM	AM056DNLDKG/EU	DUCT LSP 5.6kW	900×199×440		AZEZ8SAMSLO3M4			
DVM	AM071DNLDKG/EU	DUCT LSP 7.1kW	1100×199×440			AZEZ8SAMSLO3L5		
DVM	AM022DNMDKG/EU	DUCT MSP 2.2kW	850×250×700	AZEZ8SAMST06XS3				
DVM	AM028DNMDKG/EU	DUCT MSP 2.8kW	850×250×700	AZEZ8SAMST06XS3				
DVM	AM036DNMDKG/EU	DUCT MSP 3.6kW	850×250×700	AZEZ8SAMST06S3	AZEZ8SAMST06S4			
DVM	AM045DNMDKG/EU	DUCT MSP 4.5kW	850×250×700	AZEZ8SAMST06S3	AZEZ8SAMST06S4			
DVM	AM056DNMDKG/EU	DUCT MSP 5.6kW	850×250×700	AZEZ8SAMST06S3	AZEZ8SAMST06S4			
DVM	AM071DNMDKG/EU	DUCT MSP 7.1kW	850×250×700	AZEZ8SAMST06M3	AZEZ8SAMST06M4	AZEZ8SAMST06M5	AZEZ8SAMST06M6	
DVM	AM090DNMDKG/EU	DUCT MSP 9kW	1200×250×700			AZEZ8SAMST06L5	AZEZ8SAMST06L6	AZEZ8SAMST06L8
DVM	AM112DNMDKG/EU	DUCT MSP 11.2kW	1300×300×700					AZEZ8SAMST06XL8
DVM	AM128DNMDKG/EU	DUCT MSP 12.8kW	1300×300×700					AZEZ8SAMST06XL8
DVM	AM140DNMDKG/EU	DUCT MSP 14kW	1300×300×700					AZEZ8SAMST06XL8

Communication gateway for all models: AZX6GTCSA2

⁵ Airzone is a third party and not part of Samsung. Airzone Plenum with damper, wired & wireless thermostats and gateway, can be purchased directly from Airzone website: <https://www.airzonecontrol.com/> or contacting the Airzone sales team at sales@airzonecontrol.com

b.IoT Lite

Samsung b.IoT (building Internet of Things) is a building management solution that can efficiently manage and save energy. It is an open platform with expandability and compatibility options that enable integrated control of the facility's major systems, such as VRF and third-party party devices via BACnet interface.

Samsung b.IoT Lite helps to ensure:

- Efficient installation periods
- Reductions in installation and operation costs
- Optimal energy efficiency
- Efficient management of integrated systems installed in the building

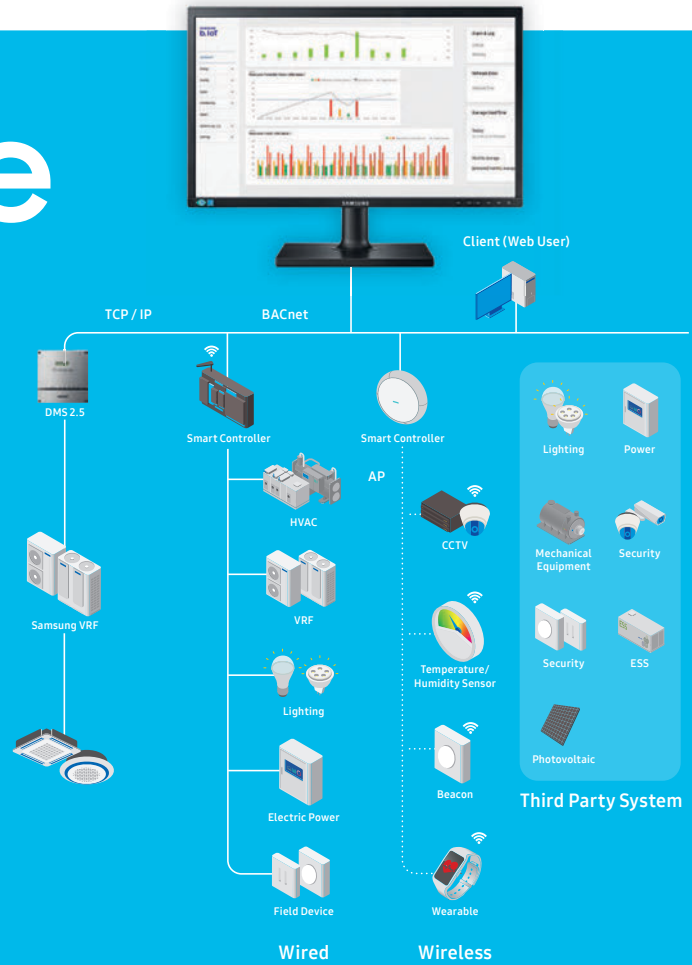

* This picture refers to b.IoT Enterprise features
Smart Controller, IoT AP, Wireless Devices are available for Korean market only

Samsung b.IoT Lite provides:

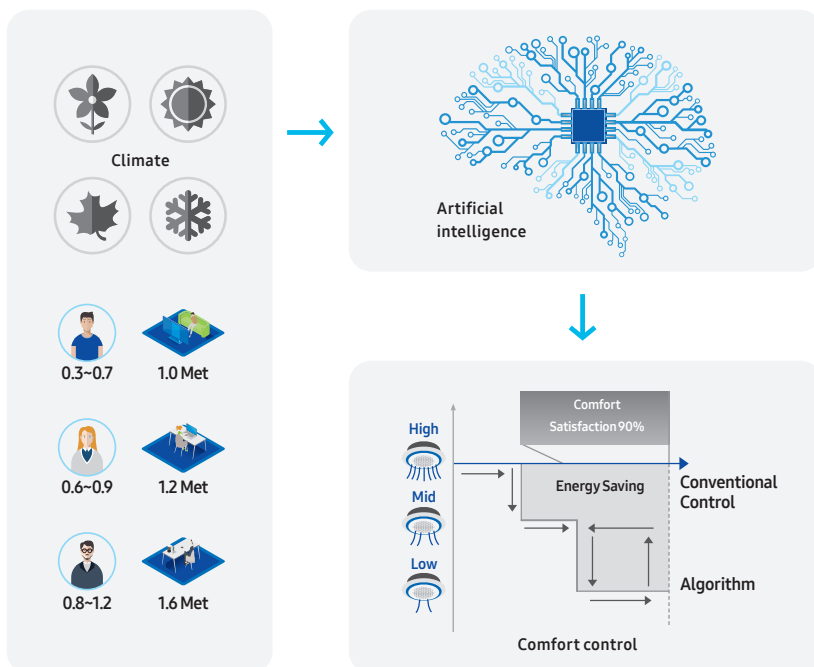

Intelligent energy saving algorithms

- **Data-Based Comfort Control**
Comfort based on user-specific algorithms
- **Learning-Based Control**
Optimised control by artificial intelligence (AI)
- **Occupancy-Based Control**
Lighting, humidity & temperature
- **Inefficient Operation Detection**
Time, space & temperature

Easy and smart operation

- Optimal operation for Samsung VRF (DVM) products
- Intuitive Graphic UI & convenient rules editor for various solutions
- Trends & alarm lookup

Effective energy usage management

- Energy usage analysis
- Energy consumption distribution

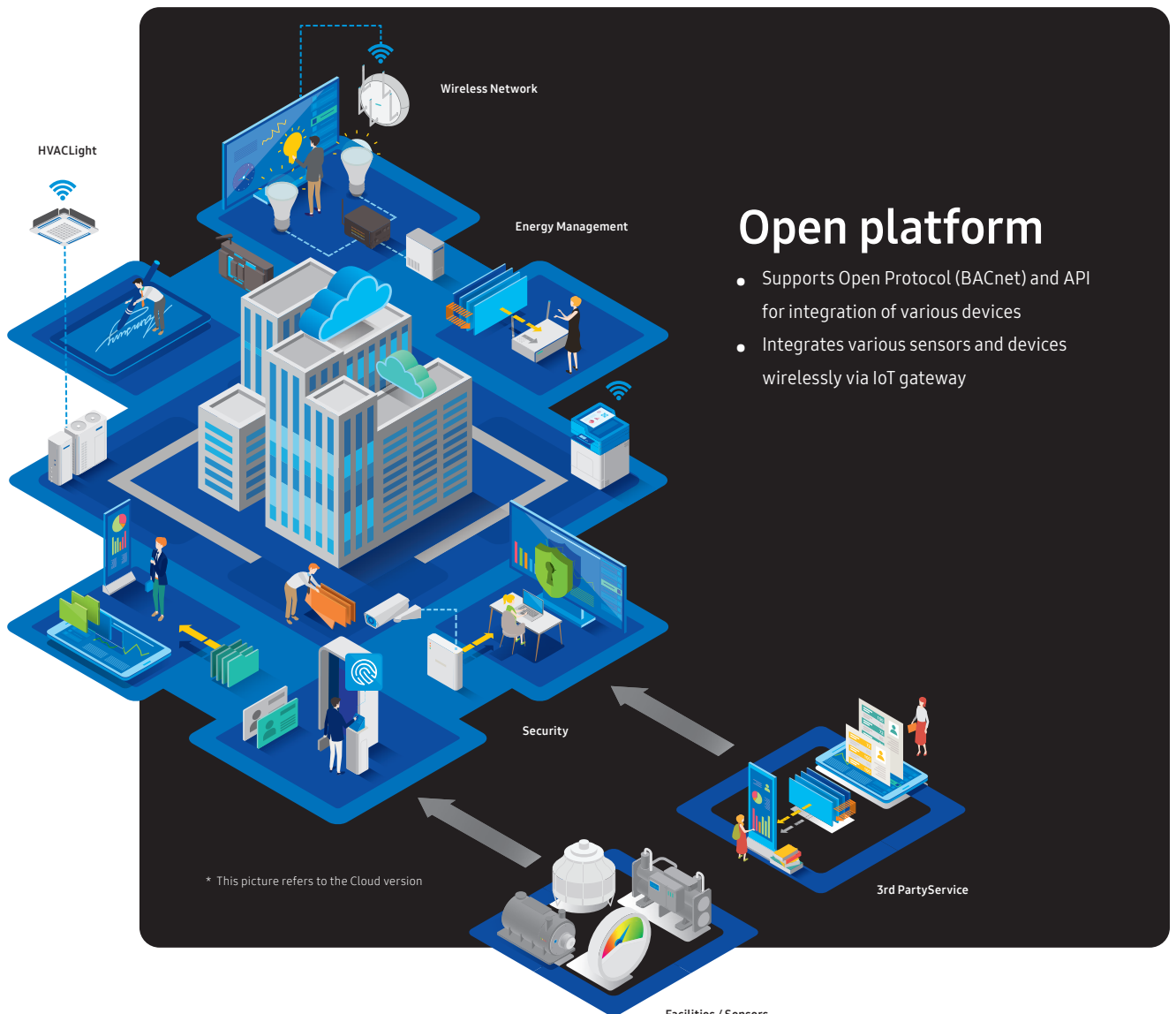
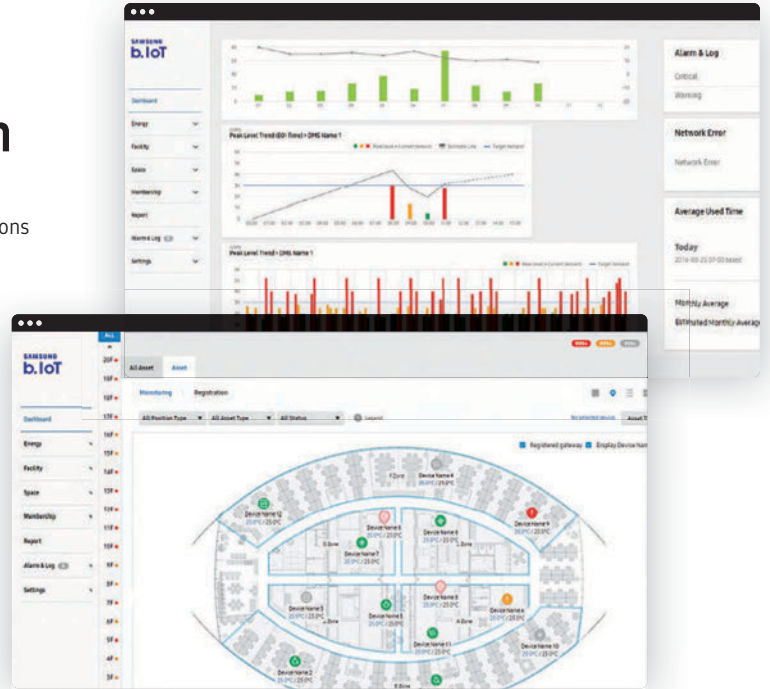

Open platform

- Supports Open Protocol (BACnet) and API for integration of various devices
- Integrates various sensors and devices wirelessly via IoT gateway

Reference Project | Smart Home powered by SmartThings

Woodland Houses Warsaw Poland

A new collaboration with Woodland Houses, located near Warsaw, Poland, offers a unique blend of comfort and modernity. This partnership establishes a residential estate of single-family homes, surrounded by over 200 hectares of forest. Each homeowner can connect through the Samsung's SmartThings app¹ on their mobile device, which serves as a central hub for managing multiple devices, home appliances, and climate control systems.

Samsung has implemented advanced technologies such as the EHS SPLIT R32 ClimateHub Set, Recuperator 350m³h, DVM S Mini 4HP unit, and QMD WindFree™ air conditioners. The all-in-one integrated EHS SPLIT R32 ClimateHub combines heating, cooling, and domestic hot water. The Recuperator 350m³h maintains a fresh airflow by exchanging indoor air with fresh outdoor air, while the DVM S Mini 4HP unit and QMD WindFree™ air conditioners offer climate control with smart features for easy management. These technologies ensure a high standard of living.

The SmartThings app¹ app allows residents to set home routines, enabling automatic adjustments. This project showcases One Samsung, where various Samsung products and technologies work together for a seamless home experience. This integration makes managing home appliances and climate control easy, convenient and enhanced comfort.

¹ Available on Android and iOS devices. Requires iOS 10.0 or later & Android 5.0 or later. A Wi-Fi connection, Samsung account and an optional Wi-Fi Kit (MIM-H04N) are required.



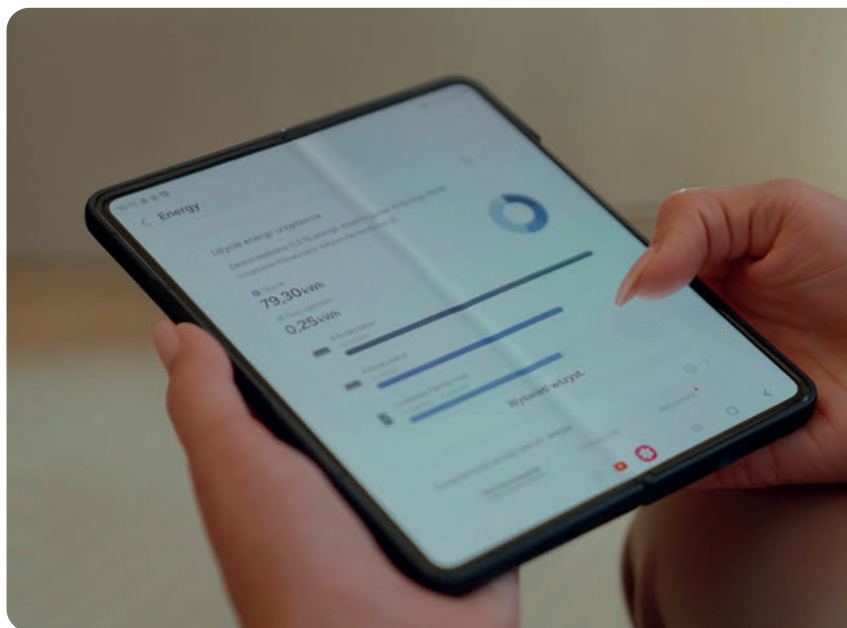

Reference Project

Meadow Herent

The challenge in this 68-apartment sized residential new development project was to find a central heating system that is sustainable, silent, performant and small in size due to limited space. Thanks to our partnership with Samsung we were able to provide our client a cascade construction of high efficiency outdoor units and low temperature hydro units. Now all apartments receive comfortable heating without inconveniences. The low sound pressure and the high available static pressure that allows channeling the outdoor units' air makes this a unique solution.



Jeroen Vercammen

Project manager at Belcotec

Application

Residential New
Development

Samsung products installed



DVM S2 High
efficiency
outdoor units



DVM Hydro Low
Temperature



BACnet





Regulations and standards

Samsung is committed to delivering innovative products and technology that enhance customer experiences while adhering to relevant regulations. Our ongoing research and development efforts span across all phases of product development, from design and production to distribution, use and disposal.









Ecodesign legislation

The Ecodesign Directive is a key regulatory framework aimed at reducing the energy consumption of energy-related products, while encouraging manufacturers to bring the most efficient technologies to market. The Directive applies to a broad range of cooling and heating products, which are categorized into different product groups known as Ecodesign Lots.

Ecodesign Lot 10 has been applicable since 2013 and covers air conditioners with a capacity less or equal than 12 kW, typically used in residential or light commercial applications. Products within this Lot need to meet certain energy efficiency requirements and display an energy label to inform consumers of their performance.

Ecodesign Lot 1 & 2 have been applicable since 2015 and include residential air-to-water heat pumps designed for space heating and domestic hot water, with a capacity up to 400 kW. Products up to 70 kW are required to have an energy label.

Ecodesign Lot 21 has been applicable since 2018. Lot 21 covers larger commercial cooling and heating products with capacities beyond 12kW. Energy labels are not required for these products, but the energy performance data should be made available online.

	LOT 1/2	LOT 10	LOT 21
Applicable since	2015	2013	2018
Scope	A/W heat pumps ≤ 400 kW	Air conditioners ≤ 12 kW	Air conditioners > 12 kW
Energy label required	✓	✓	
Samsung product range	 	  	  
	EHS	RAC FJM CAC	CAC DVM HVM

F-Gas regulation

Since March 2024, the new F-gas Regulation (EU) 2024/573 has taken effect. The F-gas Regulation aims to control the emissions of F-gases used as refrigerants to reduce their impact on global warming. The revision brings new rules, including future bans on certain types of F-gases in products and a quota system to limit the total amount of F-gases placed on the market in Europe. Due to these changes, the industry will invest the coming years in new technologies to use refrigerants with lower Global Warming Potential (GWP) and in some applications use only non-fluorinated refrigerants. Samsung is contributing to the transition towards

lower GWP refrigerants, such as R290, and will continue to invest in alternatives.

From 2025 onwards, the phase-down of F-gas quota will speed up, gradually reducing the amount that can be used in applications in Europe. By 2050, there will be no F-gas quota to place new products on the market, resulting in a complete phase-out of such refrigerants for new installations. In parallel, products bans will start from 2025 and 2027 for split and monoblock heat pumps and air conditioning systems.

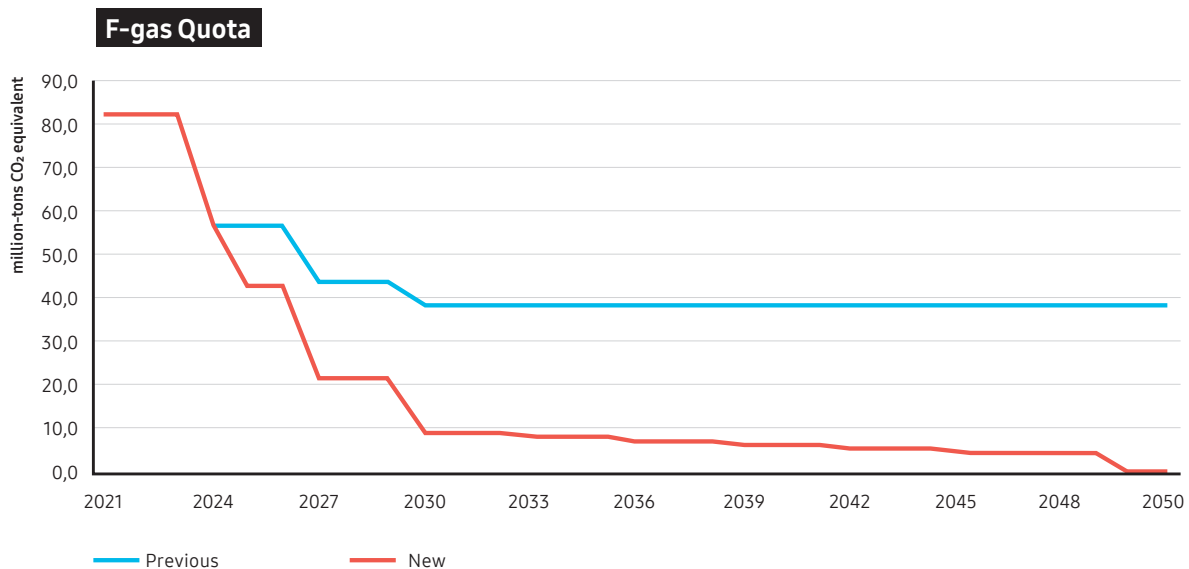

EN378 standard

Effective since 31 May 2017, the European EN378 standard provides guidance for companies who design, install, operate and maintain air conditioners, heat pumps and similar systems that use refrigerants. Based on the access characteristics of occupied spaces into which a refrigerant could leak, and an assessment of the refrigerant's toxicity and flammability, refrigerant charge limits are set and safety measures are prescribed to mitigate risk in the possible event of a refrigerant leakage.

Access categories range from general access areas, such as hotels, restaurants and shopping areas, to more restricted supervised and authorised areas.

The location of refrigerant systems follows a classification of four classes, where VRF systems are typically defined as Class II, either located in a machine room or in the open air. Subject to the available ventilation in rooms, additional measures may be needed such as mechanical ventilation or detectors.

Samsung offers specialist support to professionals in the design of cooling and heating installations. Please contact your Samsung representative to enquire about support in aligning your project design with the requirements of the EN378 standard.



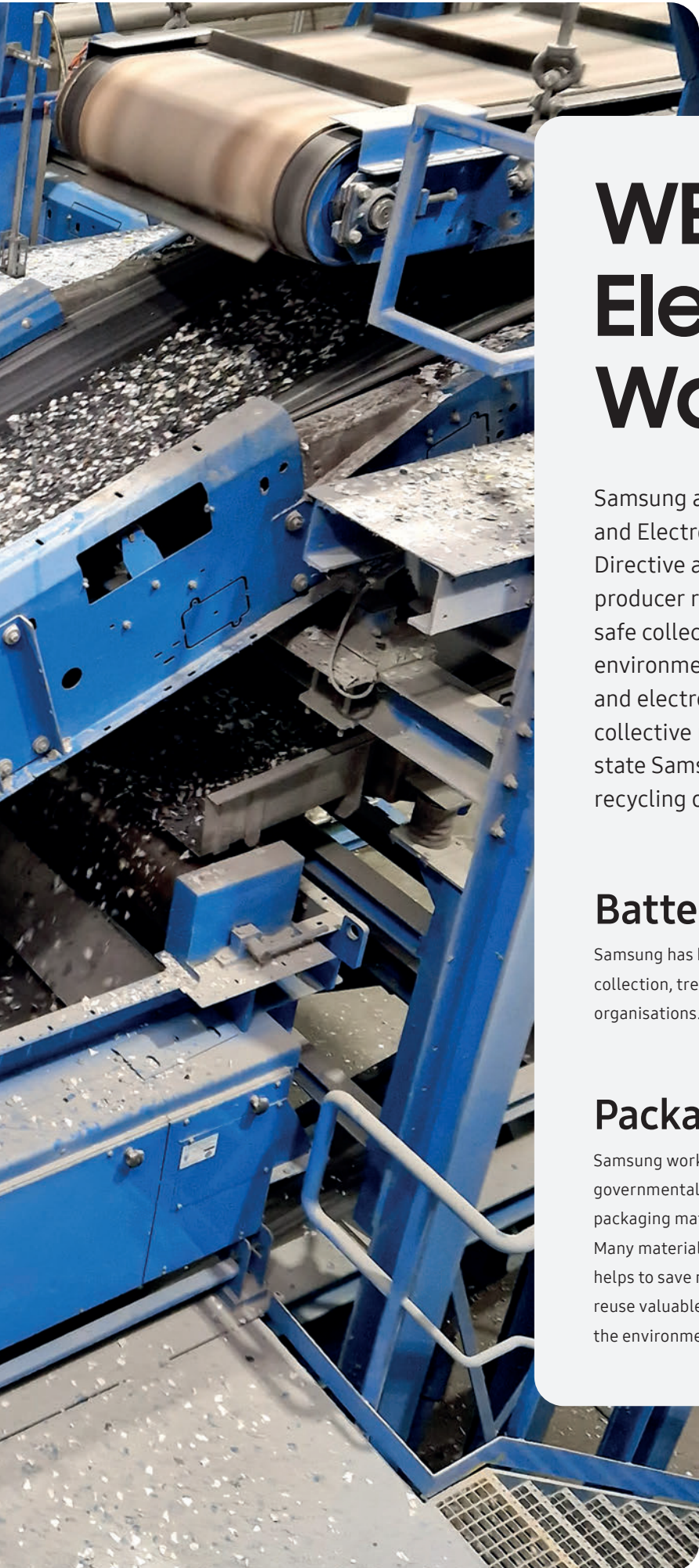

WEEE: Electronic Waste

Samsung adheres to the WEEE (Waste Electrical and Electronic Equipment) Directive. This Directive applies to the principles of extended producer responsibility. It stipulates the safe collection, treatment, recycling and environmentally sound disposal of all electrical and electronic equipment. By working with collective recycling schemes in each EU member state Samsung co-finances the take-back and recycling of electronic products.

Batteries

Samsung has been giving new life to used batteries by funding collection, treatment and recycling by local battery recycling organisations.

Packaging

Samsung works together with recycling schemes and governmental organisations to collect, separate and recycle all packaging materials at various points in the distribution chain. Many materials can be recycled into new products and recycling helps to save natural resources. Recycling packaging helps to reuse valuable raw materials and to reduce the overall impact on the environment.

Certifications

Intertek

Intertek is a leading Total Quality Assurance provider to industries worldwide verifying air quality. To deliver credibility, Intertek maintains extensive global accreditations and recognitions for testing and certification services. Working with Intertek helps showcase and maintain products' safety and performance attributes. Intertek's expertise in regulatory standards and certifications keeps you ahead of changes and challenges.

Intertek offers certification programmes that achieve market entry into a variety of global destinations, programmes for a more eco-friendly environment and also programmes to verify social

accountability compliance for both manufacturers and suppliers. Samsung's Tri-Care Filter, Air Purification Panels for WindFree™ 1-Way Cassette, WindFree™ 4-Way Cassette and 360 Cassette have been verified by Intertek.

To check the ongoing validity of the Intertek certified products from Samsung, please visit: www.intertek.com



Eurovent

Eurovent is globally known for its quality mark 'Eurovent Certified Performance' which certifies performance ratings of air-conditioning and refrigeration products according to European and international standards. The 'Eurovent Certified Performance' mark indicates that the prescribed quality requirement has been fulfilled and should not require the need to be proven after the customer's decision and after the manufacturer's production process.

Eurovent is an accredited third-party certification body. It builds customer confidence by leveling the competitive playing field for all manufacturers and by increasing the integrity and accuracy of the industrial performance ratings. Thus providing

trustworthy services to the entire ecosystem. Samsung air conditioning products ranging from the Single Split (RAC), Multi Split (FJM), Commercial Split (CAC), Variable Refrigerant Flow (VRF) and EHS line-up in the 'Air-to-Water' (A2W) heat pump category are all Eurovent certified.

To check the ongoing validity of the Eurovent certified products from Samsung, please visit: www.eurovent-certification.com





VRF

Complete and cost-effective climate control with VRF









Variable Refrigerant Flow (VRF) systems – or Digital Variable Multi (DVM) systems – provide reliable, efficient, comfortable, and flexible climate control for large commercial applications. They are easy to install and offer capacities of up to 98 HP.

A VRF system connects one outdoor unit to up to 64 indoor units via refrigerant piping for heating, air-conditioning, ventilation, and heat recovery in individual zones. Capacity is modulated based on the requirements of the zones, which saves energy and improves climate comfort.





Line-up outdoor

Model	Image	Capacity (HP)													
		4	5	6	8	10	12	14	16	18	20	22	24	26	30
Heat Pump															
DVM S Mini Heat Pump		•	•	•											
DVM S Heat Pump		•	•		•	•	•								
DVM S2 Essential Heat Pump (2-Pipe)							•	•	•	•	•				
DVM S2 Standard Heat Pump (2-Pipe)					•	•	•	•	•	•	•	•	•	•	•
DVM S2 High Efficiency Heat Pump (2-Pipe)					•	•	•	•	•	•	•	•	•	•	•
Heat Recovery															
DVM S Heat Recovery (With Heat Recovery Changer Kit)		•	•	•											
DVM S2 High Efficiency Heat Recovery (3-Pipe)					•	•	•	•	•	•	•	•	•	•	•
Water to Air/Water															
DVM S Water					•	•	•				•				•







Selection guide

Heat pump



Model	DVM S Mini		DVM S		DVM S2 Essential	DVM S2 Standard	DVM S2 High Efficiency
	AM***DXMDKG/EU AM***DXMDNG/EU	AM***BXMDKH/EU AM***BXMDGH/EU	AM***BXMDKH/EU AM***BXMDGH/EU	AM***BXMDKH/EU AM***BXMDGH/EU	AM***AXVDGH/EU	AM***AXVAGH/EU	AM***AXVGGH/EU
Type							
Heat Pump	•	•	•	•	•	•	•
Heat Recovery							
Capacity range	4-6 HP	4-8 HP	8-12 HP	10-40 HP	8-98 HP	8-98 HP	
Connectability							
WindFree™ Cassette	•	•	•	•	•	•	•
360 Cassette	•	•	•	•	•	•	•
LSP Duct	•	•	•	•	•	•	•
MSP Duct	•	•	•	•	•	•	•
HSP Duct	•	•	•	•	•	•	•
ERV Plus/OAP Duct		•	•	•	•	•	•
Wall-Mounted	•	•	•	•	•	•	•
Ceiling/Concealed/Floor-Standing		•	•	•	•	•	•
Hydro unit HE/HT		•	•	•	•	•	•
MCU Kit		•	•	•	•	•	•
AHU Kit		•	•	•	•	•	•
Features							
Refrigerant check mode	•	•	•	•	•	•	•
Simultaneous cooling and heating							
7-Segment display	•	•	•	•	•	•	•
Four-Way direction piping connection	•	•	•	•	•	•	•
Advanced Flash Injection™					•	•	•
Cooling @ 50°C					•	•	•
Heating @ -25°C ²			•	•	•	•	•
Max. External Static Pressure 110Pa ²					•	•	•
Improved fan diffuser					•	•	•
Reduced air flow noise					•	•	•
Leak detection (pump down function)	•	•	•	•	•	•	•
Night silent mode	•	•	•	•	•	•	•
Variable Refrigerant Temperature	•	•	•	•	•	•	•
Inverter scroll compressor			•	•	•	•	•
Twin BLDC rotary compressor	•	•	•	•	•	•	•
DC fan motor	•	•	•	•	•	•	•
Multi-serration Fan ²					•	•	•
Active AI Pressure Control	•	•	•	•	•	•	•
Active AI Defrost					•	•	•
Active AI Refrigerant Analysis	•	•	•	•	•	•	•
On-device Inverter Checker™					•	•	•
Durafin™ Ultra Heat Exchanger Fin	•	•	•	•	•	•	•
Slimmer Liquid Line ³					•	•	•
Refrigerant type	R32	R410A	R410A	R410A	R410A	R410A	R410A
Smart Protection Technology							
Adaptive Sine Wave	•	•	•	•	•	•	•
Refrigerant cooled PCB					•	•	•
Resonance Avoidance Technology	•	•	•	•	•	•	•

¹ Can be connected as a 2-pipe system.
² Model specific.
³ Optional.

Selection guide

Cassette



Model	WindFree™ 1-Way Cassette	WindFree™ 4-Way Cassette	360 Cassette
Airflow			
WindFree™ Cooling	•	•	
360 Degree Air Supply			•
Air Purification			
SPi Kit		Optional	Optional
Air Filter	•	•	•
Functions			
Compatible with Samsung SmartThings	•	•	•
Compatible with Wi-Fi Kit	•	•	•
Humidity Sensor	•	•	•
MDS (Motion Detect Sensor)		Optional	Optional
Automatic ESP Setting			
Quiet Mode	•	•	
Controls			
Wireless remote controller included			
Others			
EEV included	•	•	•
Built-In Drain Pump	•	•	•

Others



Model	Console	Floor/Ceiling	Big Ceiling	Concealed Floor-Standing	Packaged Floor-Standing
Airflow					
WindFree™ Cooling					
360 Degree Air Supply					
Air Purification					
SPi Ioniser			Optional		
Air Filter	•	•	•	•	•
Functions					
Compatible with Samsung SmartThings	•	•	•	•	•
Compatible with Wi-Fi Kit	•	•	•	•	•
Humidity Sensor					
MDS (Motion Detect Sensor)					
Automatic ESP Setting					
Quiet Mode				•	
Controls					
Wireless remote controller included	•				
Others					
EEV included	•		•	•	•
Built-In Drain Pump					

Duct



Model	LSP Duct	MSP Duct	HSP Duct
Airflow			
WindFree™ Cooling			
360 Degree Air Supply			
Air Purification			
SPI Kit		Optional	Model-specific
Air Filter	•	•	•
Functions			
Compatible with Samsung SmartThings	•	•	•
Compatible with Wi-Fi Kit	•	•	•
Humidity Sensor			
MDS (Motion Detect Sensor)			
Automatic ESP Setting		•	Model-specific
Quiet Mode			
Controls			
Wireless remote controller included			
Others			
EEV included	•	•	•
Built-In Drain Pump	Model-specific	•	Model-specific



Model	Hydro Unit HE	Hydro Unit HT
Airflow		
WindFree™ Cooling		
360 Degree Air Supply		
Air Purification		
SPI Ioniser		
Air Filter		
Functions		
Compatible with Samsung SmartThings		
Compatible with Wi-Fi Kit		
Humidity Sensor		
MDS (Motion Detect Sensor)		
Automatic ESP Setting		
Quiet Mode		
Controls		
Wireless remote controller included		
Others		
EEV included	•	•
Built-In Drain Pump		

Wall-mounted



Model	WindFree™ Deluxe	Max Wall-Mounted
Airflow		
WindFree™ Cooling	•	
360 Degree Air Supply		
Air Purification		
SPI Ioniser		
Air Filter	•	•
Functions		
Compatible with Samsung SmartThings	•	•
Compatible with Wi-Fi Kit	•	•
Humidity Sensor		
MDS (Motion Detect Sensor)		
Automatic ESP Setting		
Quiet Mode		
Controls		
Wireless remote controller included	•	
Others		
EEV included	Model-specific ¹	•

¹ EEV kit is necessary for all Indoor Units which do not have EEV kit included, please order EEV Kit separately.





Nomenclature

Indoor units

AM	056	D	N	4	D	K	G
1	2	3	4	5	6	7	8

1	Classification	AM	VRF (DVM)
		AN	Ventilation (ERV)
2	Capacity	x 1/10 kW (3 digits)	
3	Version	F	2013
		H	2014
		J	2015
		K	2016
		M	2017
		N	2018
		R	2019
		T	2020
		A	2021
		B	2022
		C	2023
4	Product Type	N	Indoor Unit (NASA)
		S	ERV
5	Product Notation	1	WindFree™ 1-Way Cassette
		4	360 Cassette & WindFree™ 4-Way Cassette
		6	360 Cassette Universal
		N	WindFree™ 4-Way 600 x 600 Cassette
		L	Low Static Pressure Duct (Slim Duct)
		M	Medium Static Pressure Duct
		H	High Static Pressure Duct
		E	Outdoor Air Processing Duct
		C	Ceiling
		J	Console
		F	Floor-Standing
		P	Packaged Floor-Standing
		A	AR5000 Wall-Mounted (EEV excluded)
		V	AR5000 Wall-Mounted (EEV included)
		6	Feature
K	ERV (Plus)		
F	Flagship		
P	Premium		
7	Voltage Rating	D	Deluxe
		S	Standard
		E	1Φ, 220–240 V, 50 Hz
8	Mode	K	1Φ, 220–240 V, 50/60 Hz
		G	3Φ, 220–240 V, 50 Hz
		G	Heat Pump (R32)
		H	Heat Pump (R410A)
		B	Heat Pump (R134A)
		N	ERV

Nomenclature

Outdoor units

AM	040	D	X	M	D	K	G
1	2	3	4	5	6	7	8

1	Classification	AM	VRF (DVM)
2	Capacity	x 1/10 HP (3 digits)	
3	Version	K	2016
		M	2017
		N	2018
		R	2019
		T	2020
		A	2021
		B	2022
		D	2024
4	Product Type	X	Outdoor Unit
5	Product Notation	V	DVM S Essential/Standard/High Efficiency
		W	DVM S Water
		M	DVM S / DVM S Mini
6	Feature	A	Standard + General Temperature + Module
		H	High EER + Low Temperature + Module
		G	High EER + General Temperature + Module
		D,W	Standard + General Temperature + Non-Module
7	Voltage Rating	E	1Φ, 220-240 V, 50 Hz
		K	1Φ, 220-240 V, 50/60 Hz
		G	3Φ, 380-415 V, 50 Hz
		N	3Φ, 380-415 V, 50/60 Hz
8	Mode	G	Heat Pump R32
		H	Heat Pump R410A
		R	Heat Recovery

DVM S Mini

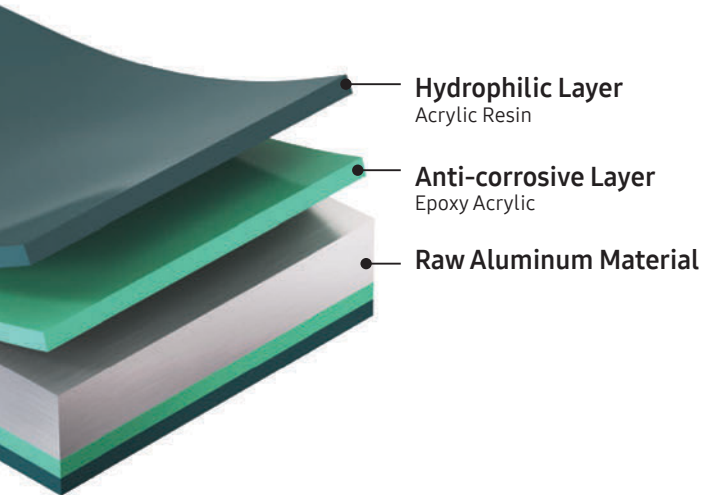

Durafin™ Ultra Technology

The Durafin™ Ultra¹ technology shields the heat exchanger with a dual-layer defence: an epoxy acrylic anti-corrosive layer coupled with a hydrophilic acrylic resin layer. This repels water and prevents corrosion from forming on the heat exchanger, to maintain optimal performance and efficiency.

Silent Mode

Combined with specially shaped fans and compact, unimposing design it creates a more pleasant residential and working environment. The Silent Mode function² creates a restful environment with a reduced noise level.

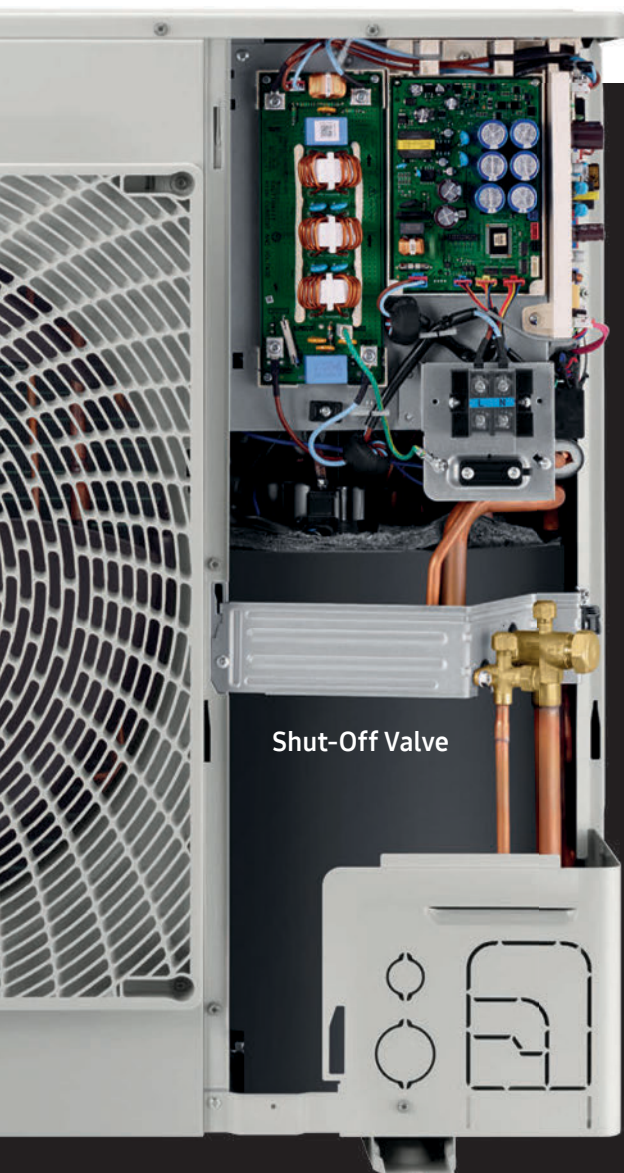

Meeting Safety Requirements

The safety devices integrated in DVM S Mini R32 guarantee maximum flexibility with the IEC 60335-2-40 standard. The outdoor unit is equipped with a shut-off valve and battery pack, while the indoor units connected have a built-in R32 refrigerant leak detect sensor. The remote controller³ has an audible and visible alarm system to alert users in the event of R32 leakage.



VIDEO

**DVM S Mini
Emergency**

Samsung b.IoT Lite ready

Samsung b.IoT (building Internet of Things) is a building management solution that can efficiently manage and help to save energy. It's an open platform with expandability and compatibility options that enable integrated control of the facility's major systems. The synergy between the DVM S Mini R32 and b.IoT Lite paves the way for streamlined installations, optimised energy management, and efficient operations, all while maintaining comprehensive oversight of integrated systems.

Smart Control

The DVM S Mini R32 enhances the user experience with Wi-Fi-enabled control, thanks to the factory-integrated Single Wi-Fi kit (MIM-H14EN). This allows for effortless management through the intuitive SmartThings App⁴ and empowers users to monitor energy usage and adjust settings on-the-go, ensuring a harmonious balance between comfort and energy usage⁵.

Active AI

The DVM S Mini R32 is equipped with multiple Active AI features designed to enhance efficiency and user comfort:

AI Refrigerant Analysis uses Deep Learning technology to collect and analyse various operational data in real time, proactively alerting users if the refrigerant level is too low, ensuring optimal performance.

Active AI High Pressure Control adjusts high pressure based on piping length and elevation differences, using an AI learning algorithm to reduce unnecessary high pressure, thereby improving power consumption and efficiency.

Active AI Low Pressure Control⁶ learns cooling operation patterns to quickly reach the target low pressure, saving energy by preventing over-cooling and enhancing comfort by speeding up the cooling process.

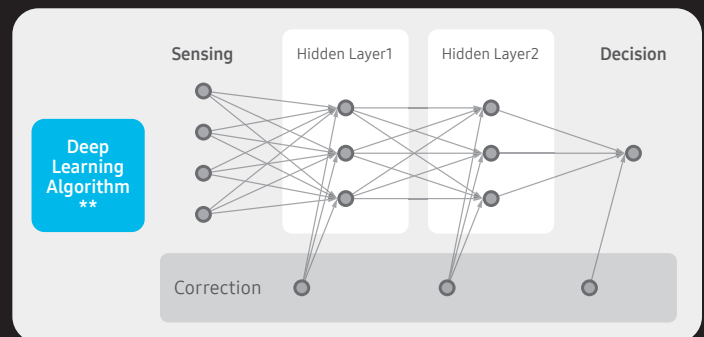

VIDEO
DVM S Mini
High Pressure
Control



VIDEO
DVM S Mini
Low Pressure
Control

¹ Only available on certain models. Based on internal testing, verified by TÜV Rheinland, in accordance with ISO 9227, ISO 14993 and ISO 21207 using specimens from the heat exchanger of a DVM outdoor unit. For more details, please contact Samsung's technical professionals. Based on testing by a third-party lab, applying the actual pressure of refrigerant for 1 minute, after a Salt Spray Test (SST) of over 10,000 hours.

² Silent mode can be activated by the installer depending on the model code during the installation/service stage. Reduction of sound levels could reduce heat pump capacity. Depending on ambient temperature.

³ Only available for model codes: MWR-WG01JN and MWR-WG01KN.

⁴ Samsung SmartThings application account and internet connection are required. Requires iOS 10.0 or later & Android 5.0 or later.

⁵ Available in selected models only.

⁶ Based on internal testing of the cooling operation, with the temperature set at 22°C and using Auto mode for 4 hours, at a room temperature of 33°C and an external temperature of 35°C. The tested model was an AM060DXMDKG/EU connected to AM140DN4DKG/EU indoor unit with 25m of piping. The elapsed times were measured when the room temperature reached 25°C.

Specifications

DVM S Mini R32

- Horizontal discharge and rear suction one propeller BLDC Inverter fan (4~6 HP).
- Safety devices integrated (standard IEC 60335-2-40):
 - shut-off valve and battery pack (outdoor unit)
 - R32 refrigerant leak detector sensor (indoor unit)
 - audible & visible alarm system (wired control)
- Active AI Pressure Control.
- Active AI Refrigerant analysis.
- Durafin™ Ultra Heat Exchanger Fin.
- Night Silent Mode available.
- Eurovent certified and ErP (Ecodesign) compliant.
- Four-Way direction piping connection.
- Indoor Cassettes with Wi-Fi embedded.
- b.IoT Lite ready.



Model			AM040DXMDKG/EU	AM050DXMDKG/EU	AM060DXMDKG/EU
Power Supply			Φ, #, V, Hz		
			1Φ, 2, 220-240 V, 50/60 Hz	1Φ, 2, 220-240 V, 50/60 Hz	1Φ, 2, 220-240 V, 50/60 Hz
Performance					
HP		HP	4	5	6
Capacity	Cooling	kW	12,1	14	15,5
	Heating	kW	12,1	14	15,5
Maximum number of connectable indoor units			ea	8	9
Total capacity of the connected indoor units	Min.	kW	6	7	7,8
	Max.	kW	15,7	18,2	20,2
Power					
Power Input	Cooling	kW	3,73	4,83	5,62
	Heating (max)	kW	2.75 (3.55)	3.37 (4.10)	3.78 (5.00)
Current Input	Cooling	A	17,1	22,1	25,7
	Heating (max)	A	12.6 (16.2)	15.4 (18.8)	17.3 (22.9)
Current	MCA	A	22	24	32
	MFA	A	25	32	40
Energy Efficiency 1					
EER (Nominal Cooling)		W/W	3,24	2,9	2,76
COP (Nominal Heating)		W/W	4,4	4,15	4,1
SEER (Cassette)		W/W	8.50/7.90	8.20/7.40	8.00/7.20
SCOP (Cassette)		W/W	5.10/4.80	5.10/4.70	5.10/4,60
η _{s,c} % - η _{s,h} % Cassette		%	337%-201%	325%-201%	317%-201%
η _{s,c} % - η _{s,h} % Ducted		%	313%-189%	293%-185%	285%-181%
Compressor					
Type		-	Twin BLDC Rotary	Twin BLDC Rotary	Twin BLDC Rotary
Output		-	4,35	4,35	4,35
Oil	Type	-	POE	POE	POE
	Initial Charge	cc	1,5	1,5	1,5
Fan					
Type & Discharge direction		-	Propeller	Propeller	Propeller
		-	Horizontal	Horizontal	Horizontal
Number of Fans		ea	1	1	1
Airflow Rate		m ³ /min	69	77	80
Fan Motor					
Model		-	BLDC Motor	BLDC Motor	BLDC Motor
Output x n		W	122 x 1	122 x 1	122 x 1
Piping Connection					
Liquid Pipe		Ø, mm	9.52	9.52	9.52
		Ø, inch	3/8	3/8	3/8
Gas Pipe		Ø, mm	15,88	15,88	19,05
		Ø, inch	5/8	5/8	3/4
Piping length (ODU-IDU) ³	Max. (Equiv.)	m	80 (100)	80 (100)	80 (100)
Piping length (1st Branch - IDU) ³	Max.	m	40	40	40
Total piping length (System)	Max.	m	150	150	150
Level Difference (Outdoor in highest position)	Max.	m	30	30	30
Level Difference (Indoor in highest position)	Max.	m	25	25	25
Level Difference (IDU-IDU) ³	Max.	m	15	15	15
Wiring Connection					
Communication	Min.	mm ²	0.75	0.75	0.75
	Remark	-	F1, F2	F1, F2	F1, F2
Refrigerant					
Type		-	R32(Fluorinated greenhouse gas, GWP=675)		
Factory Charging		kg / tCO ₂ e	2.20/1.49	2.20/1.49	2.20/1.49
Sound²					
Sound Pressure	Cooling	dB(A)	55	57	58
	Heating	dB(A)	57	59	60
Sound Power	Cooling	dB(A)	68	70	71
	Heating	dB(A)	72	74	76
External Dimensions					
Net Weight		kg	90	90	90
Net Dimensions (W x H x D)		mm	940 x 840 x 460	940 x 840 x 460	940 x 840 x 460
Operating Temperature					
Cooling		°C	-5.0-48.0	-5.0-48.0	-5.0-48.0
Heating		°C	-25.0-26.0	-25.0-26.0	-25.0-26.0



AM040DXMDNG/EU	AM050DXMDNG/EU	AM060DXMDNG/EU
3Φ, 4, 380-415 V, 50/60 Hz	3Φ, 4, 380-415 V, 50/60 Hz	3Φ, 4, 380-415 V, 50/60 Hz
4	5	6
12,1	14	15,5
12,1	14	15,5
8	9	10
6	7	7,8
15,7	18,2	20,2
3,73	4,83	5,62
2.75 (3.55)	3.37 (4.10)	3.78 (5.00)
5,9	7,6	8,8
4.3 (5.6)	5.3 (6.4)	5.9 (7.8)
16,1	16,1	16,1
20	20	20
3,24	2,9	2,76
4,4	4,15	4,1
8.50/7.90	8.20/7.40	8.00/7.20
5.10/4.80	5.10/4.70	5.10/4.60
337%-201%	325%-201%	317%-201%
313%-189%	293%-185%	285%-181%
Twin BLDC Rotary	Twin BLDC Rotary	Twin BLDC Rotary
4,35	4,35	4,35
POE	POE	POE
1,5	1,5	1,5
Propeller	Propeller	Propeller
Horizontal	Horizontal	Horizontal
1	1	1
68	77	80
BLDC Motor	BLDC Motor	BLDC Motor
122 x 1	122 x 1	122 x 1
9.52	9.52	9.52
3/8	3/8	3/8
15,88	15,88	19.05
5/8	5/8	3/4
80 (100)	80 (100)	80 (100)
40	40	40
150	150	150
30	30	30
25	25	25
15	15	15
0.75	0.75	0.75
F1, F2	F1, F2	F1, F2
R32(Fluorinated greenhouse gas, GWP=675)		
2.20/1.49	2.20/1.49	2.20/1.49
55	57	58
57	59	60
68	70	71
72	74	76
90	90	90
940 x 840 x 460	940 x 840 x 460	940 x 840 x 460
-5.0-48.0	-5.0-48.0	-5.0-48.0
-25.0-26.0	-25.0-26.0	-25.0-26.0

- ¹ Performances are based on the following test conditions:
- Cooling: Indoor temperature: 27°C DB, 19°C WB, Outdoor temperature: 35°C DB, 24°C WB
 - Heating: Indoor temperature: 20°C DB, 15°C WB, Outdoor temperature: 7°C DB, 6°C WB
 - Equivalent refrigerant piping: 7.5 m, Level differences: 0 m

² Sound pressure level is obtained in an anechoic room. Sound pressure level is a relative value, depending on the distance and acoustic environment. Sound pressure level may differ according to operating conditions. Sound power level is an absolute value that a sound source generates. Sound Power: ODU and IDU operation mode is "Cooling" and hydro unit is "Heating".

³ ODU: Outdoor Unit, IDU: Indoor Unit



DVM S



High capacity in a compact design

DVM S combines a high capacity up to 12 HP. It is one of the most compact air conditioner units in its class today, making the DVM S very easy and economical to install and operate without compromising on performance. It makes good use of valuable space with a compact design. With a height of just 1210 mm and only 0.318 m², its overall volume is 5% less than competing models¹. It makes it a convenient space-saving option in offices and can be installed easily in a wide range of locations.

¹ Based on internal testing. Height comparison in 6HP models: Samsung DVM S = 1210 mm vs. Model of a competing brand = 1380 mm.

Silent mode

By producing less noise than conventional Samsung models, the DVM S imposes fewer distractions on residential and working environments. Its compact, unimposing design and specially shaped fan blades help reduce sound levels in 3 steps, creating a more pleasant environment.

Additionally, its quiet operation during the night creates a restful environment with a reduced noise level of 3–7 dB(A)¹.

¹ Based on internal testing comparing silent mode with regular operating mode. Sound pressure level is obtained in an anechoic room. Sound pressure level is a relative value, depending on the distance and acoustic environment. Sound pressure level may differ depending on operation conditions. Silent mode is available by option setting.

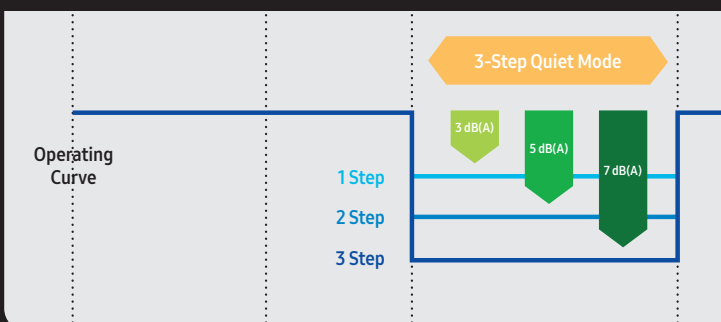
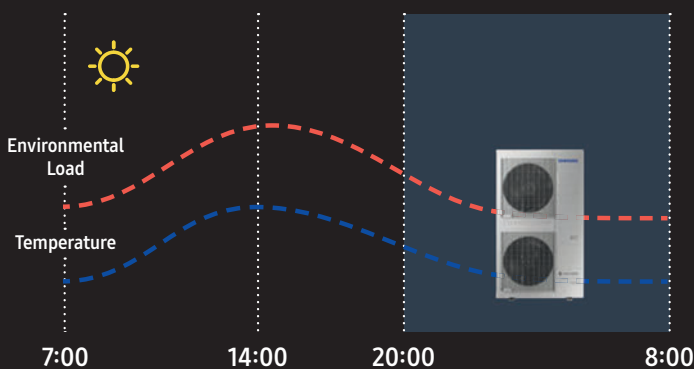



Specifications

DVM S Heat Pump (R410A)

- Horizontal discharge and rear suction by means of one (4~5 HP) or two (8~14 HP) propeller BLDC Inverter fan(s).
- Each module houses one compressor: Twin BLDC Rotatory (4~8 HP) or Inverter Scroll with Flash Injection technology (10~14 HP).
- Compressor micro frequency control with 0.01 Hz step.
- Night Silent Mode available.
- Eurovent certified and ErP (Ecodesign) compliant.
- Four-Way direction piping connection.



Model			AM040BXMDHEH/EU	AM050BXMDHEH/EU	AM080BXMDGH/EU
Power Supply		Φ, #, V, Hz	1Φ, 2, 220~240 V, 50 Hz	1Φ, 2, 220~240 V, 50 Hz	3Φ, 4, 380~415 V, 50 Hz
Performance					
HP		HP	4	5	8
Capacity	Cooling	kW	12.1	14	22.4
	Heating	kW	12.1	14	22.4
Maximum number of connectable indoor units		ea	6	8	13
Total capacity of the connected indoor units	Min.	kW	5.6	7	11.2
	Max.	kW	15.7	18.2	29.1
Power					
Power Input	Cooling	kW	3.9	5.19	10.98
	Heating	kW	3.23	4.12	6.4
Current Input	Cooling	A	17.8	23.8	17.2
	Heating	A	14.8	18.9	10
Current	Minimum SSC value	MVA	-	-	3.4
	MCA	A	24	27	18.4
	MFA	A	32	40	25
Energy Efficiency¹					
EER (Nominal Cooling)		W/W	3.1	2.7	2.04
COP (Nominal Heating)		W/W	3.75	3.4	3.5
SEER (Cassette)		W/W	7.6	7.35	6
SCOP (Cassette)		W/W	4.2	4.4	4.25
Compressor					
Type		-	Twin BLDC Rotary	Twin BLDC Rotary	Twin BLDC Rotary
Output		kW × n	4.04 × 1	4.04 × 1	4.78 × 1
Oil	Type	-	PVE	PVE	PVE
	Initial Charge	cc	1,700	1,700	1,700
Fan					
Type & Discharge direction		-	Propeller	Propeller	Propeller
		-	Horizontal	Horizontal	Horizontal
Number of Fans		ea	1	1	2
Airflow Rate		m ³ /min	64	70	135
External Static Pressure	Max.	mmAq	3	3	3
		Pa	29.4	29.4	29.4
Fan Motor					
Model		-	BLDC Motor	BLDC Motor	BLDC Motor
Output x n		W	125 x 1	139 x 1	139 x 2
Piping Connection					
Liquid Pipe		Ø, mm	9.52	9.52	9.52
		Ø, inch	3/8	3/8	3/8
Gas Pipe		Ø, mm	15.88	15.88	19.05
		Ø, inch	5/8	5/8	3/4
Piping length (ODU-IDU) ³	Max. (Equiv.)	m	50 (65)	50 (65)	100 (130)
Piping length (1st Branch - IDU) ³	Max.	m	40	40	40
Total piping length (System)		Max.	150	150	300
Level Difference (Outdoor in highest position)		Max.	30	30	30
Level Difference (Indoor in highest position)		Max.	25	25	30
Level Difference (IDU-IDU) ³		Max.	15	15	30
Wiring Connection					
Communication	Min.	mm ²	0.75	0.75	0.75
	Remark	-	F1, F2	F1, F2	F1, F2
Refrigerant					
Type			R410A (Fluorinated greenhouse gas, GWP=2,088)		
Factory Charging		kg / tCO ₂ e	2.00/4.18	2.50/5.22	3.70/7.73
Sound²					
Sound Pressure	Cooling	dB(A)	53	56	58
	Heating	dB(A)	56	58	59
Sound Power		dB(A)	70	73	73
External Dimensions					
Net Weight		kg	79	84	115
Net Dimensions (W x H x D)		mm	940 x 998 x 330	940 x 998 x 330	940 x 1,420 x 330
Operating Temperature					
Cooling		°C	-5.0~48.0	-5.0~48.0	-5.0~48.0
Heating		°C	-20.0~24.0	-20.0~24.0	-20.0~24.0



AM080BXMWGH/EU	AM100BXMWGH/EU	AM120BXMWGH/EU
3Φ, 4, 380-415 V, 50 Hz	3Φ, 4, 380-415 V, 50 Hz	3Φ, 4, 380-415 V, 50 Hz
8	10	12
22.4	28	33.6
22.4	28	33.6
13	18	21
11.2	14	16.8
29.1	36.4	43.6
9.96	12.73	14.3
5.89	7.78	9.21
15.6	20	22.4
9.2	12.2	14.4
3.4	4.6	5.1
18	21.5	23.5
25	30	30
2.25	2.2	2.35
3.8	3.6	3.65
6.3	6.4	6.5
4.25	4.15	4.5
Scroll Inverter	Scroll Inverter	Scroll Inverter
5.18 x 1	6.39 x 1	6.39 x 1
PVE	PVE	PVE
1,100	1,100	1,100
Propeller	Propeller	Propeller
Horizontal	Horizontal	Horizontal
2	2	2
135	165	166
3	3	3
29.4	29.4	29.4
BLDC Motor	BLDC Motor	BLDC Motor
139 x 2	244 x 2	244 x 2
9.52	9.52	12.70
3/8	3/8	1/2
19.05	22.22	28.58
3/4	7/8	11/8
100 (130)	160 (185)	160 (185)
40	40	40
300	300	300
50	50	50
40	40	40
50	50	50
0.75	0.75	0.75
F1, F2	F1, F2	F1, F2
R410A(Fluorinated greenhouse gas, GWP=2,088)		
3.70/7.73	4.30/8.98	4.80/10.02
58	58	60
59	64	64
73	74	76
135	155	162
940 x 1,420 x 330	940 x 1,630 x 460	940 x 1,630 x 460
-5.0-48.0	-5.0-52.0	-5.0-52.0
-20.0-24.0	-25.0-24.0	-25.0-24.0

¹ Performances are based on the following test conditions:
 - Cooling: Indoor temperature: 27°C DB, 19°C WB, Outdoor temperature: 35°C DB, 24°C WB
 - Heating: Indoor temperature: 20°C DB, 15°C WB, Outdoor temperature: 7°C DB, 6°C WB
 - Equivalent refrigerant piping: 7.5 m, Level differences: 0 m

² Sound pressure level is obtained in an anechoic room. Sound pressure level is a relative value, depending on the distance and acoustic environment. Sound pressure level may differ according to operating conditions. Sound power level is an absolute value that a sound source generates. Sound Power: ODU and IDU operation mode is "Cooling" and hydro unit is "Heating".

³ ODU: Outdoor Unit, IDU: Indoor Unit



DVM S2

Higher Energy Efficiency

The DVM S2 is equipped with four innovative technology components that together result in the DVM S2 delivering greater energy efficiency.





The 7th Generation of IGBT

The High-efficiency IGBT (Insulated Gate Bipolar Transistor) reduces the loss of conducted electricity.

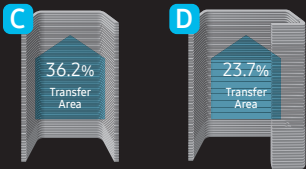

Enlarged Heat Exchanger

The enlarged Heat Exchanger can transfer more energy at once, and its optimized refrigerant path maximizes the transfer rate while minimizing any loss. These heat exchanger allow for 36.2 % greater heat transfer area on the smaller platform¹ and 23.7 % greater heat transfer on the larger platform². The power module which is an integral part of the inverter system is improved as it lowers heat dissipation and saves energy.

¹ DVM S2 equipped with larger heat exchanger than conventional model AM100JXVAGH/ET. HX Length: 1,700 mm → 1,910 mm. Platform Width: 880 → 930 [mm].
² DVM S2 equipped with larger heat exchanger than conventional model AM200KXVAGH/ET. HX Length: 2,100 mm → 2,600 mm.



Multi-serration Fan

The aerodynamic Multi-serration Fan minimizes the turbulence of the air vortex, which reduces the air resistance. The high efficiency Multi-Serration fan lowers power consumption by 32 % while providing more airflow¹. The unit uses a superior Samsung scroll compressor which makes the unit more energy efficient compared to the current DVM S range.

¹ Multi serration fan adopted for small platform. Based on 12 HP models comparison.

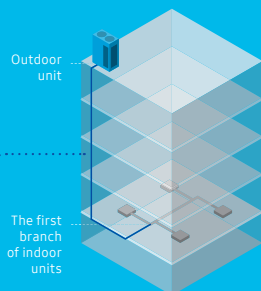
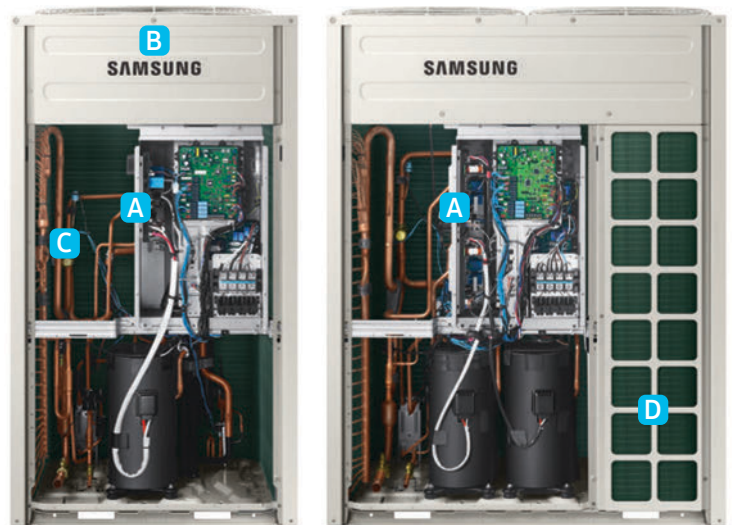

Slimmer Liquid Line (Optional Diameter Reduction)

The DVM S2 requires less refrigerant as it can use a slimmer liquid line¹. So, it saves costs on the installation and maintenance of refrigerant and piping materials. In addition, the decreasing of pipes can result in refrigerant reduction by 28 %². As long as the maximum piping length is met it is possible to install a liquid line pipe with a diameter that is one level smaller for the main run. This allows you to save on pipe and refrigerant usage.

¹ A slimmer liquid line can be used between an outdoor unit and the first branch of indoor units. The diameter of the slimmer pipe will vary depending on the diameter of the pipe that is normally used. It may not be available in certain installation conditions, and is not compatible with certain AI functions of outdoor units. Please contact Samsung's technical professionals regarding its availability and for more detailed information.
² Based on internal measurements. When a slimmer pipe, instead of a normal pipe, is used for the Main Liquid Pipe on the same capacity of air conditioning system, the amount of refrigerant to be charged can be reduced by 28 % on average.

AFI (Advanced Flash Injection) Compressor™

The Samsung AFI Compressor™ combines Flash Injection Technology with a strengthened Triple Profile Wrap and Optimal Discharge Superheat Control technology. It delivers a new level of comfort by maintaining pleasantly cool or warm conditions in every corner of a building all year round.

Flash Injection Technology increases the flow of refrigerant. So, the compressor continues working reliably, improving the heating performance even at low temperatures. Triple Profile Scroll creates a much larger chamber and can withstand higher pressure while rotating reliably at high speed. Combining it with a Dual Magnet Motor, which increases the rotary power, creates the world's largest displacement volume¹.

Optimal Discharge Superheat (DSH) Control automatically adjusts the degree of discharge superheat to heat more efficiently and effectively compared to the previous generation of DVM S.

Flash Injection Technology

Triple Profile Scroll with Dual Magnet Motor

Optimal Discharge Superheat (DSH) Control

Degree of DSH

Outdoor Temperature

Conventional Control

Optimal DSH Control

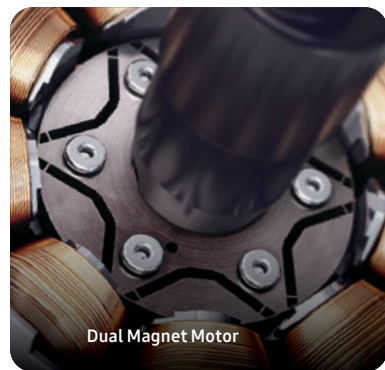
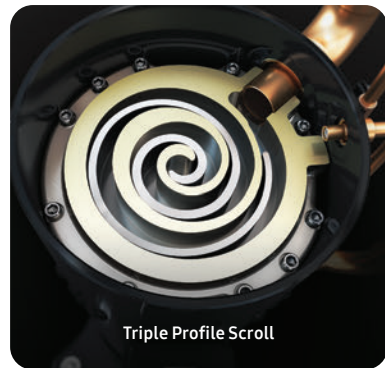
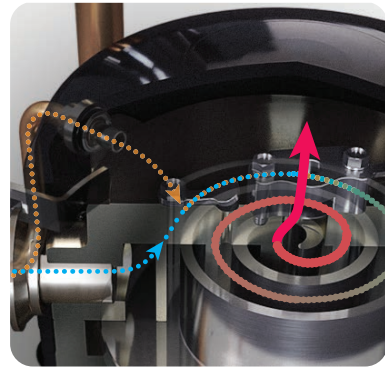

¹ Samsung circulates 14,400 cc/sec refrigerant (= 90 cc (displacement volume) x 160 rps (revolutions per second)), while Company A circulates 12,480cc/sec (= 96cc x 130rps), Company B circulates 14,080cc/sec (= 88cc x 160rps) and Company C circulates 12,320cc/sec (=88cc x 140rps).

Enhanced Emergency Operation

When the air conditioning system consists of multiple Samsung DVM S2 outdoor units, its refrigerant regulating control technology ensures that you can continue working using only one compressor in an emergency.

So, if every unit except one is not working or getting serviced and any compressor on the remaining one is working properly, it will keep cooling or heating for up to 8 hours. It ensures that you can maintain a comfortable indoor environment until the whole system is functioning properly again.

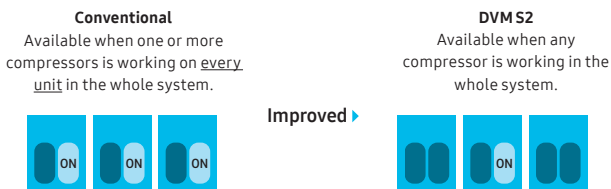

Example Cases of Malfunction	Emergency Operation	
	Conventional	DVM S2
When there are 2 or more units in a system, and one of the two compressors on a unit is not working.	Yes	Yes
When there are 2 or more units in a system, and one of the two compressors on each unit is not working.	Yes	Yes
When there are 2 or more units in a system, and all of the compressors on a unit are not working.	Not Available	Yes
When there are 2 or more units in a system, and a compressor on a low capacity unit is not working.	Not Available	Yes
When there are 2 or more units in a system, and a compressor on another unit are not working.	Not Available	Yes
When there is 1 unit in a system, and one of the two compressors on it is not working.	Not Available	Yes

Stable Performance in a Wide Range of Temperatures

The DVM S2 operates in a wider range of weather conditions, delivering a more stable performance compared to the first generation of DVM S. It operates across a wide temperature spectrum. It can cool during a heat of up to 50°C and provide warmth during freezing cold conditions of up to -25°C, ensuring a constant comfortable indoor environment throughout the year.

The wide operating range is particularly helpful as most DVM S2 will be installed on the rooftop of a building. Here the unit is directly exposed to sunlight and the radiant heat of the rooftop as well as to the discharged air of the other outdoor units.

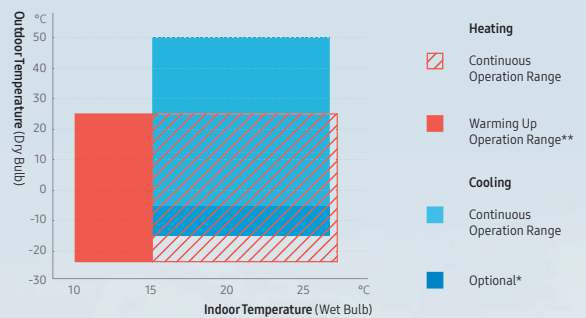

* When the 'Expand Operational Temperature Range' option is applied; the low limit of the cooling operation range can be expanded from -5°C to -15°C. Only available on HR models and under certain conditions.
 ** If the indoor temperature is lower than 15°C, it can work in heating mode but it cannot operate continuously due to a protection control, delivering thus a more stable performance than the DVM S.

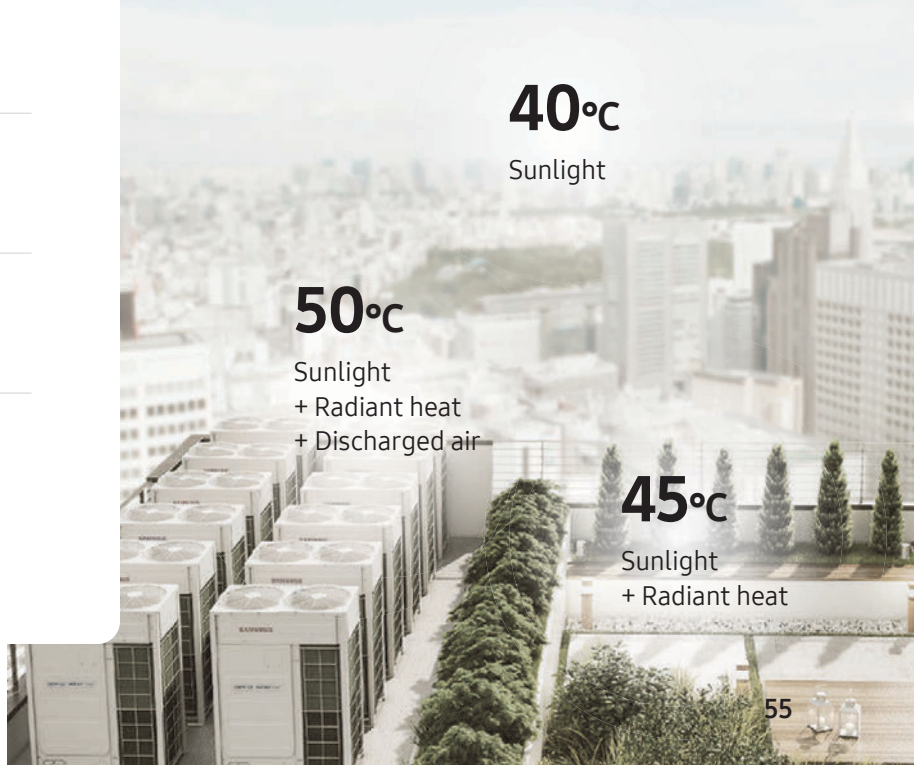

Quiet operation: improvements on core elements

The DVM S2 reduces fan noise by minimizing the air vortex due to the unique Multi-serration Fan¹. In addition, it works quietly and efficiently at night due to its quiet operation feature.

Along with the Multi-serration Fan, the Samsung DVM S2 includes a new range of technologies that support the unit's air flow optimization, namely: the Diffuser Type Discharge Plenum, Kammtail Motor Bracket and the Enlarged Heat Exchanger. Thanks to these technologies the air flows smoothly and quickly, minimizing the turbulence of the air vortex, thus resulting in less noise².

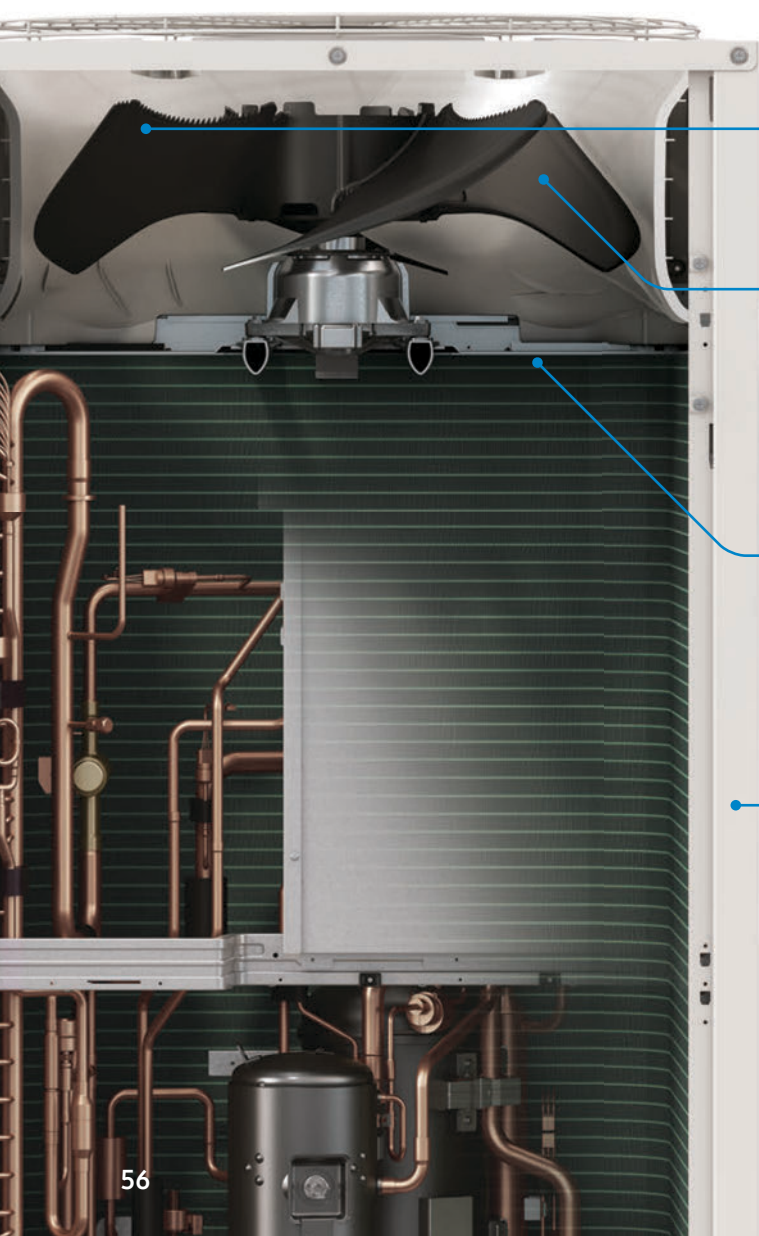

Conventional Fan
Base only



Multi-serration Fan
Base + Serration



Vorticity Magnitude

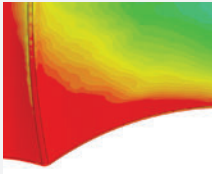

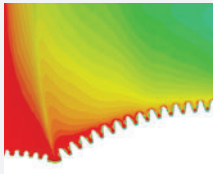



50,000
10,600
31,200
21,800
12,400

Comparison of vorticity based on the design of the edge





Diffuser Type Discharge Plenum

Conventional
Samsung DVM S2

Kammtail Motor Bracket

Conventional
Samsung DVM S2

Enlarged Heat Exchanger

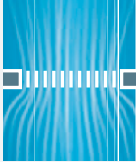
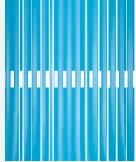

Conventional
Samsung DVM S2

¹ Only available on model of 33.6 W or less. The shape of the fan may vary by model and region.
² Based on internal testing and stimulation using a fluid dynamics software, Ansys CFX. Results may vary depending on the actual usage conditions.

Lasting Performance in Challenging Weather Conditions

The Samsung DVM S2 is equipped with the new and innovative design features that are proven to significantly enhance its durability¹. These include the robust frame, the Kammtail motor bracket and an improved structure of the legs of the unit. In addition, it features anti-corrosion capabilities on the heat

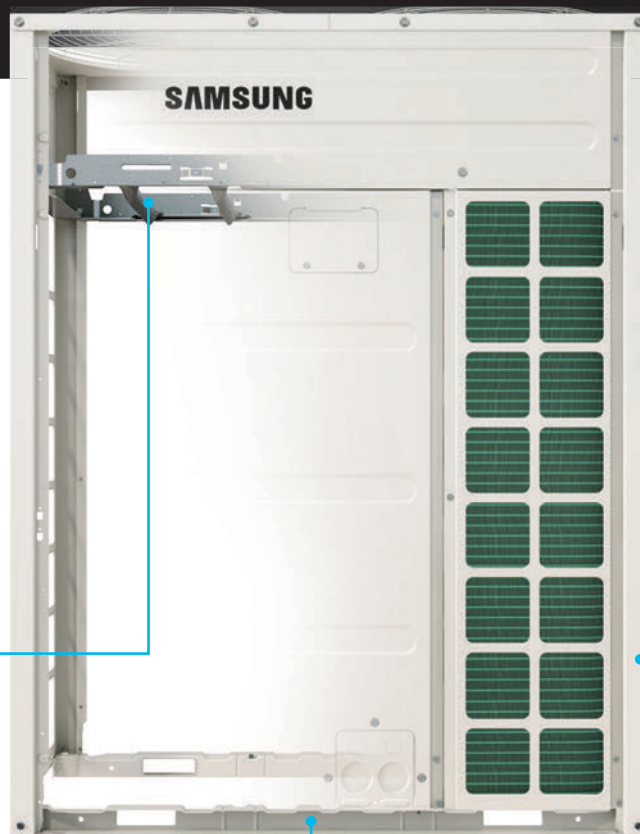
exchanger and chassis, due to the new Durafin™ Ultra fin coating, and the Galvanized Iron Steel Plate casing with a PE powder coating of up to 100µm thickness. These features were proven to ensure a maximum durability in challenging weather conditions.²

Conventional DVM S2



210%
More
Stiffness



Conventional DVM S2

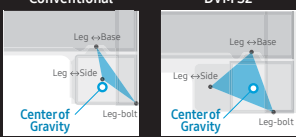

9%
More
Stiffness



Conventional DVM S2



130%
More
Stiffness

¹ Based on a test in accordance with ICC ES AC156 : 2010 (SDS=2.5g, z/h=1), conducted by SGS Korea Co., Ltd. Result Report No.: SGS-R20-1599-KR00

² Based on internal testing using corrosion chambers, Q-FOG and CCT-1100. The Complex Cycle Test (ICCT) includes cycles of spray (for 2 hours at 35°Celsius), dry (for 4 hours at 60°C s with 30% Relative Humidity) and damp (for 2 hours at 50°C with 95% Relative Humidity) conditions. As a result, the Galvanized Iron Steel Plate (GI) formed red rust after 240 hours, which is 43% slower than general Electro-Galvanized Steel Plate (EGI), which forms red rust after 168 hours.

Extended Installation Flexibility

The Samsung DVM S2 maximizes space without compromising on the quality of its performance. It is 33%¹ smaller compared to the previous DVM S generation. The DVM S2 compact design enables outdoor units to be installed even inside the building. This can be especially important for high-rise buildings. It can result in freeing up valuable amounts of space. The DVM S2 is designed to enhance installation flexibility within the building, due to the 110Pa External Static Pressure². This function effectively discharges air through a longer duct, making it a suitable choice for high-rise buildings.

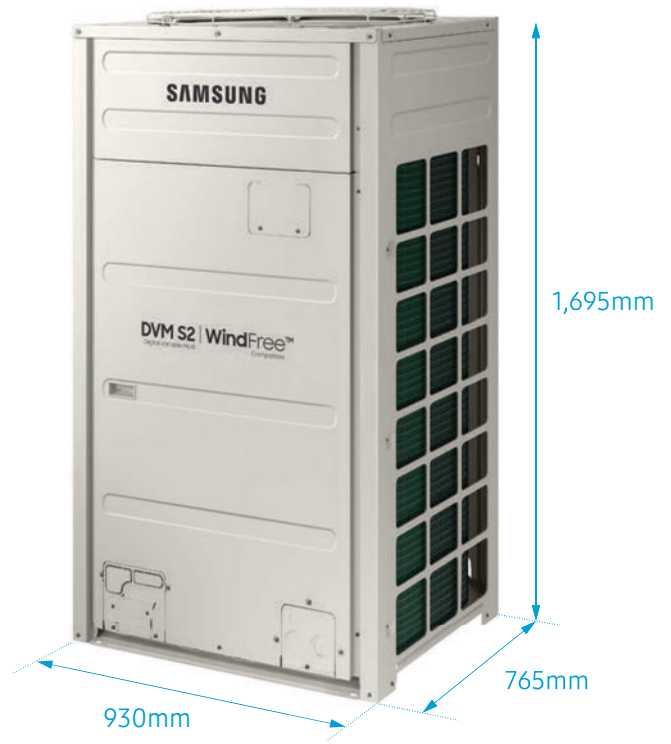
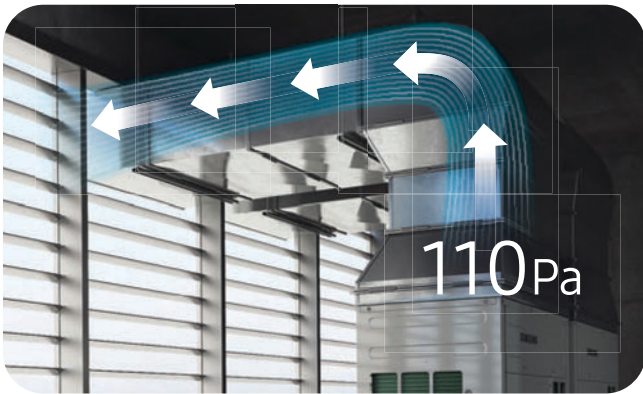

¹ Based on the AM140AXVAGH/EU, compared to the same capacity models of companies.
² May vary by model and depending on the actual condition of the ductwork and installation location. For more detailed information, please contact Samsung's technical professionals.

Convenient handling



The Samsung DVM S2 is designed to increase convenience with its updated features: the Center Point Indicator of Weight and the Simplified Cover with Handle, making it easier to transfer, install and service, while securing more safety with less effort.

In addition, it includes a service window that can be accessed easily when servicing, without opening the whole cabinet.



Fewer parts, less effort and cost for service

The Samsung DVM S2 consists of optimized modular components that come in fewer parts compared to the previous generation of Samsung's DVM S.

Based on its Quality-based Modular Design (QMD), the DVM S2 is built with high-quality modules that were preselected and preconfigured. It delivers both superior performance and reliability. Additionally, it saves up significant warehouse space, as it does not come in multiple parts.

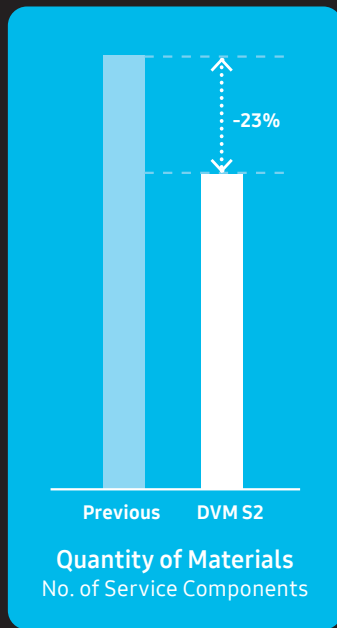

Independently Cools and Heats Multiple Spaces

An indoor unit connects to a 3-pipe Heat Recovery outdoor unit, which heats and cools independently using a Mode Control Unit (MCU). MCUs are available in configurations ranging from 1 to 12 ports and can be piped together. This allows for up to 64 indoor unit connections to a single DVM S2 system (where specifications allow).

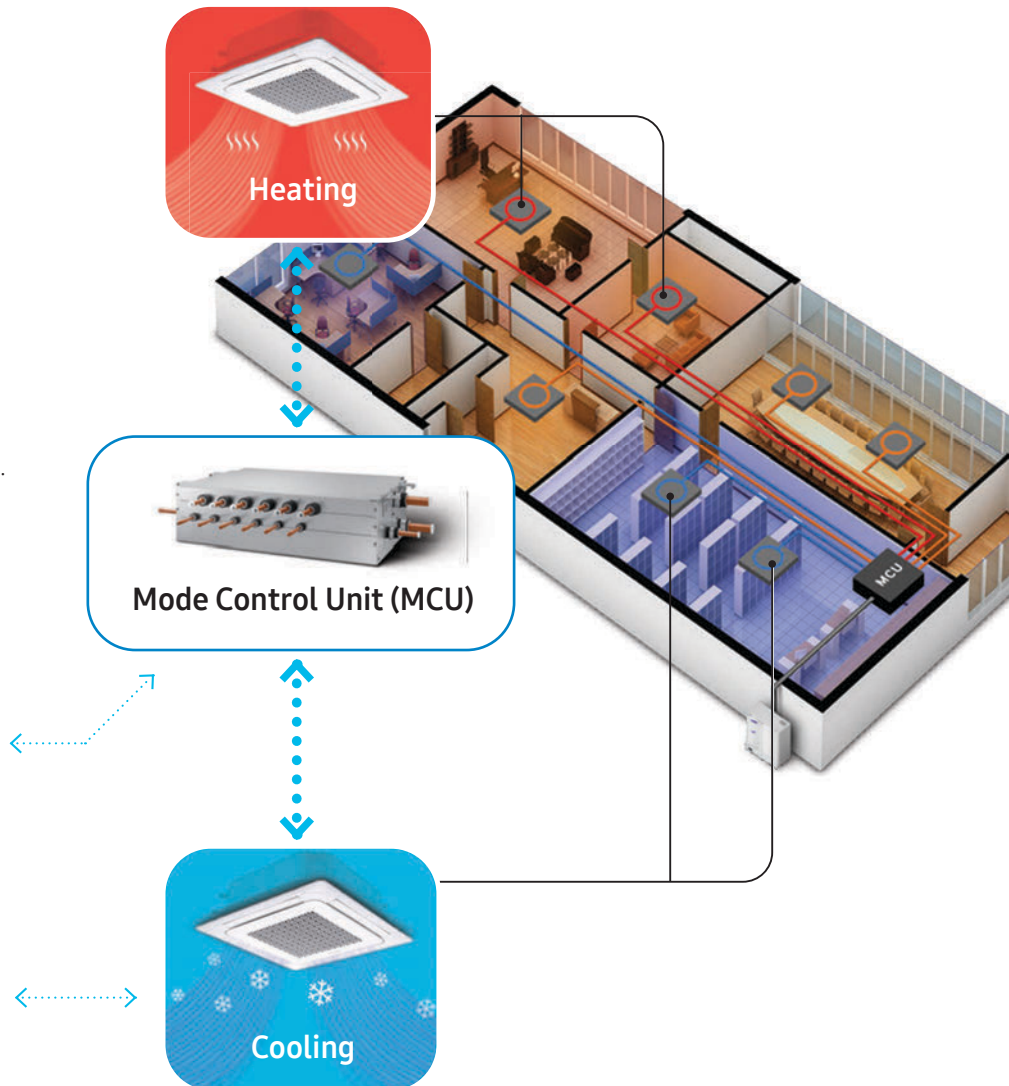
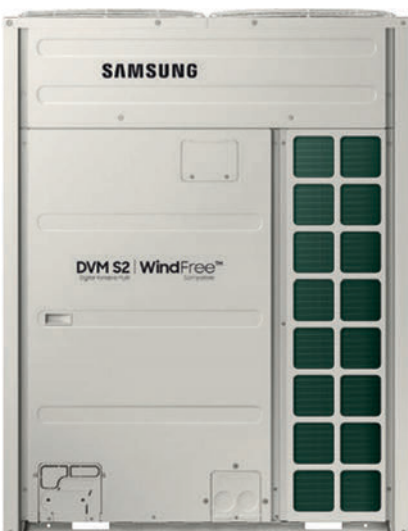





Specifications

DVM S2 Essential Heat Pump (2-Pipe, R410A)

- Erp (Ecodesign) compliant and Eurovent certified.
- Active AI Defrost.
- Optional Slimmer Liquid Pipe.
- Advanced Flash Injection™ technology.
- Active AI Refrigerant analysis.
- On-device Inverter Checker™.
- Active AI Pressure Control.
- Durafin™ Ultra Heat Exchanger Fin.



Model			AM100AXVDGH/EU	AM120AXVDGH/EU	AM140AXVDGH/EU
Power Supply		Φ, #, V, Hz	3Φ, 4, 380–415 V, 50 Hz	3Φ, 4, 380–415 V, 50 Hz	3Φ, 4, 380–415 V, 50 Hz
Performance					
HP	HP		10	12	14
Capacity	Cooling (Rated)	kW	28.0	33.6	40.0
	Heating (Rated)	kW	28.0	33.6	40.0
	Heating (Max)	kW	31.5	37.8	45.0
Maximum number of connectable indoor units		ea	18	21	26
Total capacity of the connected indoor units	Min.	kW	14.0	16.8	20.0
	Max.	kW	36.4	43.7	52.0
Power					
Current Input	Cooling (Rated)	A	20.50	22.01	28.60
	Heating (Rated)	A	14.34	16.45	20.91
Current	Minimum SSC value	MVA	3.7	4.0	4.6
	MCA	A	23.0	25.0	29.0
	MFA	A	32	32	32
Energy efficiency¹					
SEER	W/W		6.00	6.40	6.20
SCOP	W/W		4.10	4.30	4.10
ηs.c	%		237	253	245
ηs.h	%		161	169	161
Compressor					
Type	-		Inverter Scroll x 1	Inverter Scroll x 1	Inverter Scroll x 1
Output	kW x n		6.67 x 1	6.67 x 1	6.67 x 1
Oil	Type	-	PVE	PVE	PVE
	Initial Charge	cc x n	1,100 x 1	1,100 x 1	1,100 x 1
Fan					
Type	-		Propeller	Propeller	Propeller
Discharge direction	-		Vertical	Vertical	Vertical
Number of Fans	ea		1	1	1
Airflow Rate	m ³ /min		167	196	210
	l/s		2,779	3,260	3,500
External Static Pressure	Max.	mmAq	11	11	8
		Pa	110	110	80
Fan Motor					
Type	-		BLDC Motor	BLDC Motor	BLDC Motor
Output	W x n		630 x 1	630 x 1	630 x 1
Piping Connection					
Liquid Pipe	Ø, mm		9.52	12.70	12.70
	Ø, inch		3/8	1/2	1/2
Gas Pipe	Ø, mm		22.22	28.58	28.58
	Ø, inch		7/8	1 1/8	1 1/8
Piping length (ODU-IDU) ³	Max. (Equiv.)	m	200 [220]	200 [220]	200 [220]
Piping length (1st Branch - IDU) ³	Max.	m	90	90	90
Total piping length (System)	Max.	m	1,000	1,000	1,000
Level difference (ODU in highest position) ³	Max.	m	110	110	110
Level difference (IDU in highest position) ³	Max.	m	110	110	110
Level Difference (IDU-IDU) ³	Max.	m	50	50	50
Wiring Connections					
Transmission Cable	Min.	mm ²	0.75	0.75	0.75
	Remark	-	F1, F2	F1, F2	F1, F2
Refrigerant					
Type	-		R410A (Fluorinated greenhouse gas, GWP=2,088)		
Factory Charging	kg		5.5	7.0	7.0
	tCO ₂ e		11.48	14.62	14.62
Sound					
Sound Pressure ²	Cooling	dB(A)	56	61	63
	Heating	dB(A)	60	63	65
Sound Power	Cooling	dB(A)	78	81	85
External Dimensions					
Net Weight	kg		185	205	207
Net Dimensions (W x H x D)	mm		930 x 1,695 x 765	930 x 1,695 x 765	930 x 1,695 x 765
Operating Temperature Range					
Cooling	°C		-5–50	-5–50	-5–50
Heating	°C		-25–24	-25–24	-25–24



AM160AXVDGH/EU	AM180AXVDGH/EU
3Φ, 4, 380-415 V, 50 Hz	3Φ, 4, 380-415 V, 50 Hz
16	18
45.0	50.4
45.0	50.4
50.4	56.7
29	32
22.5	25.2
58.5	65.5
31.04	37.61
22.38	24.75
5.2	6.3
32.0	39.2
40	50
6.30	5.90
4.20	4.10
249	233
165	161
Inverter Scroll x 1	Inverter Scroll x 1
8.93 x 1	8.93 x 1
PVE	PVE
1,400 x 1	1,400 x 1
Propeller	Propeller
Vertical	Vertical
2	2
303	324
5,052	5,401
11	11
110	110
BLDC Motor	BLDC Motor
620 x 2	620 x 2
12.70	15.88
1/2	5/8
28.58	28.58
11/8	11/8
200 [220]	200 [220]
90	90
1,000	1,000
110	110
110	110
50	50
0.75	0.75
F1, F2	F1, F2
R410A (Fluorinated greenhouse gas, GWP=2,088)	
8.0	8.0
16.70	16.70
60	61
62	64
81	83
242	242
1,295 x 1,695 x 765	1,295 x 1,695 x 765
-5-50	-5-50
-25-24	-25-24

¹ Performances are based on the following test conditions:
 - Cooling: Indoor temperature: 27°C DB, 19°C WB, Outdoor temperature: 35°C DB, 24°C WB
 - Heating: Indoor temperature: 20°C DB, 15°C WB, Outdoor temperature: 7°C DB, 6°C WB
 - Equivalent refrigerant piping: 7.5 m, Level differences: 0 m

² Sound pressure level is obtained in an anechoic room. Sound pressure level is a relative value, depending on the distance and acoustic environment. Sound pressure level may differ according to operating conditions. Sound power level is an absolute value that a sound source generates. Sound Power: ODU and IDU operation mode is "Cooling" and hydro unit is "Heating".

³ ODU: Outdoor Unit, IDU: Indoor Unit



Specifications

DVM S2 Standard Heat Pump (2-Pipe, R410A)

- Erp (Ecodesign) compliant and Eurovent certified.
- Advanced Flash Injection™ technology.
- Active AI Pressure Control.
- Active AI Defrost.
- Active AI Refrigerant analysis.
- Durafin™ Ultra Heat Exchanger Fin.
- Optional Slimmer Liquid Pipe.
- On-device Inverter Checker™.



Model			AM080AXVAGH/EU	AM100AXVAGH/EU	AM120AXVAGH/EU
Power Supply		Φ, #, V, Hz	3Φ, 4, 380-415 V, 50 Hz	3Φ, 4, 380-415 V, 50 Hz	3Φ, 4, 380-415 V, 50 Hz
Performance					
HP		HP	8	10	12
Capacity	Cooling	kW	22.4	28.0	33.6
	Heating	kW	22.4	28.0	33.6
Maximum number of connectable indoor units		ea	14	18	21
Total capacity of the connected indoor units	Min.	kW	11.2	14.0	16.8
	Max.	kW	29.1	36.4	43.7
Power					
Current Input	Cooling	A	12.60	18.41	19.83
	Heating	A	9.50	12.90	14.82
Current	MCA	A	18.0	23.0	25.0
	MFA	A	25	32	32
Energy Efficiency¹					
SEER		W/W	6.5	6.2	6.6
SCOP		W/W	4.2	4.2	4.4
ηs,c		%	257	245	261
ηs,h		%	165	165	173
Compressor					
Output		kW x n	4.39 x 1	6.67 x 1	6.67 x 1
Oil	Type	-	PVE	PVE	PVE
	Initial Charge	cc x n	900 x 1	1,100 x 1	1,100 x 1
Fan					
Type		-	Propeller	Propeller	Propeller
Discharge direction		-	Vertical	Vertical	Vertical
Number of Fans		ea	1	1	1
Airflow Rate		m ³ /min	151	167	196
		l/s	2,515.00	2,779.00	3,260.00
External Static Pressure	Max.	mmAq	11	11	11
		Pa	110	110	110
Fan Motor					
Type		-	BLDC Motor	BLDC Motor	BLDC Motor
Output		W x n	630 x 1	630 x 1	630 x 1
Piping Connections					
Liquid Pipe		Ø, mm	9.52	9.52	12.70
		Ø, inch	3/8	3/8	1/2
Gas Pipe		Ø, mm	19.05	22.22	28.58
		Ø, inch	3/4	7/8	1 1/8
Piping length (ODU-IDU) ³	Max. (Equiv.)	m	200 [220]	200 [220]	200 [220]
Piping length (1st Branch - IDU) ³	Max.	m	90	90	90
Total piping length (System)	Max.	m	1,000	1,000	1,000
Level difference (ODU in highest position) ³	Max.	m	110	110	110
Level difference (IDU in highest position) ³	Max.	m	110	110	110
Level Difference (IDU-IDU) ³	Max.	m	50	50	50
Wiring Connections					
Transmission Cable		mm ²	0.75	0.75	0.75
Remark		-	F1, F2	F1, F2	F1, F2
Refrigerant					
Type		-	R410A (Fluorinated greenhouse gas, GWP=2,088)		
Factory Charging		kg	5.5	5.5	7.0
		tCO ₂ e	11.48	11.48	14.62
Sound					
Sound Pressure ²	Cooling	dB(A)	53	56	61
	Heating	dB(A)	58	60	63
Sound Power	Cooling	dB(A)	75	78	81
External Dimensions					
Net Weight		kg	175	185	205
Net Dimensions (W x H x D)		mm	930 x 1,695 x 765	930 x 1,695 x 765	930 x 1,695 x 765
Operating Temperature Range					
Cooling		°C	-5-50	-5-50	-5-50
Heating		°C	-25-24	-25-24	-25-24

- ¹ Performances are based on the following test conditions:
 - Cooling: Indoor temperature: 27°C DB, 19°C WB, Outdoor temperature: 35°C DB, 24°C WB
 - Heating: Indoor temperature: 20°C DB, 15°C WB, Outdoor temperature: 7°C DB, 6°C WB
 - Equivalent refrigerant piping: 7.5 m, Level differences: 0 m

² Sound pressure level is obtained in an anechoic room. Sound pressure level is a relative value, depending on the distance and acoustic environment. Sound pressure level may differ according to operating conditions. Sound power level is an absolute value that a sound source generates. Sound Power: ODU and IDU operation mode is "Cooling" and hydro unit is "Heating".

³ ODU: Outdoor Unit, IDU: Indoor Unit



	AM140AXVAGH/EU	AM160AXVAGH/EU	AM180AXVAGH/EU	AM200AXVAGH/EU	AM220AXVAGH/EU	AM240AXVAGH/EU	AM260AXVAGH/EU
	3Φ, 4, 380-415 V, 50 Hz	3Φ, 4, 380-415 V, 50 Hz	3Φ, 4, 380-415 V, 50 Hz	3Φ, 4, 380-415 V, 50 Hz	3Φ, 4, 380-415 V, 50 Hz	3Φ, 4, 380-415 V, 50 Hz	3Φ, 4, 380-415 V, 50 Hz
	14	16	18	20	22	24	26
	40.0	45.0	50.4	56.0	61.6	67.2	72.8
	40.0	45.0	50.4	56.0	61.6	67.2	68.0
	26	29	32	36	40	43	47
	20.0	22.5	25.2	28.0	30.8	33.6	36.4
	52.0	58.5	65.5	72.8	80.1	87.4	94.6
	27.72	29.47	33.87	39.87	45.43	50.05	58.83
	18.81	20.13	22.29	26.49	28.11	45.58	46.54
	29.0	32.0	39.2	43.0	46.0	55.0	60.0
	32	40	50	63	63	63	75
	6.4	6.5	6.1	6.2	5.9	5.6	5.1
	4.2	4.3	4.2	4.1	4.1	3.7	3.7
	253	257	241	245	233	221	201
	165	169	165	161	161	145	145
	6.67 x 1	8.93 x 1	8.93 x 1	8.93 x 1	6.67 x 2	6.67 x 2	6.67 x 2
	PVE	PVE	PVE	PVE	PVE	PVE	PVE
	1,100 x 1	1,400 x 1	1,400 x 1	1,400 x 1	1,100 x 2	1,100 x 2	1,100 x 2
	Propeller	Propeller	Propeller	Propeller	Propeller	Propeller	Propeller
	Vertical	Vertical	Vertical	Vertical	Vertical	Vertical	Vertical
	1	2	2	2	2	2	2
	210	303	324	313	342	365	365
	3,500.00	5,052.00	5,401.00	5,209.00	5,698.00	6,089.00	6,089.00
	8	11	11	11	11	8	8
	80	110	110	110	110	80	80
	BLDC Motor	BLDC Motor	BLDC Motor	BLDC Motor	BLDC Motor	BLDC Motor	BLDC Motor
	630 x 1	620 x 2	620 x 2	620 x 2	620 x 2	620 x 2	620 x 2
	12.70	12.70	15.88	15.88	15.88	15.88	19.05
	1/2	1/2	5/8	5/8	5/8	5/8	3/4
	28.58	28.58	28.58	28.58	28.58	34.92	34.92
	11/8	11/8	11/8	11/8	11/8	1 3/8	1 3/8
	200 [220]	200 [220]	200 [220]	200 [220]	200 [220]	200 [220]	200 [220]
	90	90	90	90	90	90	90
	1,000	1,000	1,000	1,000	1,000	1,000	1,000
	110	110	110	110	110	110	110
	110	110	110	110	110	110	110
	50	50	50	50	50	50	50
	0.75	0.75	0.75	0.75	0.75	0.75	0.75
	F1, F2	F1, F2	F1, F2	F1, F2	F1, F2	F1, F2	F1, F2
	R410A (Fluorinated greenhouse gas, GWP=2,088)						
	7.0	8.0	8.0	10.5	10.5	14.0	14.0
	14.62	16.70	16.70	21.92	21.92	29.23	29.23
	63	60	61	61	64	65	65
	65	62	64	63	65	67	67
	85	81	83	84	86	87	87
	207	242	242	268	301	325	325
	930 x 1,695 x 765	1,295 x 1,695 x 765	1,295 x 1,695 x 765	1,295 x 1,695 x 765	1,295 x 1,695 x 765	1,295 x 1,695 x 765	1,295 x 1,695 x 765
	-5-50	-5-50	-5-50	-5-50	-5-50	-5-50	-5-50
	-25-24	-25-24	-25-24	-25-24	-25-24	-25-24	-25-24

Specifications

DVM S2 High Efficiency Heat Pump (2-Pipe, R410A)

- Erp (Ecodesign) compliant and Eurovent certified.
- Advanced Flash Injection™ technology.
- Active AI Pressure Control.
- Active AI Defrost.
- Active AI Refrigerant analysis.
- Durafin™ Ultra Heat Exchanger Fin.
- Optional Slimmer Liquid Pipe.
- On-device Inverter Checker™.



Model			AM080AXVGGH/EU	AM100AXVGGH/EU	AM120AXVGGH/EU
Power Supply			3Φ, 4, 380–415 V, 50 Hz		
Performance					
HP		HP	8	10	12
Capacity	Cooling	kW	22.4	28.0	33.6
	Heating	kW	22.4	28.0	33.6
Maximum number of connectable indoor units			14	18	21
Total capacity of the connected indoor units	Min.	kW	11.2	14.0	16.8
	Max.	kW	29.1	36.4	43.7
Power					
Current Input	Cooling	A	11.44	15.97	19.25
	Heating	A	9.09	11.41	14.37
Current	Minimum SSC value	MVA	3.0	3.4	4.0
	MCA	A	18.0	21.2	25.0
	MFA	A	25	32	32
Energy Efficiency ¹					
SEER		W/W	7.2	6.9	6.9
SCOP		W/W	4.50	4.40	4.56
ηs,c		%	285	273	273
ηs,h		%	177	173	179.4
Compressor					
Output		kW x n	4.39 x 1	6.67 x 1	6.67 x 1
Oil	Type	-	PVE	PVE	PVE
	Initial Charge	cc x n	900 x 1	1,100 x 1	1,100 x 1
Fan					
Type		-	Propeller	Propeller	Propeller
Discharge direction		-	Top	Top	Top
Number of Fans		ea	1	1	1
Airflow Rate		m ³ /min	164	181	196
		l/s	2,738.00	3,019.00	3,260.00
External Static Pressure	Max.	mmAq	11	11	11
		Pa	110.00	110.00	110.00
Fan Motor					
Type		-	BLDC Motor	BLDC Motor	BLDC Motor
Output		W x n	TBD	TBD	TBD
Piping Connections					
Liquid Pipe		Ø, mm	9.52	9.52	12.70
		Ø, inch	3/8	3/8	1/2
Gas Pipe		Ø, mm	19.05	22.22	28.58
		Ø, inch	3/4	7/8	1 1/8
Piping length (ODU-IDU) ³	Max. (Equiv.)	m	200 [220]	200 [220]	200 [220]
Piping length (1st Branch - IDU) ³	Max.		90	90	90
Total piping length (System)	Max.		1,000	1,000	1,000
Level difference (ODU in highest position) ³	Max.		110	110	110
Level difference (IDU in highest position) ³	Max.		110	110	110
Level Difference (IDU-IDU) ³	Max.		50	50	50
Wiring Connections					
Transmission Cable		mm ²	0.75	0.75	0.75
Remark		-	F1, F2	F1, F2	F1, F2
Refrigerant					
Type		-	R410A (Fluorinated greenhouse gas, GWP=2,088)		
Factory Charging		kg	7.0	7.0	7.0
		tCO ₂ e	14.62	14.62	14.62
Sound					
Sound Pressure ²	Cooling	dB(A)	53	56	61
	Heating	dB(A)	58	60	63
Sound Power	Cooling	dB(A)	75	78	81
External Dimensions					
Net Weight		kg	194	205	205
Net Dimensions (W x H x D)		mm	930 x 1,695 x 765	930 x 1,695 x 765	930 x 1,695 x 765
Operating Temperature Range					
Cooling		°C	-5~50	-5~50	-5~50
Heating			-25~24	-25~24	-25~24

- ¹ Performances are based on the following test conditions:
 - Cooling: Indoor temperature: 27°C DB, 19°C WB, Outdoor temperature: 35°C DB, 24°C WB
 - Heating: Indoor temperature: 20°C DB, 15°C WB, Outdoor temperature: 7°C DB, 6°C WB
 - Equivalent refrigerant piping: 7.5 m, Level differences: 0 m

- ² Sound pressure level is obtained in an anechoic room. Sound pressure level is a relative value, depending on the distance and acoustic environment. Sound pressure level may differ according to operating conditions. Sound power level is an absolute value that a sound source generates. Sound Power: ODU and IDU operation mode is "Cooling" and hydro unit is "Heating".

- ³ ODU: Outdoor Unit, IDU: Indoor Unit



AM140AXVGGH/EU	AM160AXVGGH/EU	AM180AXVGGH/EU	AM200AXVGGH/EU	AM220AXVGGH/EU	AM240AXVGGH/EU	AM260AXVGGH/EU
3Φ, 4, 380-415 V, 50 Hz	3Φ, 4, 380-415 V, 50 Hz	3Φ, 4, 380-415 V, 50 Hz	3Φ, 4, 380-415 V, 50 Hz	3Φ, 4, 380-415 V, 50 Hz	3Φ, 4, 380-415 V, 50 Hz	3Φ, 4, 380-415 V, 50 Hz
14	16	18	20	22	24	26
40.0	45.0	50.4	56.0	61.6	67.2	72.8
40.0	45.0	50.4	56.0	61.6	67.2	68.0
26	29	32	36	40	43	47
20.0	22.5	25.2	28.0	30.8	33.6	36.4
52.0	58.5	65.5	72.8	80.1	87.4	94.6
25.44	26.96	26.79	38.63	44.15	48.62	57.61
17.06	19.35	21.14	25.72	27.29	44.20	45.11
4.4	5.2	6.4	7.0	7.4	9.3	10.2
27.0	32.0	39.2	43.0	46.0	55.0	60.0
32	40	50	63	63	63	75
6.7	6.9	7.5	6.5	6.2	5.9	5.4
4.25	4.30	4.80	4.50	4.30	3.90	3.90
265	273	297	257	245	233	213
167	169	189	177	169	153	153
6.67 x 1	8.93 x 1	8.93 x 1	8.93 x 1	6.67 x 2	6.67 x 2	6.67 x 2
PVE	PVE	PVE	PVE	PVE	PVE	PVE
1,100 x 1	1,400 x 1	1,400 x 1	1,400 x 1	1,100 x 2	1,100 x 2	1,100 x 2
Propeller	Propeller	Propeller	Propeller	Propeller	Propeller	Propeller
Top	Top	Top	Top	Top	Top	Top
2	2	2	2	2	2	2
291	292	313	313	342	365	365
4,852.00	4,866.00	5,209.00	5,209.00	5,698.00	6,089.00	6,089.00
11	11	11	11	11	8	8
110.00	110.00	110.00	110.00	110.00	80.00	80.00
BLDC Motor	BLDC Motor	BLDC Motor	BLDC Motor	BLDC Motor	BLDC Motor	BLDC Motor
TBD	TBD	TBD	TBD	TBD	TBD	TBD
12.70	12.70	15.88	15.88	15.88	15.88	19.05
1/2	1/2	5/8	5/8	5/8	5/8	3/4
28.58	28.58	28.58	28.58	28.58	34.92	34.92
11/8	11/8	11/8	11/8	11/8	1 3/8	1 3/8
200 [220]	200 [220]	200 [220]	200 [220]	200 [220]	200 [220]	200 [220]
90	90	90	90	90	90	90
1,000	1,000	1,000	1,000	1,000	1,000	1,000
110	110	110	110	110	110	110
110	110	110	110	110	110	110
50	50	50	50	50	50	50
0.75	0.75	0.75	0.75	0.75	0.75	0.75
F1, F2	F1, F2	F1, F2	F1, F2	F1, F2	F1, F2	F1, F2
R410A (Fluorinated greenhouse gas, GWP=2,088)						
8.0	10.5	10.5	10.5	10.5	14.0	14.0
16.70	21.92	21.92	21.92	21.92	29.23	29.23
58	58	59	61	64	65	65
61	61	63	63	65	67	67
81	81	81	84	86	87	87
233	262	268	268	301	325	325
1,295 x 1,695 x 765	1,295 x 1,695 x 765	1,295 x 1,695 x 765	1,295 x 1,695 x 765	1,295 x 1,695 x 765	1,295 x 1,695 x 765	1,295 x 1,695 x 765
-5-50	-5-50	-5-50	-5-50	-5-50	-5-50	-5-50
-25-24	-25-24	-25-24	-25-24	-25-24	-25-24	-25-24

Heat Recovery for DVM



Compact Heat Recovery solution

The Heat Recovery (HR) feature for Samsung DVM S and DVM S2 is designed to control temperatures in multiple spaces at once. Optimised for hotels, offices and residential buildings, it can provide cooling and heating for up to 12 indoor units simultaneously. An HR Changer is used to convert a DVM S Heat Pump (4, 5 and 6 HP) to a Heat Recovery (HR) model, which can be connected to a multiport Mode Control Unit (MCU).

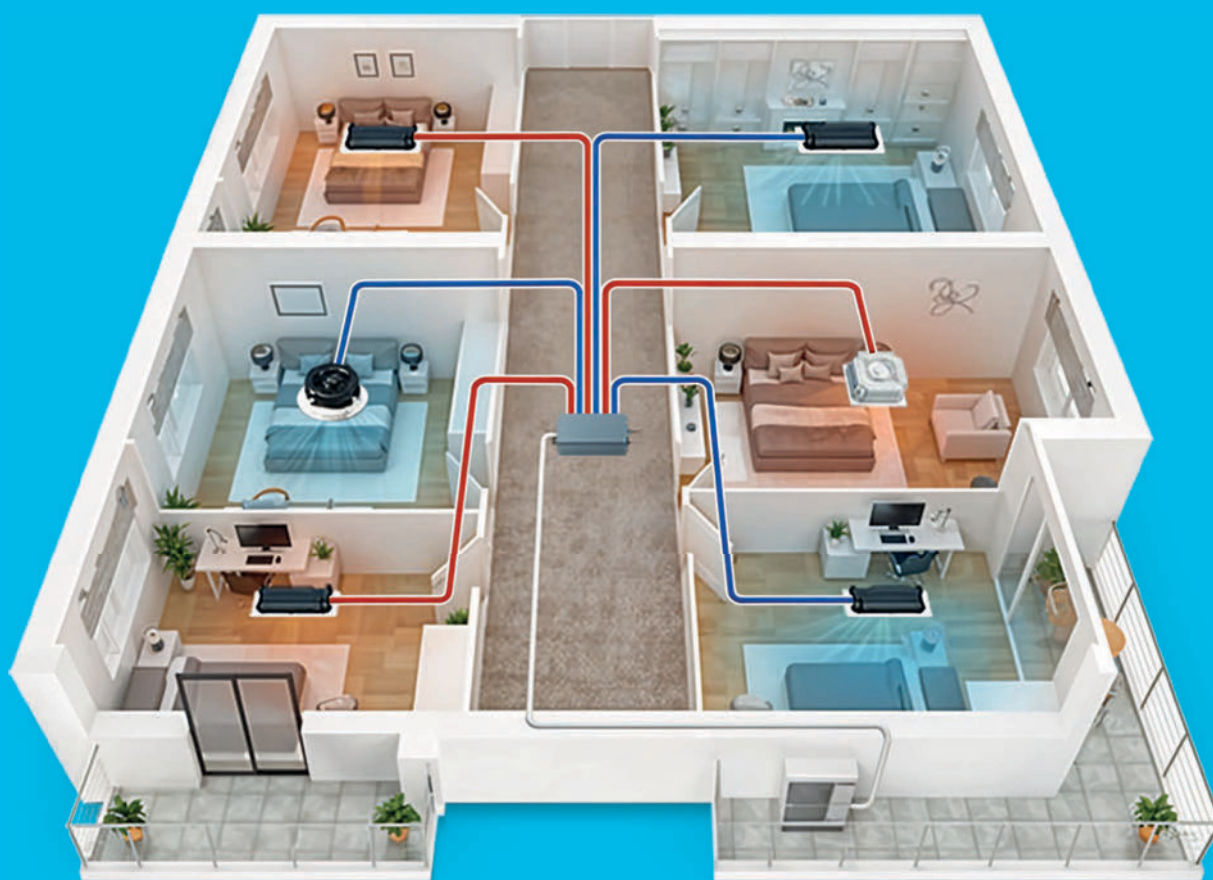



Specifications

DVM S (R410A) Heat Recovery (With Heat Recovery Changer Kit)

- Horizontal discharge and rear suction by means of two propeller BLDC Inverter fans.
- Each module houses one Twin BLDC Rotatory compressor.
- Eurovent certified and ErP (Ecodesign) compliant.
- Night Silent Mode available.
- Four-Way direction piping connection.



Model			AM040BXMDER/EU	AM050BXMDER/EU	AM060BXMDER/EU
Power Supply		Φ, V, Hz	1Φ, 220–240 V, 50 Hz	1Φ, 220–240 V, 50 Hz	1Φ, 220–240 V, 50 Hz
Performance					
HP		HP	4	5	6
Capacity	Cooling	kW	12.1	14.0	15.5
	Heating	kW	12.1	14.0	15.5
Power					
Power Input (Nominal)	Cooling	kW	3.87	5	5.74
	Heating	kW	3.04	3.83	4.43
Current Input (Nominal)	Cooling	A	17.7	22.9	26.3
	Heating	A	13.9	17.5	20.3
Current	MCA	A	22	24	30
	MFA	A	25	32	40
Energy Efficiency¹					
EER (Nominal Cooling)		W/W	3.13	2.8	2.7
COP (Nominal Heating)		W/W	3.98	3.66	3.5
SEER (Cassette)		W/W	7.9	7.4	7.75
SCOP (Cassette)		W/W	4.65	4.65	4.9
Compressor					
Type	-		Twin BLDC Rotary	Twin BLDC Rotary	Twin BLDC Rotary
Output		kW x n	4.04 x 1	4.04 x 1	4.04 x 1
Oil	Type	-	PVE	PVE	PVE
	Initial Charge	cc	1,700	1,700	1,700
Fan					
Type & Discharge direction		-	Propeller	Propeller	Propeller
		-	Horizontal	Horizontal	Horizontal
Number of Fans		ea	2	2	2
Airflow Rate	(H/M/L)	m ³ /min	100	100	100
		l/s	1,667	1,667	1,667
External Static Pressure	Max.	mmAq	3	3	3
		Pa	29.4	29.4	29.4
Fan Motor					
Model	-		BLDC Motor	BLDC Motor	BLDC Motor
Output x n		W x n	125.0 x 2	125.0 x 2	125.0 x 2
Piping Connections					
Liquid Pipe		Ø, mm	9.52	9.52	9.52
		Ø, inch	3/8	3/8	3/8
Gas Pipe		Ø, mm	15.88	15.88	15.88
		Ø, inch	5/8	5/8	5/8
Discharge Gas Pipe		Ø, mm	19.05	19.05	19.05
		Ø, inch	3/4	3/4	3/4
Piping length (ODU-IDU)	Max. [Equiv.]	m	150 (75)	150 (75)	150 (75)
Piping length (1st Branch-IDU)	Max	m	40	40	40
Total Piping length (System)	Max	m	300	300	300
Level difference (ODU in highest position)	Max	m	50	50	50
Level difference (IDU in highest position)	Max	m	40	40	40
Level difference (IDU-ODU)	Max	m	50	50	50
Wiring Connections					
Communication	Min.	m	0.75	0.75	0.75
	Remark	-	F1, F2	F1, F2	F1, F2
Refrigerant					
Type	-		R410A (Fluorinated greenhouse gas, GWP=2,088)		
Factory Charging		kg	3.2	3.2	3.3
		kg / tCO ₂ e	6.68	6.68	6.89
Sound					
Sound Pressure ² (Cooling)		dB(A)	51	52	53
Sound Pressure ² (Heating)		dB(A)	55	55	55
Sound Power		dB(A)	68	69	70
External Dimensions					
Net Weight		kg	97	97	100
Net Dimensions (W x H x D)		mm	940 x 1,210 x 330	940 x 1,210 x 330	940 x 1,210 x 330
Operating Temperature Range					
Cooling		°C	-5.0–48.0	-5.0–48.0	-5.0–48.0
Heating		°C	-25.0–26.0	-25.0–26.0	-25.0–26.0



AM040BXMDGR/EU	AM050BXMDGR/EU	AM060BXMDGR/EU
3Φ, 380-415 V, 50 Hz	3Φ, 380-415 V, 50 Hz	3Φ, 380-415 V, 50 Hz
4	5	6
12.1	14.0	15.5
12.1	14.0	15.5
3.87	5	5.74
3.04	3.83	4.43
5.9	7.6	8.7
4.6	5.8	6.7
16.1	16.1	16.1
20	20	20
3.13	2.8	2.7
3.98	3.66	3.5
7.9	7.4	7.75
4.65	4.65	4.9
Twin BLDC Rotary	Twin BLDC Rotary	Twin BLDC Rotary
4.04 x 1	4.04 x 1	4.04 x 1
PVE	PVE	PVE
1,700	1,700	1,700
Propeller	Propeller	Propeller
Horizontal	Horizontal	Horizontal
2	2	2
100	100	100
1,667	1,667	1,667
3	3	3
29.4	29.4	29.4
BLDC Motor	BLDC Motor	BLDC Motor
125.0 x 2	125.0 x 2	125.0 x 2
9.52	9.52	9.52
3/8	3/8	3/8
15.88	15.88	15.88
5/8	5/8	5/8
19.05	19.05	19.05
3/4	3/4	3/4
150 (75)	150 (75)	150 (75)
40	40	40
300	300	300
50	50	50
40	40	40
50	50	50
0.75	0.75	0.75
F1, F2	F1, F2	F1, F2
R410A (Fluorinated greenhouse gas, GWP=2,088)		
3.2	3.2	3.3
6.68	6.68	6.89
51	52	53
55	55	55
68	69	70
95	95	98
940 x 1,210 x 330	940 x 1,210 x 330	940 x 1,210 x 330
-5.0-48.0	-5.0-48.0	-5.0-48.0
-25.0-26.0	-25.0-26.0	-25.0-26.0

¹ Performances are based on the following test conditions:
 - Cooling: Indoor temperature: 27°C DB, 19°C WB, Outdoor temperature: 35°C DB, 24°C WB
 - Heating: Indoor temperature: 20°C DB, 15°C WB, Outdoor temperature: 7°C DB, 6°C WB
 - Equivalent refrigerant piping: 7.5 m, Level differences: 0 m

² Sound pressure level is obtained in an anechoic room. Sound pressure level is a relative value, depending on the distance and acoustic environment. Sound pressure level may differ according to operating conditions. Sound power level is an absolute value that a sound source generates. Sound Power: ODU and IDU operation mode is "Cooling" and hydro unit is "Heating".



Specifications

DVM S2 High EER Heat Recovery (3-Pipe, R410A)

- Erp (Ecodesign) compliant and Eurovent certified.
- Advanced Flash Injection™ technology.
- Active AI Pressure Control.
- Active AI Defrost.
- Active AI Refrigerant analysis.
- Durafin™ Ultra Heat Exchanger Fin.
- Optional Slimmer Liquid Pipe.
- On-device Inverter Checker™.



Model			AM080AXVGGR/EU	AM100AXVGGR/EU	AM120AXVGGR/EU
Power Supply	Φ, #, V, Hz		3Φ, 4, 380-415 V, 50 Hz	3Φ, 4, 380-415 V, 50 Hz	3Φ, 4, 380-415 V, 50 Hz
Mode	-		HEAT RECOVERY	HEAT RECOVERY	HEAT RECOVERY
Performance					
HP	HP		8	10	12
Capacity	Cooling	kW	22.4	28.0	33.6
	Heating	kW	22.4	28.0	33.6
Maximum number of connectable indoor units	ea		14	18	21
Total capacity of the connected indoor units	Min.	kW	11.2	14.0	16.8
	Max.	kW	29.1	36.4	43.7
Power					
Current Input	Cooling	A	11.44	15.97	19.25
	Heating	A	9.09	11.41	14.37
Current	Minimum SSC value	MVA	3.0	3.4	4.0
	MCA	A	18.0	21.1	25.0
	MFA	A	25	32	32
Energy Efficiency¹					
SEER	W/W		7.2	6.9	6.9
SCOP	W/W		4.5	4.4	4.56
ηs.c	%		285	273	273
ηs.h	%		177	173	179.4
Compressor					
Output	-		4.39 x 1	6.67 x 1	6.67 x 1
Oil	Type	-	PVE	PVE	PVE
	Initial Charge	cc x n	900 x 1	1,100 x 1	1,100 x 1
Fan					
Type	-		Propeller	Propeller	Propeller
Discharge direction	-		Top	Top	Top
Number of Fans	ea		1	1	1
Airflow Rate	m ³ /min		164	181	196
	l/s		2,738	3,019	3,260
External Static Pressure	Max.	mmAq	11	11	11
		Pa	110	110	110
Fan Motor					
Type	-		BLDC Motor	BLDC Motor	BLDC Motor
Output	W x n		630 x 1	630 x 1	630 x 1
Piping Connections					
Liquid Pipe	Ø, mm		9.52	9.52	12.70
	Ø, inch		3/8	3/8	1/2
Gas Pipe	Ø, mm		19.05	22.22	28.58
	Ø, inch		3/4	7/8	1 1/8
High Pressure Gas Pipe (HR Only)	Ø, mm		15.88	19.05	19.05
	Ø, inch		5/8	3/4	3/4
Piping length (ODU-IDU) ³	Max. (Equiv.)	m	200 [220]	200 [220]	200 [220]
Piping length (1st Branch - IDU) ³	Max.	m	90	90	90
Total piping length (System)	Max.	m	1,000	1,000	1,000
Level Difference (ODU in highest position) ³	Max.	m	110	110	110
Level Difference (IDU in highest position) ³	Max.	m	110	110	110
Level Difference (IDU-IDU) ³	Max.	m	50	50	50
Wiring Connections					
Transmission Cable	mm ²		0.75	0.75	0.75
Remark	-		F1, F2	F1, F2	F1, F2
Refrigerant					
Type	-		R410A (Fluorinated greenhouse gas, GWP=2,088)		
Factory Charging	kg		7.0	7.0	7.0
	tCO ₂ e		14.62	14.62	14.62
Sound					
Sound Pressure ²	Cooling	dB(A)	53	56	61
	Heating	dB(A)	58	60	63
Sound Power	dB(A)		75	78	81
External Dimensions					
Net Weight	kg		199	211	211
Net Dimensions (W x H x D)	mm		930 x 1,695 x 765	930 x 1,695 x 765	930 x 1,695 x 765
Operating Temperature Range					
Cooling	°C		-5-50	-5-50	-5-50
Heating	°C		-25-24	-25-24	-25-24

- ¹ Performances are based on the following test conditions:
- Cooling: Indoor temperature: 27°C DB, 19°C WB, Outdoor temperature: 35°C DB, 24°C WB
 - Heating: Indoor temperature: 20°C DB, 15°C WB, Outdoor temperature: 7°C DB, 6°C WB
 - Equivalent refrigerant piping: 7.5 m, Level differences: 0 m

- ² Sound pressure level is obtained in an anechoic room. Sound pressure level is a relative value, depending on the distance and acoustic environment. Sound pressure level may differ according to operating conditions. Sound power level is an absolute value that a sound source generates. Sound Power: ODU and IDU operation mode is "Cooling" and hydro unit is "Heating".

- ³ ODU: Outdoor Unit, IDU: Indoor Unit



AM140AXVGGR/EU	AM160AXVGGR/EU	AM180AXVGGR/EU	AM200AXVGGR/EU	AM220AXVGGR/EU	AM240AXVGGR/EU	AM260AXVGGR/EU
3Φ, 4, 380-415 V, 50 Hz	3Φ, 4, 380-415 V, 50 Hz	3Φ, 4, 380-415 V, 50 Hz	3Φ, 4, 380-415 V, 50 Hz	3Φ, 4, 380-415 V, 50 Hz	3Φ, 4, 380-415 V, 50/60 Hz	3Φ, 4, 380-415 V, 50/60 Hz
HEAT RECOVERY	HEAT RECOVERY	HEAT RECOVERY	HEAT RECOVERY	HEAT RECOVERY	HEAT RECOVERY	HEAT RECOVERY
14	16	18	20	22	24	26
40.0	45.0	50.4	56.0	61.6	67.2	72.8
40.0	45.0	50.4	56.0	61.6	67.2	68.0
26	29	32	36	40	43	47
20.0	22.5	25.2	28.0	30.8	33.6	36.4
52.0	58.5	65.5	72.8	80.1	87.4	94.6
25.44	26.96	26.79	38.63	44.15	48.62	57.61
17.06	19.35	21.14	25.72	27.29	44.20	45.11
4.4	5.2	6.4	7.0	7.4	9.3	10.2
27.0	32.0	39.2	43.0	46.0	55.0	60.0
32	40	50	63	63	63	75
6.7	6.9	7.5	6.5	6.2	5.9	5.4
4.25	4.3	4.8	4.5	4.3	3.9	3.9
265	273	297	257	245	233	213
167	169	189	177	169	153	153
6.67 x 1	8.93 x 1	8.93 x 1	8.93 x 1	6.67 x 2	6.67 x 2	6.67 x 2
PVE	PVE	PVE	PVE	PVE	PVE	PVE
1,100 x 1	1,400 x 1	1,400 x 1	1,400 x 1	1,100 x 2	1,100 x 2	1,100 x 2
Propeller	Propeller	Propeller	Propeller	Propeller	Propeller	Propeller
Top	Top	Top	Top	Top	Top	Top
2	2	2	2	2	2	2
291	292	313	313	342	365	365
4,852	4,866	5,209	5,209	5,698	6,089	6,089
11	11	11	11	11	8	8
110	110	110	110	110	80	80
BLDC Motor	BLDC Motor	BLDC Motor	BLDC Motor	BLDC Motor	BLDC Motor	BLDC Motor
620 x 2	620 x 2	620 x 2	620 x 2	620 x 2	620 x 2	620 x 2
12.70	12.70	15.88	15.88	15.88	15.88	19.05
1/2	1/2	5/8	5/8	5/8	5/8	3/4
22.22	28.58	28.58	28.58	28.58	34.92	34.92
7/8	11/8	11/8	11/8	11/8	13/8	13/8
22.22	22.22	22.22	28.58	28.58	28.58	28.58
7/8	7/8	7/8	1-1/8	1-1/8	1-1/8	1-1/8
200 [220]	200 [220]	200 [220]	200 [220]	200 [220]	200 [220]	200 [220]
90	90	90	90	90	90	90
1,000	1,000	1,000	1,000	1,000	1,000	1,000
110	110	110	110	110	110	110
110	110	110	110	110	110	110
50	50	50	50	50	50	50
0.75	0.75	0.75	0.75	0.75	0.75	0.75
F1, F2	F1, F2	F1, F2	F1, F2	F1, F2	F1, F2	F1, F2
R410A (Fluorinated greenhouse gas, GWP=2,088)						
8.0	10.5	10.5	10.5	10.5	14.0	14.0
16.70	21.92	21.92	21.92	21.92	29.23	29.23
58	58	59	61	64	65	65
61	61	63	63	65	67	67
81	81	81	84	86	87	87
237	268	274	274	309	332	332
1,295 x 1,695 x 765	1,295 x 1,695 x 765	1,295 x 1,695 x 765	1,295 x 1,695 x 765	1,295 x 1,695 x 765	1,295 x 1,695 x 765	1,295 x 1,695 x 765
-5-50	-5-50	-5-50	-5-50	-5-50	-5-50	-5-50
-25-24	-25-24	-25-24	-25-24	-25-24	-25-24	-25-24



DVM S Water

Optimal Water Flow Controller

The DVM S Water comes with a built-in Water Flow Controller that helps control the amount of water used to cool and heat an outdoor unit. The optimum flow of water is automatically determined by the temperature of the indoor space, making for minimum energy consumption at optimum standards, at reduced costs. And because this feature is standard, there is no need for a separate water flow control kit.



Geothermal applications

DVM S Water gives an effective and reliable performance using water as a means of heat exchange. It can be connected through a heat exchanger to multiple natural sources like geothermal loops, seawater or lakes.

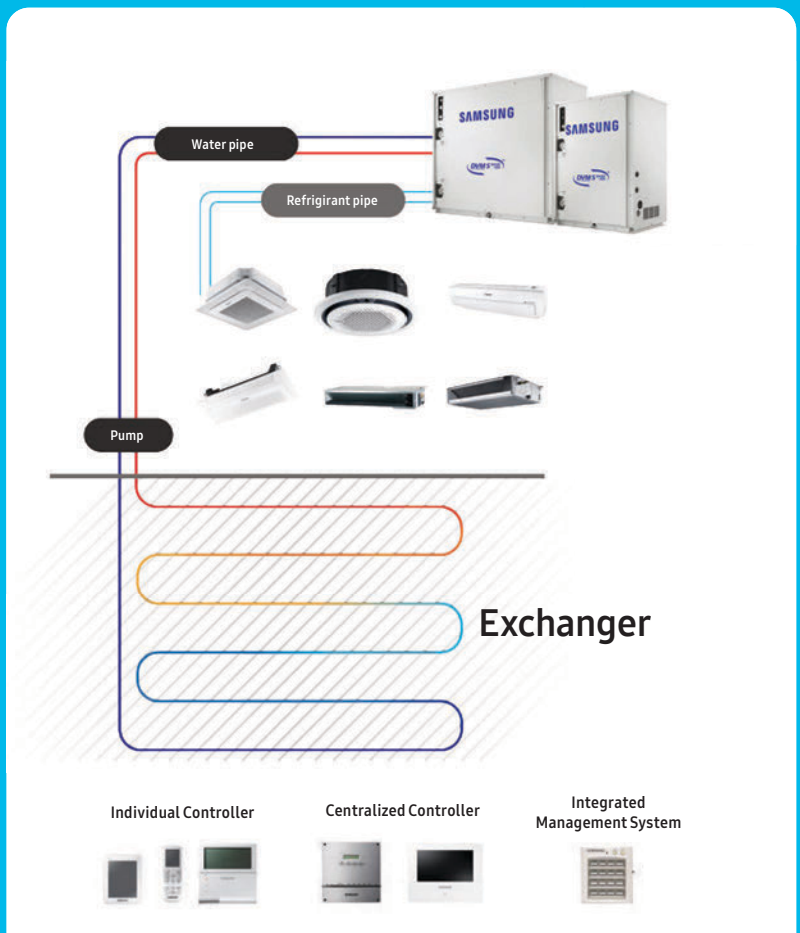

Specifications

DVM S Water (R410A)

- Water Cooled, Variable Refrigerant Flow Heat Pump/Heat Recovery Unit R410A.
- Suitable for indoor and outdoor installation.
- Each unit houses one (8-12 HP) or two (20~30 HP) Inverter Scroll compressors with Flash Injection technology.



Model				AM080MXWANR/EU	AM100MXWANR/EU	AM120MXWANR/EU
Power Supply		Φ, #, V, Hz		3Φ, 4, 380-415 V, 50/60 Hz	3Φ, 4, 380-415 V, 50/60 Hz	3Φ, 4, 380-415 V, 50/60 Hz
Performance						
HP		HP		8	10	12
Capacity (Nominal)	Cooling	kW		22.4	28.0	33.6
	Heating	kW		25.2	31.5	37.8
Maximum number of connectable indoor units		ea		14	18	22
Total capacity of the connected indoor units	Min.	kW		11.2	14.0	16.8
	Max.	kW		29.1	36.4	43.7
Power						
Power Input (Nominal)	Cooling	kW		3.67	4.87	6.00
	Heating	kW		3.97	5.04	6.25
Current Input (Nominal)	Cooling	A		5.9	8.1	9.6
	Heating	A		6.4	8.4	10.0
Current	Minimum SSC value		MVA	3.9	3.9	4.8
	MCA		A	16.1	16.1	20.0
	MFA		A	20	20	25
COP						
Nominal Cooling		W/W		6.10	5.75	5.60
Nominal Heating		W/W		6.35	6.25	6.05
Compressor						
Type		-		Inverter Scroll	Inverter Scroll	Inverter Scroll
Output		kW × n		4.96 x 1	4.96 x 1	6.13 x 1
Oil	Type		-	PVE	PVE	PVE
	Initial Charge		cc	3,900	3,900	3,900
Condenser						
Type		-		Plate Heat Exchanger	Plate Heat Exchanger	Plate Heat Exchanger
Pipe Size		Ø, inch		PT11/4	PT11/4	PT11/4
Pressure Drop		kPa		22	30	43
Water Flow Rate		l/min		80	96	114
Max. Pressure		MPa		1.96	1.96	1.96
Liquid Pipe	Ø, mm			9.52	9.52	12.70
	Ø, inch			3/8	3/8	1/2
Gas Pipe	Ø, mm			19.05	22.22	28.58
	Ø, inch			3/4	7/8	1 1/8
Piping Connections						
Discharge Gas Pipe		Ø, mm		15.88	19.05	19.05
		Ø, inch		5/8	3/4	3/4
Piping length	Outdoor-Indoor	Max.	m	170 (190)	170 (190)	170 (190)
	After branch	Max.	m	90	90	90
Total piping length	System	Actual	m	500	500	500
Level difference	Outdoor-Indoor	Outdoor unit in highest position	m	50	50	50
		Indoor unit in highest position	m	40	40	40
	Indoor-Indoor	Max.	m	50	50	50
Wiring Connections						
Communication		Minimum		mm ²	0.75	0.75
Remark		-			F1, F2	F1, F2
Refrigerant						
Type		-		R410A (Fluorinated greenhouse gas, GWP=2,088)		
Factory Charging	kg			5.5	5.8	6.0
	tCO ₂ e			11.48	12.11	12.53
Sound						
Sound Pressure ²	Cooling	dB(A)		48	48	50
	Heating	dB(A)		51	51	52
Sound Power		dB(A)		70	70	70
External Dimensions						
Net Weight		kg		160.0	160.0	160.0
Net Dimensions (W x H x D)		mm		770 x 1,000 x 545	770 x 1,000 x 545	770 x 1,000 x 545
Operating Temperature Range						
Cooling		°C		10.0-45.0	10.0-45.0	10.0-45.0
Heating		°C		10.0-45.0	10.0-45.0	10.0-45.0



AM200KXWANR/EU	AM300KXWANR/EU
3Φ, 4, 380-415 V, 50/60 Hz	3Φ, 4, 380-415 V, 50/60 Hz
20	30
56.0	84
63	94.5
36	55
28.0	42.0
72.8	109.2
10.77	16.80
10.86	16.88
17.3	26.4
17.4	26.5
7.7	-
32.2	48.0
40	63
5.20	5.00
5.80	5.60
Inverter Scroll	SSC Scroll x 2
4.96 x 2	6.75 x 2
PVE	PVE
6,200	6,200
Plate Heat Exchanger	Plate Heat Exchanger
PT11/4	PT2
54	50
190	285
1.96	1.96
15.88	19.05
5/8	3/4
28.58	34.92
11/8	1 3/8
28.58	28.58
11/8	11/8
170 (190)	170 (190)
90	90
500	500
50	50
40	40
50	50
0.75	0.75
F1, F2	F1, F2
R410A (Fluorinated greenhouse gas, GWP=2,088)	
9.8	11.0
20.46	22.96
51	55
52	58
73	75
240.0	280.0
1,100 x 1,000 x 545	1,100 x 1,000 x 545
10.0-45.0	10.0-45.0
10.0-45.0	10.0-45.0

¹ Performances are based on the following test conditions:
 - Cooling: Indoor temperature: 27°C DB, 19°C WB, Inlet water temperature: 30°C
 - Heating: Indoor temperature: 20°C DB, 15°C WB, Inlet water temperature: 20°C
 - Equivalent refrigerant piping: 7.5 m, Level differences: 0 m

² Sound pressure level is obtained in an anechoic room. Sound pressure level is a relative value, depending on the distance and acoustic environment. Sound pressure level may differ according to operating conditions. Sound power level is an absolute value that a sound source generates. Sound Power: ODU and IDU operation mode is "Cooling" and hydro unit is "Heating".













Indoor Units VRF





Line-up indoor ^{1/2}

Universal R32 & R410A

Model	Image	Capacity (kW)								
		1.5	1.7	2.2	2.8	3.6	4.5	5.6	6.0	7.1
Cassette NEW										
WindFree™ 1-Way Cassette			•	•	•	•		•		•
WindFree™ Mini 4-Way Cassette		•		•	•	•	•	•	•	
WindFree™ 4-Way Cassette					•	•	•	•		•
Sensible WindFree™ 4-Way Cassette				•	•	•	•	•		•
360 Cassette								•	•	•
Ducted NEW										
LSP Duct (drain pump included)			•	•	•	•	•	•		•
MSP Duct (drain pump included)				•	•	•	•	•		•
Sensible MSP Duct (drain pump included)				•	•	•	•	•		•
HSP Duct										
Ceiling NEW										
Floor/Ceiling								•		
Big Ceiling										•
Wall-Mounted NEW										
WindFree™ Deluxe (EEV included)		•		•	•	•	•	•		•
Max Wall-Mounted										









NOTE

- Universal indoor units, universal controller and universal accessories can be installed both with DVM R410A and DVM R32 Outdoor units.
- Make sure to use an indoor unit that is compatible with DVM S2.
- Indoor units can be connected within the range indicated in the following table.
- If the total capacity of the connected indoor units exceeds the indicated maximum capacity, the cooling and heating capacity of the indoor unit may decrease.
- The total allowable capacity of the connected indoor units can be from 50 % to 130 % of the total outdoor unit capacity. $0.5 \times \Sigma (\text{Outdoor unit capacity}) \leq \text{Total capacity of the connected indoor units} \leq 1.3 \times \Sigma (\text{Outdoor unit capacity})$.
- EEV kit is necessary for all Indoor Units which do not have EEV kit included, please order EEV Kit separately.

Capacity (kW)												
	8.2	9.0	11.2	12.8	14.0	16.0	18.0	22.0	25.0	28.0	32.0	50.0
		•	•	•	•							
		•	•	•	•							
		•	•	•	•	•						
		•	•	•	•							
			•		•							
	•											
		•										

Line-up indoor ^{2/2}

R410A

Model	Image	Capacity (kW)									
		1.5	1.7	2.2	2.8	3.6	4.5	5.6	6.0	7.1	
Ducted											
LSP Duct (drain pump excluded) R410A			•	•	•	•	•	•		•	
HSP Duct R410A											
Wall-Mounted											
WindFree™ Deluxe (EEV excluded) R410A		•		•	•	•	•	•		•	
Floor Standing											
Console R410A				•	•	•	•	•			
Concealed Floor-Standing R410A							•	•		•	
Packaged Floor-Standing R410A											
Hydro Unit											
Hydro Unit HE R410A											
Hydro Unit HT R410A											

NOTE

- Make sure to use an indoor unit that is compatible with DVM S2.
- Indoor units can be connected within the range indicated in the following table.
- If the total capacity of the connected indoor units exceeds the indicated maximum capacity, the cooling and heating capacity of the indoor unit may decrease.
- The total allowable capacity of the connected indoor units can be from 50 % to 130 % of the total outdoor unit capacity. $0.5 \times \Sigma (\text{Outdoor unit capacity}) \leq \text{Total capacity of the connected indoor units} \leq 1.3 \times \Sigma (\text{Outdoor unit capacity})$.
- EEV kit is necessary for all Indoor Units which do not have EEV kit included, please order EEV Kit separately.

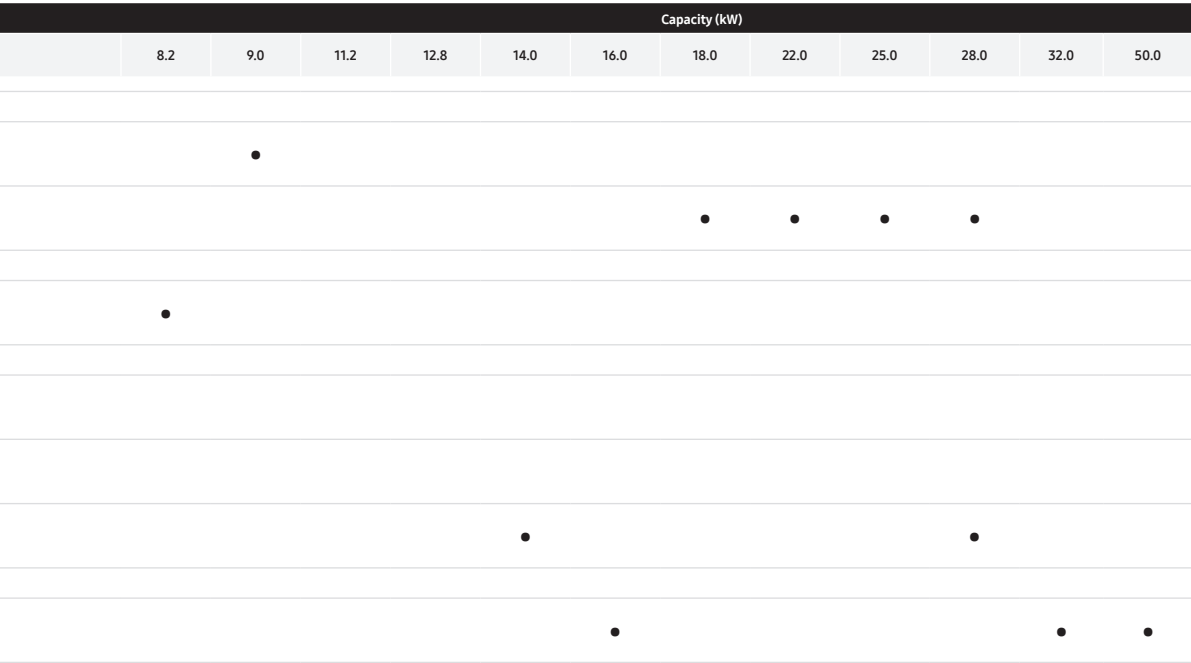

WindFree™ 4-Way Cassette

UNIQUE



WindFree™
4-Way 600 x 600 Cassette

9,000 micro-holes

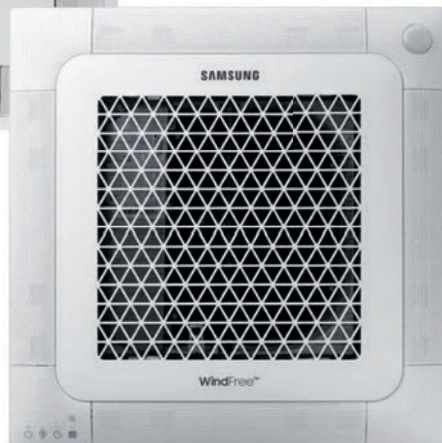

WindFree™
4-Way Cassette

15,700 micro-holes

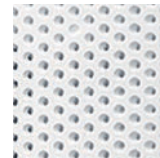

WindFree™ Technology

The WindFree™ 4-Way Cassette directs air through 15,700 micro-holes in the panel, while the WindFree™ 4-Way 600 x 600 Cassette directs air through 9,000 micro-holes in the panel. These micro-holes are essential for creating a type of airflow called “Still Air”¹ which cools the room gradually and noticeably without drafts.

The WindFree™ 4-Way Cassette is now available in FCU.

¹ ASHRAE (American Society of Heating, Refrigeration, and Air-Conditioning Engineers) defines “Still Air” as air currents at speeds below 0.15 m/s which lacks the presence of cold drafts.

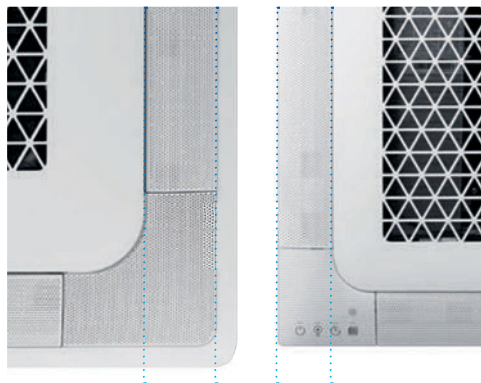

|←→|
84mm

|←→|
66mm

Optimised blades

The larger optimised blades¹ (84 mm WindFree™ 4-Way Cassette, 66 mm WindFree™ 4-Way 600 x 600 Cassette) facilitate a wider cooling range and improved air circulation within the room. This advanced technology also cools the space much faster leaving no zone untouched. These blades are detachable and can be washed easily with water to remove dust or debris that has collected on them, therefore allowing for optimal quality of airflow that in turn helps maintain a cleaner environment.

¹ Samsung testing compares the WindFree™ 4-Way and WindFree™ 4-Way 600 x 600 Cassette to a previous 4-Way Cassette type air conditioner.

Smart Comfort Operation

The WindFree™ 4-Way Cassette and the WindFree™ 4-Way 600 x 600 Cassette boosts Smart Comfort Operation. The Fast Cooling process helps to achieve the desired temperature in a room quickly. By simultaneously detecting the humidity levels, the Smart Comfort Operation feature maintains the room's temperature automatically.



 **Fast Cooling**
↓



 **WindFree™ Cooling**

Motion Detect Sensor (optional)

The improved Motion Detect Sensor (MDS) detects the presence and location of people in the room, enabling automatic management of airflow direction and efficient air cooling.

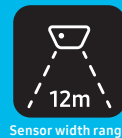
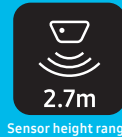

Auto Elevation Panel

The cleaning of filters is also an integral part of maintaining good indoor air quality, and elevation panels can make this process easier.

An Auto Elevation Panel is a panel that provides quick and comfortable access to dust filters for cleaning, facilitating extra convenience with the 4 metre¹ elevation advantage with a single remote click. Thus, a ladder is no longer required when cleaning panels. This makes it easier and safer for end users or service engineers to access filters for cleaning.

¹ May vary based on the actual usage conditions.



Not all features are available for all models.

Air Purification Panel

The Air Purification Panels in the WindFree™ 4-Way Cassette contain two types of filters to enhance the mitigation of certain Particulate Matter (PM), aimed to keep the indoor air cleaner all day long. The WindFree™ 4-Way Cassette is made of a two filter purification system the Pre-Filter and the PM1.0 Filter. The Pre-Filter captures larger dust particles, stopping them from entering the air conditioning unit.

The PM1.0 Filter¹ not only effectively captures ultrafine dust up to 0.3 µm but also inactivates certain types of bacteria that are captured, using an electrostatic precipitator. It has two main parts that charge and collect certain types of dust and bacteria¹. The brush discharger generates negative ions. And these give certain dust particles and bacteria¹ a negative charge, so they become strongly attached to the ground electrode due to the electrostatic force of the collector. An added advantage is that this filter is also semi washable, thus saving the purchase and maintenance cost of replacing the filter.



PM1.0 Filter



Pre-Filter

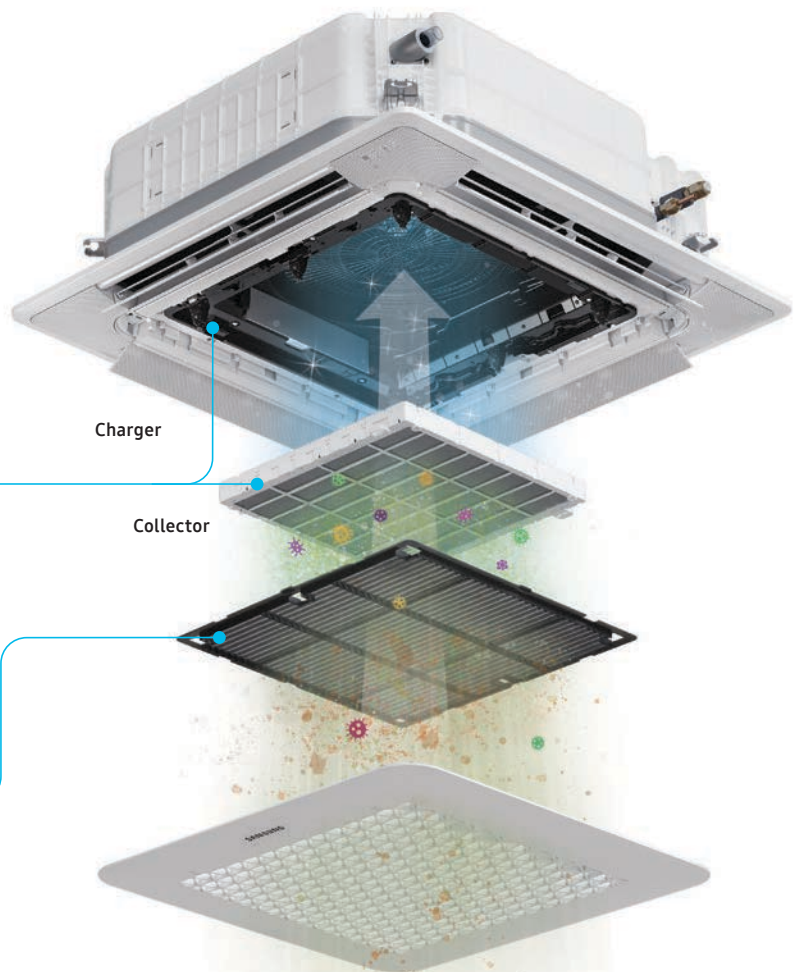

¹ Intertek Report No.: RT20E-S0010-R Date: APR. 17, 2020 (Revised) Based on the data collected the Hypothesis is accepted: The K-element (Electrostatic Precipitator) of Samsung Electronics can sterilize the certain types of bacteria that collected on the filter. (Escherichia coli : above 99 %, Staphylococcus aureus : above 99 %)

Detachable Washable Parts

The cleanliness of the exterior, as well as the filters, is very important for 4-Way Cassettes that are widely used in commercial spaces. The panels and filters of the WindFree™ 4-Way Cassette are very

easy to remove and clean. One can pull the hook inside the panel grille (near the Samsung logo) to open and remove it. And the corner panels and blades can be easily separated when pulled downwards. All of

the exterior parts can be cleaned with a soft brush or cloth. You can also use a vacuum or water to clean the internal filter, so you don't need to keep purchasing new filters.

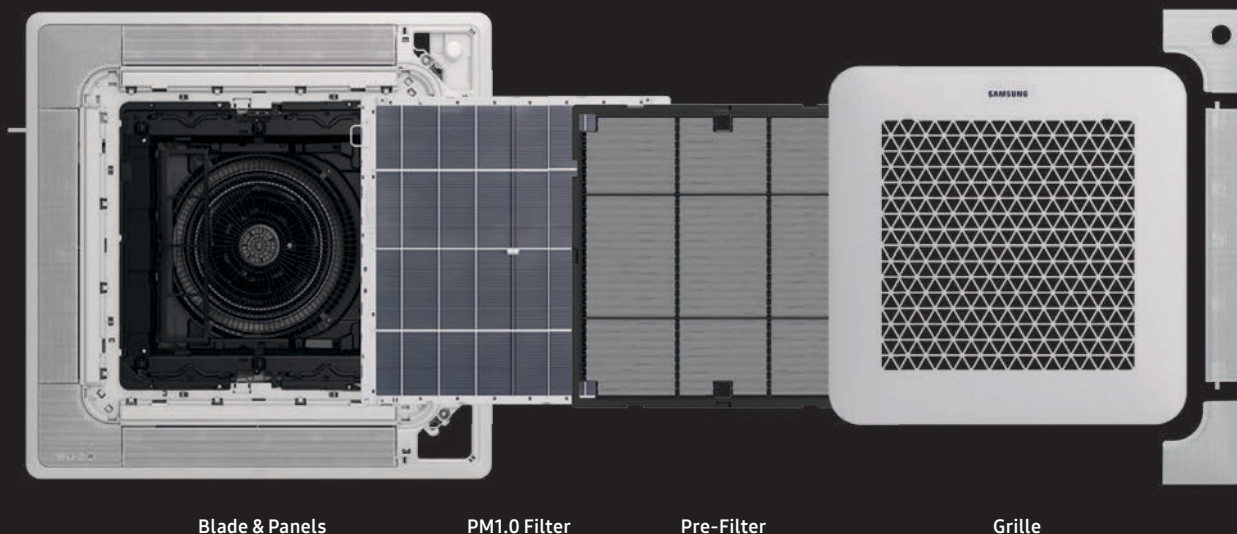

Blade & Panels

PM1.0 Filter

Pre-Filter

Grille

Self-Diagnosis

The WindFree™ 4-Way Cassette's Self-Diagnosis function alerts you to malfunctions straight away. It means that you can quickly arrange a service repair visit. And an error code and LED light enable engineers to easily identify the cause of any failure, helping to reduce the time it takes to diagnose and fix the problem.

Examples of relevant errors	LED-lamp display			
	On/Off	Defrost	Timer	Filter
Error on indoor temperature sensor		●		
Error on heat exchanger sensor of the indoor unit	●	●		
Error on outdoor unit sensors	●		●	
Error on MDS (Motion Detect Sensor)	●			●

● Blinking

Not all features are available for all models.

Specifications

Universal WindFree™ 4-Way 600 x 600 Cassette

- Fast Cooling mode and WindFree™ Cooling mode.
- Four-Way air supply via independently adjustable blades.
- Built-in condensation drain pump and humidity sensor.
- Direct drive fan powered by a BLDC motor.
- Can be controlled by SmartPhone via Smart panels.
- Built-in R32 refrigerant leak detect sensor.
- Motion Detect Sensor (Optional).
- Smart panels have built-in Single Wi-Fi Kit (MIM-H14EN).



Model			AM015DNNDKG/EU	AM022DNNDKG/EU	AM028DNNDKG/EU
Power Supply			Φ, #, V, Hz		
			1Φ, 2, 220-240 V, 50/60 Hz	1Φ, 2, 220-240 V, 50/60 Hz	1Φ, 2, 220-240 V, 50/60 Hz
Performance					
Capacity	Cooling	kW	1.5	2.2	2.8
	Heating	kW	1.7	2.5	3.2
Power					
Power Input	Cooling	W	18	18	18
	Heating	W	18	18	18
Current Input	Cooling	A	0.17	0.17	0.17
	Heating	A	0.17	0.17	0.17
Current	MCA	A	0.23	0.23	0.23
	MFA	A	15	15	15
Fan					
Type			Turbo Fan	Turbo Fan	Turbo Fan
Number of Fans	ea		1	1	1
Airflow Rate	H/M/L	m ³ /min	8.2/7.2/6.5	9.0/7.7/6.5	10.0/8.5/7.5
		L/s	142/120/108	150/128/108	167/142/125
Fan Motor					
Model			BLDC Motor	BLDC Motor	BLDC Motor
Output x n	W		65 x 1	65 x 1	65 x 1
Piping Connections					
Liquid Pipe	Ø, mm		6.35	6.35	6.35
	Ø, inch		1/4	1/4	1/4
Gas Pipe	Ø, mm		12.7	12.7	12.7
	Ø, inch		1/2	1/2	1/2
Drain Pipe	Ø, mm		VP25 (OD 32, ID 25)	VP25 (OD 32, ID 25)	VP25 (OD 32, ID 25)
Wiring Connections					
Communication	Min.	mm ²	0.75	0.75	0.75
	Remark	-	F1, F2	F1, F2	F1, F2
Refrigerant					
Type			R32(Fluorinated greenhouse gas, GWP=675)		
Electronic Expansion Valve			EEV INCLUDED	EEV INCLUDED	EEV INCLUDED
Sound					
Sound Pressure ¹	H/M/L	dB(A)	30/28/23	32/29/25	33/30/26
Sound Power	Cooling	dB(A)	46	47	50
Dimensions					
Net Weight	kg		11.5	11.6	11.6
Net Dimensions (W × H × D)	mm		575 x 250 x 575	575 x 250 x 575	575 x 250 x 575
Panel					
Model Name			PC4SUFMANW	PC4SUFMANW	PC4SUFMANW
Drain Pump					
Drain Pump			INCLUDED	INCLUDED	INCLUDED
Max. Lifting Height/Displacement	mm / litres/h		750/24	750/24	750/24

Controls



Wireless Remote Controller
AR-EH03E



Wireless Remote Controller
AR-CH01E



Simple Type Controller
MWR-SH00N



Touch Controller
MWR-SH11N



Wired Remote Controller
MWR-WG01*N



Wi-Fi Kit
MIM-H04EN

* Universal indoor units, universal controller and universal accessories can be installed both with DVM R410A and DVM R32 Outdoor units.

¹ Sound pressure level is obtained in an anechoic room. Sound pressure level is a relative value, depending on the distance and acoustic environment. Sound pressure level may differ depending on operation conditions.



AM036DNNDKG/EU	AM045DNNDKG/EU	AM056DNNDKG/EU	AM060DNNDKG/EU
1Φ, 2, 220-240 V, 50/60 Hz	1Φ, 2, 220-240 V, 50/60 Hz	1Φ, 2, 220-240 V, 50/60 Hz	1Φ, 2, 220-240 V, 50/60 Hz
3.6	4.5	5.6	6.0
4.0	5.0	6.3	6.8
20	23	28	31
20	23	28	31
0.19	0.22	0.27	0.30
0.19	0.22	0.27	0.30
0.25	0.29	0.35	0.39
15	15	15	15
Turbo Fan	Turbo Fan	Turbo Fan	Turbo Fan
1	1	1	1
10.5/9.0/7.5	11.5/10.2/9.0	13.0/11.0/9.5	13.5/12.0/10.2
175/150/125	192/170/150	217/183/158	225/200/170
BLDC Motor	BLDC Motor	BLDC Motor	BLDC Motor
65 x 1	65 x 1	65 x 1	65 x 1
6.35	6.35	6.35	6.35
1/4	1/4	1/4	1/4
12.7	12.7	12.7	12.7
1/2	1/2	1/2	1/2
VP25 (OD 32, ID 25)	VP25 (OD 32, ID 25)	VP25 (OD 32, ID 25)	VP25 (OD 32, ID 25)
0.75	0.75	0.75	0.75
F1, F2	F1, F2	F1, F2	F1, F2
R32(Fluorinated greenhouse gas, GWP=675)			
EEV INCLUDED	EEV INCLUDED	EEV INCLUDED	EEV INCLUDED
34/30/26	36/34/32	39/36/33	40/38/35
51	53	56	57
11.6	12	12	12
575 x 250 x 575	575 x 250 x 575	575 x 250 x 575	575 x 250 x 575
PC4SUFMANW	PC4SUFMANW	PC4SUFMANW	PC4SUFMANW
INCLUDED	INCLUDED	INCLUDED	INCLUDED
750/24	750/24	750/24	750/24

Accessories



External Room Sensor

Panel (Mandatory)

Motion Detect Sensor

MRW-TA

PC4SUFMANW

MCR-SMD

Specifications

Universal Sensible WindFree™ 4-Way Cassette

- Fast Cooling mode and WindFree™ Cooling mode.
- Four-Way air supply via independently adjustable blades.
- Built-in condensation drain pump and humidity sensor.
- Direct drive fan powered by a BLDC motor.
- Built-in R32 refrigerant leak detect sensor.
- Can be controlled by SmartPhone via Smart panels.
- Motion Detect Sensor (Optional).
- Air Purification Panel, Auto Elevation Panel (Optional).
- Smart panels have built-in Single Wi-Fi Kit (MIM-H14EN).



Model			AM022DN4FKG/EU	AM028DN4FKG/EU	AM036DN4FKG/EU
Power Supply		Φ, #, V, Hz	1Φ, 2, 220–240 V, 50/60 Hz	1Φ, 2, 220–240 V, 50/60 Hz	1Φ, 2, 220–240 V, 50/60 Hz
Performance					
Capacity	Cooling	kW	2.2	2.8	3.6
	Heating	kW	2.5	3.2	4.0
Power					
Power Input	Cooling	W	17	20	27
	Heating	W	17	20	27
Current Input	Cooling	A	0.14	0.17	0.23
	Heating	A	0.14	0.17	0.23
Current	MCA	A	0.29	0.33	0.41
	MFA	A	15	15	15
Fan					
Type	-		Turbo Fan	Turbo Fan	Turbo Fan
Number of Fans	-		1	1	1
Airflow Rate		m ³ /min	13.0/12.0/11.0	14.0/13.0/12.0	16.0/15.0/14.0
		L/s	217/200/183	233/217/200	267/250/233
Fan Motor					
Model	-		BLDC Motor	BLDC Motor	BLDC Motor
Output x n	W		65 x 1	65 x 1	65 x 1
Piping Connections					
Liquid Pipe		Ø, mm	6.35	6.35	6.35
		Ø, inch	1/4	1/4	1/4
Gas Pipe		Ø, mm	12.70	12.70	12.70
		Ø, inch	1/2	1/2	1/2
Drain Pipe		Ø, mm	VP25 (OD 32,ID 25)	VP25 (OD 32,ID 25)	VP25 (OD 32,ID 25)
Wiring Connections					
Communication	Minimum	mm ²	0.75	0.75	0.75
	Remark	-	F1, F2	F1, F2	F1, F2
Refrigerant					
Type	-		R32(Fluorinated greenhouse gas, GWP=675)		
Electronic Expansion Valve	-		EEV INCLUDED	EEV INCLUDED	EEV INCLUDED
Sound					
Sound Pressure ¹	H/M/L/W	dB(A)	32/30/29/29	33/31/30/30	34/33/31/31
Sound Power	Cooling	dB(A)	48	49	50
Dimensions					
Net Weight		kg	18	18	18
Net Dimensions (W × H × D)		mm	840 x 246 x 840	840 x 246 x 840	840 x 246 x 840
Panel					
Model Name	-		PC4NUFMANW PC4NBFMANW PC4NUCMANW PC4NUXMANW	PC4NUFMANW PC4NBFMANW PC4NUCMANW PC4NUXMANW	PC4NUFMANW PC4NBFMANW PC4NUCMANW PC4NUXMANW
Drain Pump					
Drain Pump	-		INCLUDED	INCLUDED	INCLUDED
Max. Lifting Height/Displacement		mm / litres/h	750 / 24	750 / 24	750 / 24

* Universal indoor units, universal controller and universal accessories can be installed both with DVM R410A and DVM R32 Outdoor units.

¹ Sound pressure level is obtained in an anechoic room. Sound pressure level is a relative value, depending on the distance and acoustic environment. Sound pressure level may differ depending on operation conditions.



AM045DN4FKG/EU	AM056DN4FKG/EU	AM071DN4FKG/EU
1Φ, 2, 220-240 V, 50/60 Hz	1Φ, 2, 220-240 V, 50/60 Hz	1Φ, 2, 220-240 V, 50/60 Hz
4.5	5.6	7.1
5.0	6.3	8.0
35	49	75
35	49	75
0.29	0.38	0.58
0.29	0.38	0.58
0.49	0.57	0.56
15	15	15
Turbo Fan	Turbo Fan	Turbo Fan
1	1	1
18.0/16.0/14.0	24.0/21.0/19.0	31.0/26.0/21.0
300/267/233	400/350/317	517/433/350
BLDC Motor	BLDC Motor	BLDC Motor
65 x 1	97 x 1	97 x 1
6.35	6.35	9.52
1/4	1/4	3/8
12.70	12.70	15.88
1/2	1/2	5/8
VP25 (OD 32, ID 25)	VP25 (OD 32, ID 25)	VP25 (OD 32, ID 25)
0.75	0.75	0.75
F1, F2	F1, F2	F1, F2
R32(Fluorinated greenhouse gas, GWP=675)		
EEV INCLUDED	EEV INCLUDED	EEV INCLUDED
34/32/30/30	35/33/29/29	39/36/32/32
50	51	55
18	21.5	22.5
840 x 246 x 840	840 x 288 x 840	840 x 288 x 840
PC4NUFMANW PC4NBFMANW PC4NUCMANW PC4NUXMANW	PC4NUFMANW PC4NBFMANW PC4NUCMANW PC4NUXMANW	PC4NUFMANW PC4NBFMANW PC4NUCMANW PC4NUXMANW
INCLUDED	INCLUDED	INCLUDED
750/24	750/24	750/24

Controls

Wireless Remote Controller	Wireless Remote Controller	Simple Type Controller
AR-EH03E	AR-CH01E	MWR-SH00N
Touch Controller	Wired Remote Controller	Wi-Fi Kit
MWR-SH11N	MWR-WG01*N	MIM-H04EN

Accessories

External Room Sensor	Panel Black (Mandatory)	Panel White (Mandatory)
MRW-TA	PC4NBFMANW	PC4NUFMANW
Air Purification Panel (Optional)	Auto Elevation Panel (Optional)	Motion Detect Sensor
PC4NUCMANW	PC4NUXMANW	MCR-SMC

Specifications

Universal WindFree™ 4-Way Cassette

- Fast Cooling mode and WindFree™ Cooling mode.
- Four-Way air supply via independently adjustable blades.
- Built-in condensation drain pump and humidity sensor.
- Direct drive fan powered by a BLDC motor.
- Built-in R32 refrigerant leak detect sensor.
- Can be controlled by SmartPhone via Smart panels.
- Motion Detect Sensor (Optional).
- Air Purification Panel, Auto Elevation Panel (Optional).
- Smart panels have built-in Single Wi-Fi Kit (MIM-H14EN)



Model			AM028DN4DKG/EU	AM036DN4DKG/EU	AM045DN4DKG/EU
Power Supply			Φ, #, V, Hz		
Performance			1Φ, 2, 220-240 V, 50/60 Hz	1Φ, 2, 220-240 V, 50/60 Hz	1Φ, 2, 220-240 V, 50/60 Hz
Capacity					
	Cooling	kW	2.8	3.6	4.5
	Heating	kW	3.2	4.0	5.0
Power					
Power Input					
	Cooling	W	24	26	28
	Heating	W	24	26	28
Current Input					
	Cooling	A	0.25	0.27	0.30
	Heating	A	0.25	0.27	0.30
Current					
	MCA	A	0.33	0.36	0.4
	MFA	A	15	15	15
Fan					
Type			Turbo Fan	Turbo Fan	Turbo Fan
Number of Fans			1	1	1
Airflow Rate					
	H/M/L	m ³ /min	14.4/13.4/12.4	15.4/14.4/13.4	16.3/15.4/14.4
	H/M/L	L/s	240/223.3/206.7	255/240/223.3	271.7/256.7/240
Fan Motor					
Model			BLDC Motor	BLDC Motor	BLDC Motor
Output x n			65 x 1	65 x 1	65 x 1
Piping Connections					
Liquid Pipe					
		Ø, mm	6.35	6.35	6.35
		Ø, inch	1/4	1/4	1/4
Gas Pipe					
		Ø, mm	12.70	12.70	12.70
		Ø, inch	1/2	1/2	1/2
Drain Pipe			VP25 (OD 32, ID 25)	VP25 (OD 32, ID 25)	VP25 (OD 32, ID 25)
Wiring Connections					
Communication					
	Minimum	mm ²	0.75	0.75	0.75
	Remark	-	F1, F2	F1, F2	F1, F2
Refrigerant					
Type			R32(Fluorinated greenhouse gas, GWP=675)		
Electronic Expansion Valve			EEV INCLUDED	EEV INCLUDED	EEV INCLUDED
Sound					
Sound Pressure ¹					
	H/M/L/W	dB(A)	30/28/27/27	31/30/28/28	33/31/29/29
Sound Power					
	Cooling	dB(A)	46	47	49
Dimensions					
Net Weight			15.0	15.0	15.0
Net Dimensions (W × H × D)			840 x 204 x 840	840 x 204 x 840	840 x 204 x 840
Panel					
Model Name			PC4NUFMANW PC4NBFMANW PC4NUCMANW PC4NUXMANW	PC4NUFMANW PC4NBFMANW PC4NUCMANW PC4NUXMANW	PC4NUFMANW PC4NBFMANW PC4NUCMANW PC4NUXMANW
Drain Pump					
Drain Pump			INCLUDED	INCLUDED	INCLUDED
Max. Lifting Height/Displacement			750 / 24	750 / 24	750/24

Controls



Wireless Remote Controller	Wireless Remote Controller	Simple Type Controller	Touch Controller	Wired Remote Controller	Wi-Fi Kit
AR-EH03E	AR-CH01E	MWR-SH00N	MWR-SH11N	MWR-WG01*N	MIM-H04EN

* Universal indoor units, universal controller and universal accessories can be installed both with DVM R410A and DVM R32 Outdoor units.

¹ Sound pressure level is obtained in an anechoic room. Sound pressure level is a relative value, depending on the distance and acoustic environment. Sound pressure level may differ depending on operation conditions.



AM056DN4DKG/EU	AM071DN4DKG/EU	AM090DN4DKG/EU	AM112DN4DKG/EU	AM128DN4DKG/EU	AM140DN4DKG/EU
1Φ, 2, 220-240 V, 50/60 Hz	1Φ, 2, 220-240 V, 50/60 Hz	1Φ, 2, 220-240 V, 50/60 Hz	1Φ, 2, 220-240 V, 50/60 Hz	1Φ, 2, 220-240 V, 50/60 Hz	1Φ, 2, 220-240 V, 50/60 Hz
5.6	7.1	9.0	11.2	12.8	14.0
6.3	8.0	10.0	12.5	13.8	16.0
32	34	55	78	95	115
32	34	55	78	95	115
0.32	0.35	0.45	0.60	0.75	0.85
0.32	0.35	0.45	0.60	0.75	0.85
0.43	0.47	0.6	0.8	1.0	1.13
15	15	15	15	15	15
Turbo Fan	Turbo Fan	Turbo Fan	Turbo Fan	Turbo Fan	Turbo Fan
1	1	1	1	1	1
16.4/14.6/12.8	18.2/15.4/12.8	24.4/19.9/15.5	26.6/21.0/15.5	35.4/29.2/24.3	37.9/31.7/25.5
273/243.3/213.3	303.3/256.7/213.3	406.7/331.7/258.3	443.3/350/258.3	590/486.7/405	631.7/528.3/425
BLDC Motor	BLDC Motor	BLDC Motor	BLDC Motor	BLDC Motor	BLDC Motor
65 x 1	65 x 1	65 x 1	65 x 1	97 x 1	97 x 1
6.35	9.52	9.52	9.52	9.52	9.52
1/4	3/8	3/8	3/8	3/8	3/8
12.70	15.88	15.88	15.88	15.88	15.88
1/2	5/8	5/8	5/8	5/8	5/8
VP25 (OD 32, ID 25)	VP25 (OD 32, ID 25)	VP25 (OD 32, ID 25)	VP25 (OD 32, ID 25)	VP25 (OD 32, ID 25)	VP25 (OD 32, ID 25)
0.75	0.75	0.75	0.75	0.75	0.75
F1, F2	F1, F2	F1, F2	F1, F2	F1, F2	F1, F2
R32(Fluorinated greenhouse gas, GWP=675)					
EEV INCLUDED	EEV INCLUDED	EEV INCLUDED	EEV INCLUDED	EEV INCLUDED	EEV INCLUDED
35/33/29/29	37/34/30/30	39/35/30/30	41/36/30/30	42/37/35/35	44/39/35/35
51	53	55	59	58	60
16.5	16.5	18.0	19.0	21.5	22.5
840 x 204 x 840	840 x 204 x 840	840 x 246 x 840	840 x 246 x 840	840 x 288 x 840	840 x 288 x 840
PC4NUFMANW PC4NBFMANW PC4NUCMANW PC4NUXMANW	PC4NUFMANW PC4NBFMANW PC4NUCMANW PC4NUXMANW	PC4NUFMANW PC4NBFMANW PC4NUCMANW PC4NUXMANW	PC4NUFMANW PC4NBFMANW PC4NUCMANW PC4NUXMANW	PC4NUFMANW PC4NBFMANW PC4NUCMANW PC4NUXMANW	PC4NUFMANW PC4NBFMANW PC4NUCMANW PC4NUXMANW
INCLUDED	INCLUDED	INCLUDED	INCLUDED	INCLUDED	INCLUDED
750/24	750/24	750/24	750/24	750/24	750/24

Accessories



External Room Sensor	Panel Black (Mandatory)	Panel White (Mandatory)	Air Purification Panel (Optional)	Auto Elevation Panel (Optional)	Motion Detect Sensor
MRW-TA	PC4NBFMANW	PC4NUFMANW	PC4NUCMANW	PC4NUXMANW	MCR-SMC

WindFree™ 1-Way Cassette

UNIQUE

Slim installation

At a height of only 135 mm¹, the WindFree™ 1-Way Cassette is a compact and lightweight device (8–13.5 kg). This slim design makes it not only visually pleasing but also easier to install and maintain, and it can be fitted into small gaps or ceilings.



Easy Maintenance

The Samsung WindFree™ 1-Way Cassette requires no duct work. You simply need to regularly clean the built-in filter with water, after removing it from your air conditioner.

Ducted Airconditioner

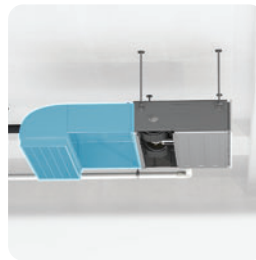

Duct work required
Dust particles accumulate in both filters and duct work



Professional cleaning service or tool required
It is difficult to clean the inside duct work, so you need to hire a professional cleaner

WindFree™ 1-Way Cassette



No duct work required
Only the filter needs to be cleaned



Anyone can clean it with water
Only the filter needs to be cleaned

¹ 135 mm is the height of the unit until the ceiling tile. 145 mm is the height including the ceiling tile. Up to 3.6 kW (DVM) models measures 135 mm (180 mm including panel).



Wider cooling range

The larger optimised blade is 100 mm¹ and works to cool a larger area much faster. Its sleek design can deliver cool air efficiently, rapidly and evenly over an area of up to 8 m² leaving no zone untouched.

¹ Samsung testing compares the WindFree™ 1-Way Cassette to a conventional 1-Way Cassette-type air conditioner.
² Based on the 7.1 kW indoor unit.

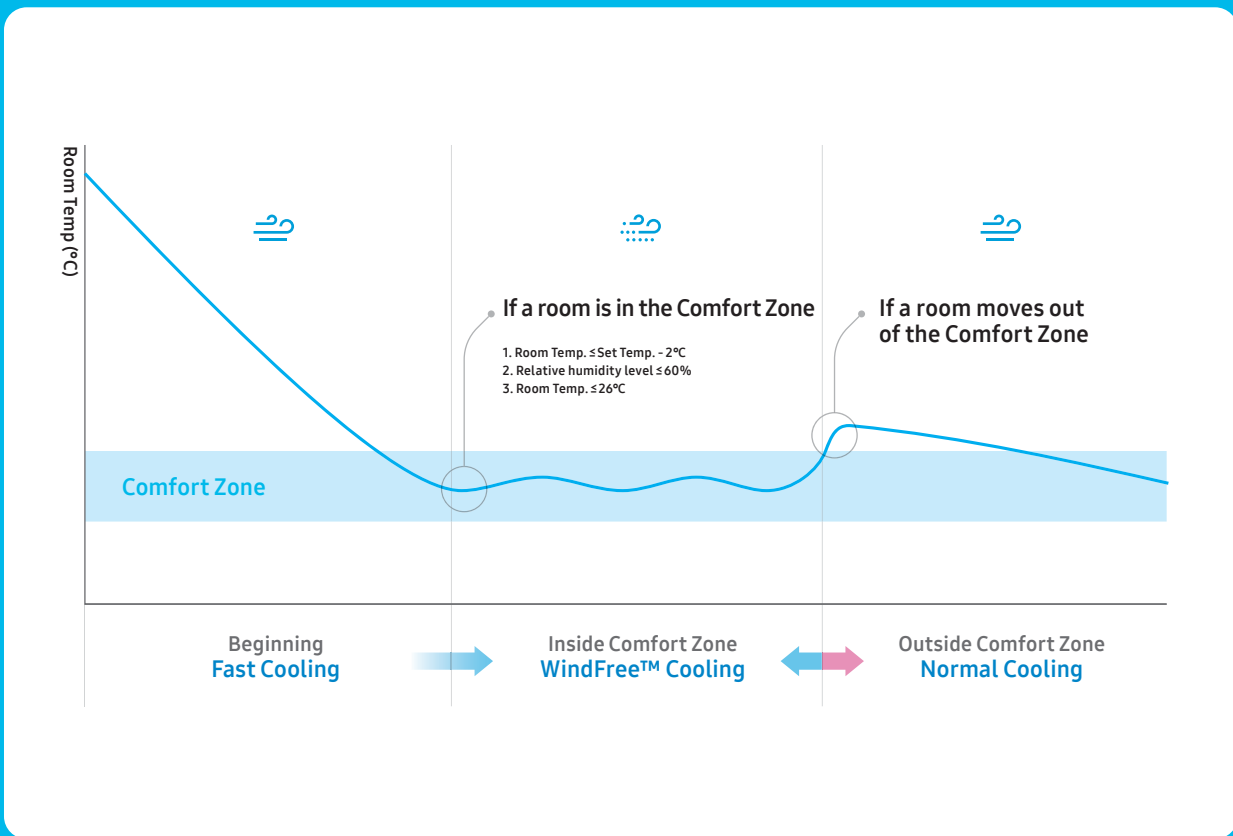

Smart Comfort Operation

The WindFree™ 1-Way Cassette has a humidity sensor as well as a temperature sensor. It continually monitors both the temperature and relative humidity¹ and analyzes the room

conditions. It then automatically switches between operating modes to keep everyone feeling really comfortable without the need for any manual control.

¹ The humidity level will only be shown during WindFree™ operation and Dry Mode via the SmartThings app display.

Not all features are available for all models.

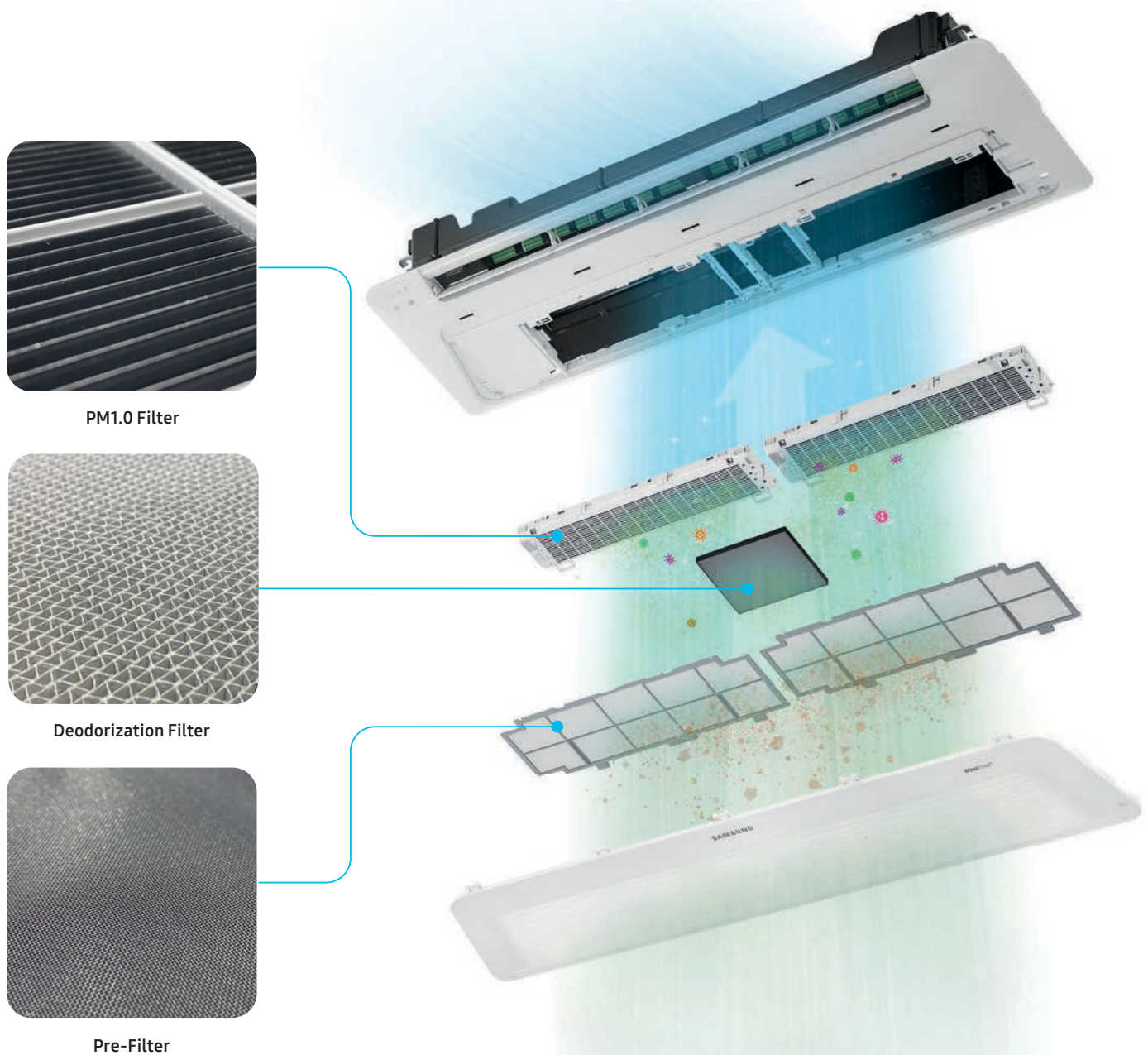

PM1.0 Filter

Deodorization Filter

Pre-Filter

Air Purification Panel

The Air Purification Panels in the WindFree™ 1-Way Cassette contain three types of filters to enhance the mitigation of certain Particulate Matter, aimed to keep the indoor air cleaner all day long. The WindFree™ 1-Way Cassette is made of a three filter purification system the Pre-Filter, Deodorization Filter¹ and the PM1.0 Filter.

The Pre-Filter captures larger dust particles, stopping them from entering the air conditioning unit. The deodorization filter captures certain unpleasant odours. The PM1.0 Filter not only effectively

captures ultrafine dust upto 0.3 µm but also inactivates certain types of bacteria that are captured, using an electrostatic precipitator. It has two main parts that charge and collect certain types of dust and bacteria.² The brush discharger generates negative ions. These give the dust particles and certain types of bacteria a negative charge, so they become strongly attached to the ground electrode due to the electrostatic force of the collector. An added advantage is that this filter is also semi washable, thus saving the purchase and maintenance cost of replacing the filter.

¹ The Deodorization Filter can only be found in WindFree™ 1-Way Cassette.

² Intertek Report No.: RT20E-S0010-R Date: APR. 17, 2020 (Revised) Based on the data collected the Hypothesis is accepted: The K-element (Electrostatic Precipitator) of Samsung Electronics can sterilize the certain types of bacteria that collected on the filter. (Escherichia coli: above 99 %, Staphylococcus aureus: above 99 %)

13,000 micro-holes

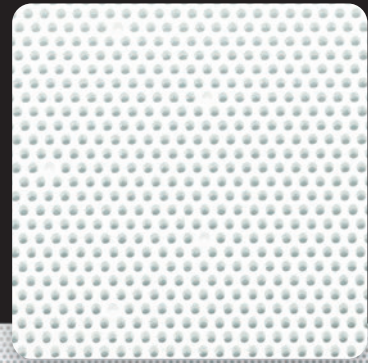

WindFree™ Technology

The WindFree™ 1-Way Cassette uses WindFree™ Cooling and directs air through tiny holes in the panel, dispersing a gentle flow of air. These 13,000 micro-holes are essential for creating a type of airflow called “Still Air”¹, which cools the room gradually and noticeably without drafts.

¹ ASHRAE (the American Society of Heating, Refrigeration, and Air-Conditioning Engineers) defines “Still Air” as air currents moving at speeds below 0.15 m/s, with no cold drafts.

Specifications

Universal WindFree™ 1-Way Cassette

- Fast Cooling mode and WindFree™ Cooling mode.
- One-Way air supply by means of a 100 mm wide blade.
- Built-in condensation drain pump and humidity sensor.
- Cross-flow fan direct driven by a BLDC motor.
- Built-in R32 refrigerant leak detect sensor.
- Optional Air Purification Panel.
- Can be controlled by SmartPhone via Smart panels.
- Smart panels have built-in Single Wi-Fi Kit (MIM-H14EN).



Model			AM017DN1DKG/EU	AM022DN1DKG/EU	AM028DN1DKG/EU
Power Supply			1Φ, 2, 220–240 V, 50/60 Hz		
Performance					
Capacity	Cooling	kW	1.7	2.2	2.8
	Heating	kW	1.9	2.5	3.2
Power					
Power Input	Cooling	W	24	25	50
	Heating	w	24	25	50
Current Input	Cooling	A	0.14	0.15	0.23
	Heating	A	0.14	0.15	0.23
Current	MCA	A	0.18	0.18	0.29
	MFA	A	15	15	15
Fan					
Type	-	-	Crossflow Fan	Crossflow Fan	Crossflow Fan
Number of Fans	-	ea	1	1	1
Airflow Rate	H/M/L	m ³ /min	4.80/4.30/4.10	5.10/4.60/4.30	7.00/6.00/5.00
		l/s	80.00/71.67/68.33	85.00/76.67/71.67	116.67/100.00/83.33
Fan Motor					
Model	-	-	BLDC Motor	BLDC Motor	AC Motor
Output x n	-	W	27 x 1	27 x 1	23 x 1
Piping Connections					
Liquid Pipe	Ø, mm	Ø, mm	6.35	6.35	6.35
		Ø, inch	1/4	1/4	1/4
Gas Pipe	Ø, mm	Ø, mm	12.70	12.70	12.70
		Ø, inch	1/2	1/2	1/2
Drain Pipe	Ø, mm	-	VP20 (OD 25, ID 20)	VP20 (OD 25, ID 20)	VP20 (OD 25, ID 20)
Wiring Connections					
Connection with Indoor	Minimum	mm ²	0.75	0.75	0.75
	Remark	-	F1, F2	F1, F2	F1, F2
Refrigerant					
Type	-	-	R32(Fluorinated greenhouse gas, GWP=675)		
Electronic Expansion Valve	-	-	EEV INCLUDED	EEV INCLUDED	EEV INCLUDED
Sound					
Sound Pressure ¹	(H/M/L)	dB(A)	28/26/24	29/26/24	32/28/24
Sound Power	Cooling	dB(A)	46	47	50
Dimension					
Net Weight	-	kg	8.0	8.0	10.0
Net Dimensions (W x H x D)	-	mm	740 x 135 x 360	740 x 135 x 360	970 x 135 x 410
Panel					
Model Name	-	-	PC1MWFMANW PC1MWCMANW	PC1MWFMANW PC1MWCMANW	PC1NWFMANW PC1NWCANW
Drain pump					
Max. Lifting Height/Displacement	-	mm / litres/h	INCLUDED 750/24	INCLUDED 750/24	INCLUDED 750/24

¹ Sound pressure level is obtained in an anechoic room. Sound pressure level is a relative value, depending on the distance and acoustic environment. Sound pressure level may differ depending on operation conditions.



AM036DN1DKG/EU	AM056DN1DKG/EU	AM071DN1DKG/EU
1Φ, 2, 220-240 V, 50/60 Hz	1Φ, 2, 220-240 V, 50/60 Hz	1Φ, 2, 220-240 V, 50/60 Hz
3.6	5.6	7.1
4.0	6.3	8.0
50	55	80
50	55	80
0.25	0.28	0.40
0.25	0.28	0.40
0.31	0.35	0.5
15	15	15
Crossflow Fan	Crossflow Fan	Crossflow Fan
1	1	1
8.00/7.00/6.00	16.00/14.00/12.50	17.00/15.50/14.00
133.33/116.67/100.00	266.67/233.33/208.33	283.33/258.33/233.33
AC Motor	BLDC Motor	BLDC Motor
23 x 1	54 x 1	54 x 1
6.35	6.35	9.52
1/4	1/4	3/8
12.70	12.70	15.88
1/2	1/2	5/8
VP20 (OD 25, ID 20)	VP20 (OD 25, ID 20)	VP20 (OD 25, ID 20)
0.75	0.75	0.75
F1, F2	F1, F2	F1, F2
R32(Fluorinated greenhouse gas, GWP=675)		
EEV INCLUDED	EEV INCLUDED	EEV INCLUDED
37/33/30	41/38/35	42/39/36
55	59	60
10.0	13.5	13.5
970 x 135 x 410	1,200 x 138 x 450	1,200 x 138 x 450
PC1NWFMANW PC1NWCMANW	PC1BWFMANW PC1BWCMANW	PC1BWFMANW PC1BWCMANW
INCLUDED	INCLUDED	INCLUDED
750/24	750/24	750/24

Controls

Wireless Remote Controller	Wireless Remote Controller	Simple Type Controller
AR-EH03E	AR-CH01E	MWR-SH00N
Touch Controller	Wired Remote Controller	Wi-Fi Kit
MWR-SH11N	MWR-WG01*N	MIM-H04EN

Accessories

External Room Sensor	Panel (Mandatory)	Air Purification Panel (Optional)
MRW-TA	PC1MWFMANW PC1NWFMANW PC1BWFMANW	PC1MWCMANW PC1NWCMANW PC1BWCMANW

360 cassette



Airflow Control

The air supply is easily adjusted without the use of flaps. Three booster fans work to alter the direction of airflow from within the cassette's hollow space. A rain-like distribution of the air (known as the 'coanda' effect) keeps the room cool and comfortable at all times. The innovative technology overcomes the usual limits of the conventional outlets that use blades, as they obstruct the air at low angles and cause a significant low airflow¹. The Motion Detector Sensor (MDS) is available for the 360 Cassette.

¹ Based on internal testing compared to a general 4-Way Cassette air conditioner.

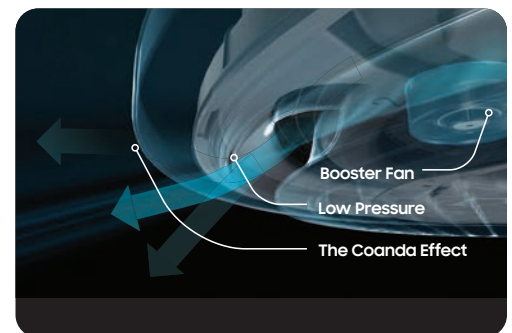

Stylish design

The 360 Cassette has an innovative circular design that enables it to match a multitude of interior designs, that adds a touch of style to any room. Its minimalistic and elegant styling can help to create a sophisticated and distinctive look in many different sites. With a circular panel, it can fit into a very tiny ceiling space of just 225 mm¹, so it gives you much greater flexibility as it can be installed in a wider choice of locations. The 360 Cassette is available in black or white, in a square or circular design, and can be fitted within the ceiling or exposed on any material.

¹ The minimum installation height of ceiling space may vary depending on the panel design - circular or square type. Square type panels require 30 mm more height in a ceiling space than circular type panel.

Circular LED display

The unit features a stylish panel and an intuitive Circular LED display, which allows users to choose or adjust the direction of the airflow with an intuitive wireless (jog shuttle) wireless remote controller. Besides the LED Display also monitors other essential operating information, such as the filter the air flow direction, filter status and any errors. So, with just one glance, you can quickly tell where the air is going and how your 360 Cassette is performing.

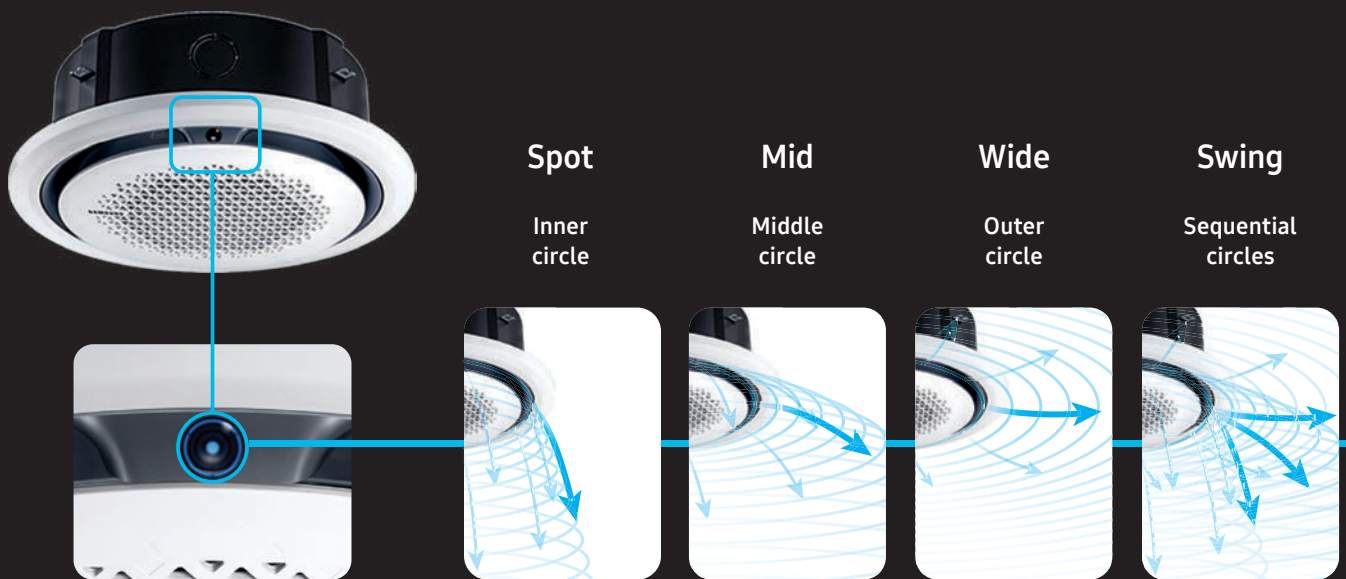

Samsung 360 Cassette

Circular airflow

Unlike traditional 4-Way Cassette units¹, which create areas of uneven airflow², the 360 Cassette reaches every single corner of a room or space. Its circular outlet blows cool air in every direction. The bladeless design keeps things comfortably cool without creating a cold draft³, and without blades blocking the airflow it sends 25 % more air even further¹.

¹ Samsung testing compares the 360 Cassette to a conventional 4-Way Cassette type air conditioner.

² The temperature difference is less than 0.6°C within a 9.3 m radius.

³ No cold draft between 0–1.5 m in height (with a 14.0 kW indoor unit) within a 5 m radius.

Conventional
4-Way Cassette

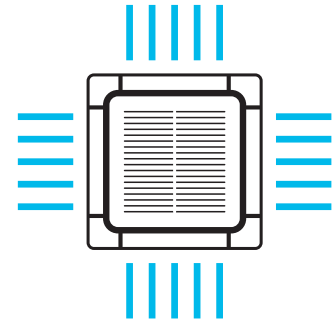
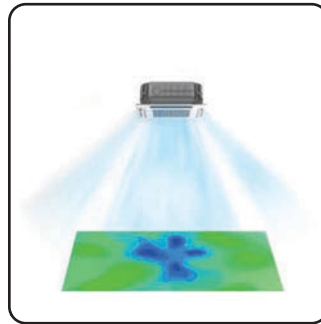

Samsung
360 Cassette

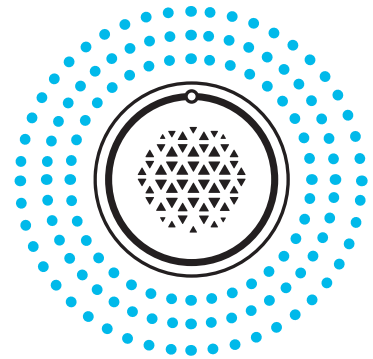
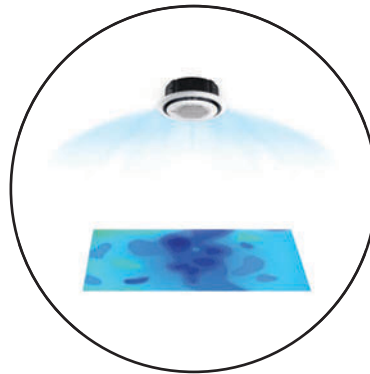

Operating

Ice Blue dot

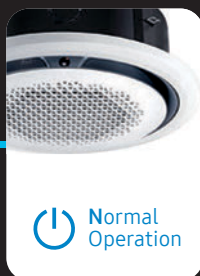

Filter

Yellow Green dot

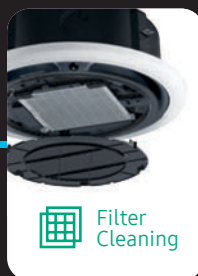

Error

Blue dot
(blinking)



Error

Red dot
(blinking)



360 Cassette

Air Purification Panel

The Samsung 360 Cassette offers an Purifying Panel that keeps the indoor air cleaner. It is made of a two filter purification system the pre-filter and the PM1.0 Filter and has a superior filter mesh with 0.5 mm holes, which is 20 % denser than a vinyl chloride type filter.

The Pre-Filter captures larger dust particles, stopping them from entering the air conditioning unit. The PM1.0 Filter is not only effective at capturing ultrafine dust of up to 0.3 µm in size, but it also sterilizes up to 99 % of certain types of bacteria¹ trapped by the filter using an electrostatic precipitator¹.

¹ Verified by Intertek, Report Number RT20E-S0010-R, Issue Date: 17 April 2020. The K-element (Electrostatic Precipitator) of Samsung Electronics can sterilize certain types of bacteria that collected on the filter (Escherichia coli: above 99 %, Staphylococcus aureus: above 99 %).

² The Air Purification panel is an optional accessory.

Air Purity Level Display



Auto Elevation Panel

The cleaning of filters is also an integral part of maintaining good indoor air quality, and elevation panels can make this process easier.

An Auto Elevation Panel is a panel that provides quick and comfortable access to dust filters for cleaning, facilitating extra convenience with the 4.5 metre¹ elevation advantage with a single remote click. Thus, a ladder is no longer required when cleaning panels. This makes it easier and safer for end users or service engineers to access filters for cleaning.

¹ May vary based on the actual usage conditions.

² The Auto Elevation panel is an optional accessory.





Specifications

Universal 360 Cassette

- 360 degree air supply.
- Bladeless discharge. Booster fans can be individually controlled, allowing for completely horizontal flow discharge. Coandă effect is created even without ceiling.
- Built-in condensation drain pump and R32 refrigerant leak detect sensor.
- The Air purification panel is an optional accessory for circle panel.
- Auto elevation panel is an optional accessory available in circle panel
- Circular or square cassette panel. Available in white and black.
- Predisposition of the air inlet to let fresh air in.
- Can be controlled by SmartPhone via Smart panels.
- Motion Detector Sensor is optional for square cassette panel.
- Smart panels have built-in Single Wi-Fi Kit (MIM-H14EN).



Model			AM045DN6DKG/EU	AM056DN6DKG/EU	AM071DN6DKG/EU
Power Supply		Φ, #, V, Hz	1Φ, 2, 220–240 V, 50/60 Hz	1Φ, 2, 220–240 V, 50/60 Hz	1Φ, 2, 220–240 V, 50/60 Hz
Performance					
Capacity (Nominal)	Cooling	kW	4.5	5.6	7.1
	Heating	kW	5.0	6.3	8.0
Power					
Power Input (Nominal)	Cooling	W	26	30	34
	Heating	W	26	30	34
Current Input (Nominal)	Cooling	A	0.18	0.21	0.25
	Heating	A	0.18	0.21	0.25
Fan					
Motor	Type	-	Turbo Fan	Turbo Fan	Turbo Fan
	Output x n	w	65 x 1	65 x 1	65 x 1
Airflow Rate	H/M/L (UL)	m ³ /min	14.50/13.50/12.50	16.00/14.50/13.50	18.00/16.00/14.00
		l/s	242/225.00/208	267/242/225	300.00/267/233
Piping Connections					
Liquid Pipe		Ø, mm	6.35	6.35	9.52
		Ø, inch	1/4	1/4	3/8
Gas Pipe		Ø, mm	12.70	12.70	15.88
		Ø, inch	1/2	1/2	5/8
Drain Pipe		Ø, mm	VP25 (OD 32, ID 25)	VP25 (OD 32, ID 25)	VP25 (OD 32, ID 25)
Field Wiring					
Power Source Wire		mm ²	1.5–2.5	1.5–2.5	1.5–2.5
Transmission Cable		mm ²	0.75–1.50	0.75–1.50	0.75–1.50
Refrigerant					
Type		-	R32(Fluorinated greenhouse gas, GWP=675)		
Control Method		-	EEV INCLUDED	EEV INCLUDED	EEV INCLUDED
Sound					
Sound Pressure ¹	(H/M/L)	dB(A)	33/31/29	34/32/29	36/33/30
Sound Power	Cooling	dB(A)	50	51	53
Dimension					
Net Weight		kg	21	21	21
Net Dimensions (W x H x D)		mm	947 x 281 x 947	947 x 281 x 947	947 x 281 x 947
Model Name		-	PC6NUSMANW PC6EUSMANW PC6NBSMANW PC6EBSMANW PC6EUCMANW PC6EUXMANW	PC6NUSMANW PC6EUSMANW PC6NBSMANW PC6EBSMANW PC6EUCMANW PC6EUXMANW	PC6NUSMANW PC6EUSMANW PC6NBSMANW PC6EBSMANW PC6EUCMANW PC6EUXMANW

Controls



Wireless Remote Controller	Simple Type Controller	Touch Controller	Wired Remote Controller	Wi-Fi Kit
AR-CHOIE	MWR-SH00N	MWR-SH11N	MWR-WG01*N	MIM-H04EN

* Universal indoor units, universal controller and universal accessories can be installed both with DVM R410A and DVM R32 Outdoor units.
¹ Sound pressure level is obtained in an anechoic room. Sound pressure level is a relative value, depending on the distance and acoustic environment. Sound pressure level may differ depending on operation conditions.



AM090DN6DKG/EU	AM112DN6DKG/EU	AM128DN6DKG/EU	AM140DN6DKG/EU
1Φ, 2, 220-240 V, 50/60 Hz	1Φ, 2, 220-240 V, 50/60 Hz	1Φ, 2, 220-240 V, 50/60 Hz	1Φ, 2, 220-240 V, 50/60 Hz
9.0	11.2	12.8	14.0
10.0	12.5	13.8	16.0
55	53	77	91
55	53	77	91
0.42	0.41	0.62	0.75
0.42	0.41	0.62	0.75
Turbo Fan	Turbo Fan	Turbo Fan	Turbo Fan
65 x 1	97 x 1	97 x 1	97 x 1
22.00/18.50/16.00	25.50/21.00/17.50	29.50/24.00/19.00	31.50/26.50/21.00
367/308/267	425/350/292	492/400/317	525/442/350
9.52	9.52	9.52	9.52
3/8	3/8	3/8	3/8
15.88	15.88	15.88	15.88
5/8	5/8	5/8	5/8
VP25 (OD 32, ID 25)	VP25 (OD 32, ID 25)	VP25 (OD 32, ID 25)	VP25 (OD 32, ID 25)
1.5-2.5	1.5-2.5	1.5-2.5	1.5-2.5
0.75-1.50	0.75-1.50	0.75-1.50	0.75-1.50
R32(Fluorinated greenhouse gas, GWP=675)			
EEV INCLUDED	EEV INCLUDED	EEV INCLUDED	EEV INCLUDED
40/36/32	40/36/32	42/38/33	44/40/35
57	58	60	61
20.0	24.0	24.0	24.0
947 x 281 x 947	947 x 365 x 947	947 x 365 x 947	947 x 365 x 947
PC6NUSMANW PC6EUSMANW PC6NBSMANW PC6EBSMANW PC6EUCMANW PC6EUXMANW	PC6NUSMANW PC6EUSMANW PC6NBSMANW PC6EBSMANW PC6EUCMANW PC6EUXMANW	PC6NUSMANW PC6EUSMANW PC6NBSMANW PC6EBSMANW PC6EUCMANW PC6EUXMANW	PC6NUSMANW PC6EUSMANW PC6NBSMANW PC6EBSMANW PC6EUCMANW PC6EUXMANW

Accessories



External Room Sensor	Panel (Mandatory)	Panel (Mandatory)	Panel (Mandatory)	Panel (Mandatory)	Air Purification Panel (Optional)	Auto Elevation Panel (Optional)	Motion Detect Sensor for PC4NUDMAN
MRW-TA	PC6NUSMANW	PC6EUSMANW	PC6NBSMANW	PC6EBSMANW	PC6EUCMANW	PC6EUXMANW	MCR-SME

LSP Slim Duct

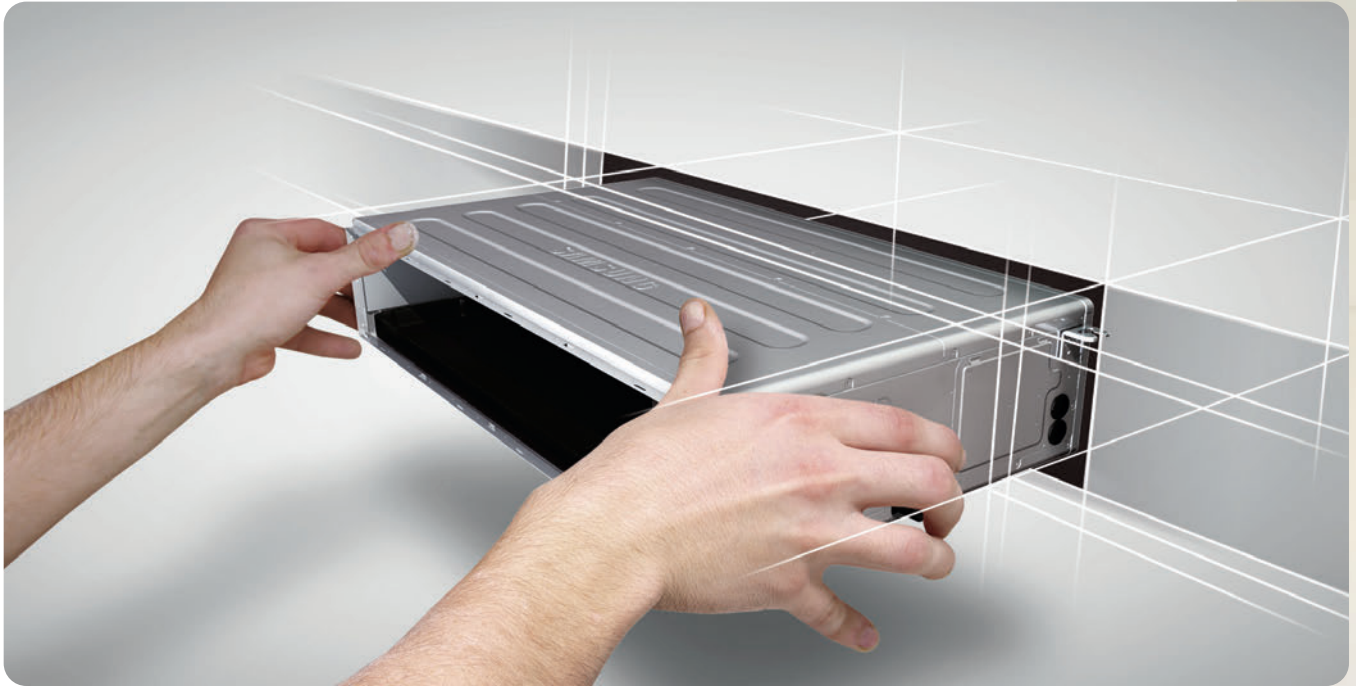

Slim design for small ceiling spaces

The Slim Duct S is 200 mm in height, making it much narrower than conventional products. This allows for easy installation and maintenance in all kinds of spaces.¹

¹ Based on the AM017-071*NLD*H/EU



Built-in check valve¹

A check valve prevents drained water from flowing back into the drain pan, minimising the water level in the drain pan. This modern design feature means no water stagnation, and prevents drain water overflowing into your interiors.

¹ Based on models AM***KNLDEH/EU, AM***MNLD*H/EU



Specifications

Universal LSP Duct (drain pump included)

- Two-position field adjustable air return, on the bottom or at the rear of the unit.
- Equipped with one Sirocco fan direct driven by a single motor.
- Auto Restart function.
- Built-in R32 refrigerant leak detect sensor.
- Built-in condensation drain pump (included).
- Wi-Fi Control with SmartThings via SmartPhone.
- Built-in Single Wi-Fi kit (MIM-H14EN)



Model			AM017DNLDKG/EU	AM022DNLDKG/EU	AM028DNLDKG/EU	AM036DNLDKG/EU
Power Supply		Φ, #, V, Hz	1Φ, 2, 220-240 V, 50/60 Hz	1Φ, 2, 220-240 V, 50/60 Hz	1Φ, 2, 220-240 V, 50/60 Hz	1Φ, 2, 220-240 V, 50/60 Hz
Performance						
Capacity (Nominal)	Cooling	kW	1.7	2.2	2.8	3.6
	Heating	kW	1.9	2.5	3.2	4.0
Power						
Power Input (Nominal)	Cooling	W	28	30	34	40
	Heating	W	28	30	36	42
Current Input (Nominal)	Cooling	A	0.23	0.25	0.28	0.33
	Heating	A	0.23	0.25	0.30	0.35
Fan						
Type		-	Sirocco Fan	Sirocco Fan	Sirocco Fan	Sirocco Fan
Motor	Output x n	W	69	69	69	69
Airflow Rate	H/M/L (UL)	m ³ /min	5.45/4.45/3.80	6.00/4.90/3.80	7.05/5.15/4.35	8.20/6.50/4.90
		l/s	91/74/63	100/82/63	118/86/73	137/108/82
External Static Pressure	Min/Std/Max	mmAq	0.00/1.00/3.00	0.00/1.00/3.00	0.00/1.00/3.00	0.00/1.00/3.00
		Pa	0.00/9.81/29.42	0.00/9.81/29.42	0.00/9.81/29.42	0.00/9.81/29.42
Piping Connections						
Liquid Pipe		Ø, mm	6.35	6.35	6.35	6.35
		Ø, inch	1/4	1/4	1/4	1/4
Gas Pipe		Ø, mm	12.7	12.70	12.70	12.70
		Ø, inch	1/2	1/2	1/2	1/2
Drain Pipe		Ø, mm	VP25 (OD 32, ID 25)	VP25 (OD 32, ID 25)	VP25 (OD 32, ID 25)	VP25 (OD 32, ID 25)
Field Wiring						
Transmission Cable		mm ²	0.75-1.50	0.75-1.50	0.75-1.50	0.75-1.50
Refrigerant						
Type		-	R32(Fluorinated greenhouse gas, GWP=675)			
Control Method		-	EEV INCLUDED	EEV INCLUDED	EEV INCLUDED	EEV INCLUDED
Sound						
Sound Pressure ¹	(H/M/L)	dB(A)	25/22/19	26/23/19	28/24/19	31/26/ 20
Sound Power	Cooling	dB(A)	40	42	44	46
Dimensions						
Net Weight		kg	15.9	15.9	15.9	16.3
Net Dimensions (W × H × D)		mm	700 x 199 x 440	700 x 199 x 440	700 x 199 x 440	700 x 199 x 440
Additional Accessories						
Drain Pump		-	Included	Included	Included	Included
Max. Lifting Height/Displacement		mm / litres/h	750/24	750/24	750/24	750/24

* Universal indoor units, universal controller and universal accessories can be installed both with DVM R410A and DVM R32 Outdoor units.

¹ Sound pressure level is obtained in an anechoic room. Sound pressure level is a relative value, depending on the distance and acoustic environment. Sound pressure level may differ depending on operation conditions.



AM045DNLDKG/EU	AM056DNLDKG/EU	AM071DNLDKG/EU
1Φ, 2, 220-240 V, 50/60 Hz	1Φ, 2, 220-240 V, 50/60 Hz	1Φ, 2, 220-240 V, 50/60 Hz
4.5	5.6	7.1
5.0	6.3	8.0
51	73	82
46	68	77
0.50	0.62	0.69
0.40	0.58	0.65
Sirocco Fan	Sirocco Fan	Sirocco Fan
84	84	84
12.50/10.00/7.50	15.50/12.50/9.50	18.00/14.50/11.00
208/167/125	258/208/158	300/242/183
0.00/2.00/4.00	0.00/2.00/4.00	0.00/2.00/4.00
0.00/19.61/39.23	0.00/19.61/39.23	0.00/19.61/39.23
6.35	6.35	9.52
1/4	1/4	3/8
12.70	12.70	15.88
1/2	1/2	5/8
VP25 (OD 32, ID 25)	VP25 (OD 32, ID 25)	VP25 (OD 32, ID 25)
0.75-1.50	0.75-1.50	0.75-1.50
R32(Fluorinated greenhouse gas, GWP=675)		
EEV INCLUDED	EEV INCLUDED	EEV INCLUDED
32 / 28 / 25	34 / 30 / 26	34 / 30 / 27
47	49	49
19.3	19.3	22.7
900 x 199 x 440	900 x 199 x 440	1100 x 199 x 440
Included	Included	Included
750/24	750/24	750/24

Controls



Wireless Remote Controller
AR-CH01E



Wireless Remote Controller
AR-EH03E
(to be matched with MRK-A10N)



Wireless Receiver Kit
MRK-A10N
(to be matched with AR-EH03E)



Touch Controller
MWR-SH11N



Wired Remote Controller
MWR-WG01*N



Wi-Fi Kit
MIM-H04EN

Accessories



External Room Sensor
MRW-TA

Specifications

LSP Duct (drain pump excluded, R410A)

- Two-position field adjustable air return, on the bottom or at the rear of the unit.
- Equipped with one Sirocco fan direct driven by a single motor.
- Long-life washable HD 40 permanent filter is included.
- Auto Restart function.
- Can be controlled by Smartphone via Wi-Fi Kit (Optional).



Model			AM017ANLDKH/EU	AM022ANLDKH/EU	AM028ANLDKH/EU	AM036ANLDKH/EU
Power Supply		Φ, #, V, Hz	1Φ, 2, 220–240 V, 50/60 Hz	1Φ, 2, 220–240 V, 50/60 Hz	1Φ, 2, 220–240 V, 50/60 Hz	1Φ, 2, 220–240 V, 50/60 Hz
Performance						
Capacity (Nominal)	Cooling	kW	1.7	2.2	2.8	3.6
	Heating	kW	1.9	2.5	3.2	4.0
Power						
Power Input (Nominal)	Cooling	W	28	30	34	40
	Heating	W	28	30	36	42
Current Input (Nominal)	Cooling	A	0.23	0.25	0.28	0.33
	Heating	A	0.23	0.25	0.30	0.35
Fan						
Type		-	Sirocco Fan	Sirocco Fan	Sirocco Fan	Sirocco Fan
Motor	Output x n	W	69 x 1	69 x 1	69 x 1	69 x 1
Airflow Rate	H/M/L (UL)	m ³ /min	5.5 / 4.5 / 3.8	6.0 / 4.9 / 3.8	7.1 / 5.2 / 4.4	8.2 / 6.5 / 4.9
		l/s	91 / 74 / 63	100 / 82 / 63	118 / 86 / 73	137/108 / 82
External Static Pressure	Min/Std/Max	mmAq	0.0 / 1.0 / 3.0	0.0 / 1.0 / 3.0	0.0 / 1.0 / 3.0	0.0 / 1.0 / 3.0
		Pa	0.00/9.81/29.42	0.00/9.81/29.42	0.00/9.81/29.42	0.00/9.81/29.42
Piping Connections						
Liquid Pipe		Ø, mm	6.35	6.35	6.35	6.35
		Ø, inch	1/4	1/4	1/4	1/4
Gas Pipe		Ø, mm	12.70	12.70	12.70	12.70
		Ø, inch	1/2	1/2	1/2	1/2
Drain Pipe		Ø, mm	VP25 (OD 32, ID 25)	VP25 (OD 32, ID 25)	VP25 (OD 32, ID 25)	VP25 (OD 32, ID 25)
Field Wiring						
Power Source Wire	Below 20 m/over 20 m	mm ²	1.5/2.5	1.5/2.5	1.5/2.5	1.5/2.5
Transmission Cable		mm ²	0.75–1.50	0.75–1.50	0.75–1.50	0.75–1.50
Refrigerant						
Type		-		R410A (Fluorinated greenhouse gas, GWP=2,088)		
Control Method		-	EEV INCLUDED	EEV INCLUDED	EEV INCLUDED	EEV INCLUDED
Sound						
Sound Pressure ¹	(H/M/L)	dB(A)	25 / 22 / 19	26 / 23 / 19	28 / 24 / 19	31 / 26 / 20
Sound Power		dB(A)	40	42	44	46
Dimensions						
Net Weight		kg	14.9	14.9	14.9	15.3
Net Dimensions (W x H x D)		mm	700 x 199 x 440	700 x 199 x 440	700 x 199 x 440	700 x 199 x 440
Air Filter			Long-life Filter	Long-life Filter	Long-life Filter	Long-life Filter
Accessories						
Drain Pump		-	MDP-Z075SZED	MDP-Z075SZED	MDP-Z075SZED	MDP-Z075SZED

Controls



Wireless Remote Controller	Wireless Remote Controller	Wireless Receiver Kit	Touch Controller	Wired Remote Controller	Wi-Fi Kit
AR-CH01E	AR-EH03E (to be matched with MRK-A10N)	MRK-A10N (to be matched with AR-EH03E)	MWR-SH11N	MWR-WG01*N	MIM-H04EN

¹ Sound pressure level is obtained in an anechoic room. Sound pressure level is a relative value, depending on the distance and acoustic environment. Sound pressure level may differ depending on operation conditions.



AM045ANLDKH/EU	AM056ANLDKH/EU	AM071ANLDKH/EU	AM090ANLDKH/EU
1Φ, 2, 220–240 V, 50/60 Hz	1Φ, 2, 220–240 V, 50/60 Hz	1Φ, 2, 220–240 V, 50/60 Hz	1Φ, 2, 220–240 V, 50/60 Hz
4.5	5.6	71	9.0
5.0	6.3	8.0	10.0
51	73	82	170
46	68	77	170
0.45	0.62	0.69	0.96
0.41	0.58	0.65	0.96
Sirocco Fan	Sirocco Fan	Sirocco Fan	Sirocco Fan
84 x 1	84 x 1	84 x 1	183 x 1
12.5 / 10.0 / 7.5	15.5 / 12.5 / 9.5	18.0 / 14.5 / 11.0	29.0 / 27.0 / 25.0
208/167 / 125	258/208 / 158	300/242 / 183	483/450 / 417
0.0 / 2.0 / 4.0	0.0 / 2.0 / 4.0	0.0 / 2.0 / 4.0	0.0 / 3.0 / 6.0
0.00/19.61/39.23	0.00/19.61/39.23	0.00/19.61/39.23	0.00/29.42/58.84
6.35	6.35	9.52	9.52
1/4	1/4	3/8	3/8
12.70	12.70	15.88	15.88
1/2	1/2	5/8	5/8
VP25 (OD 32, ID 25)	VP25 (OD 32, ID 25)	VP25 (OD 32, ID 25)	VP25 (OD 32, ID 25)
1.5/2.5	1.5/2.5	1.5/2.5	1.5/2.5
0.75–1.50	0.75–1.50	0.75–1.50	0.75–1.50
	R410A (Fluorinated greenhouse gas, GWP=2,088)		
EEV INCLUDED	EEV INCLUDED	EEV INCLUDED	EEV INCLUDED
32 / 28 / 25	34 / 30 / 26	34 / 30 / 27	37 / 36 / 34
47	49	49	66
18.8	18.8	22.0	40.0
900 x 199 x 440	900 x 199 x 440	1,100 x 199 x 440	1,300 x 295 x 690
Long-life Filter	Long-life Filter	Long-life Filter	Long-life Filter
MDP-Z075SZED	MDP-Z075SZED	MDP-Z075SZED	MDP-E075SEE3D

Accessories



External Room Sensor

MRW-TA



Drain pump

MDP-E075SEE3D
MDP-Z075SZED

MSP/HSP Duct S¹

Easy installation and maintenance

Thanks to their ultra-compact design, Samsung duct units can be placed anywhere. This makes for easy installation and maintenance.

The indoor unit can be accessed from three directions: from the top, bottom and one side, making maintenance simpler than ever.

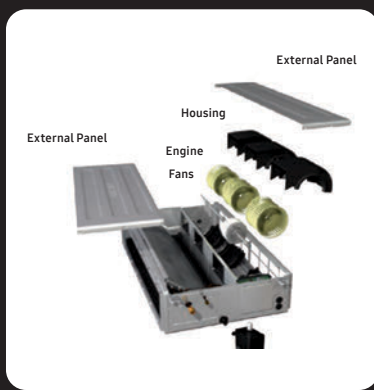

Accessible from top

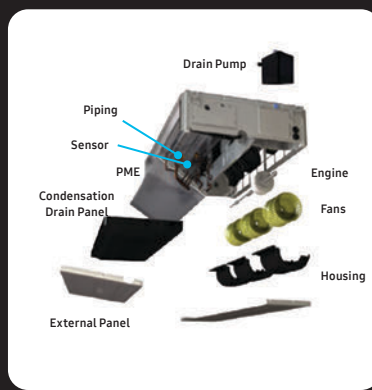

Accessible from bottom

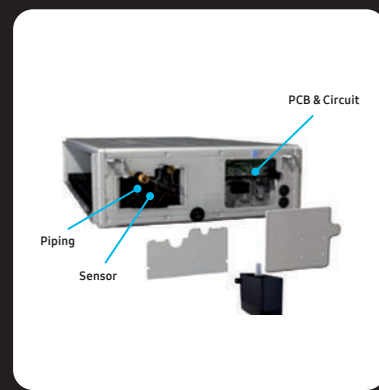

Accessible from side

Installation flexibility and easy maintenance with a lightweight and compact Slim Fit design

The compact and lightweight Slim Fit Design allows you to fit your air conditioner unit into small spaces, thus facilitating its

handling as well as the set up. This means you can now install it in most places within a building with minimum difficulty.



¹ Based on model AM***AN*PKH/EU



Indoor discharge temperature

Each ducted indoor unit, or Air Handling Unit (AHU) kit, boosts discharge air temperature control function that offers greater comfort without the need to change the outdoor unit setting. Cooling and heating options can be selected using a remote control, and this applies to all ducted/AHU connected systems.

Automatic External Static Pressure (ESP) setting

The automatic operation of the external static pressure feature is very simple to set up. This auto setting enables you to choose the optimal operating range for the fan. The result is the greatest possible comfort with an optimal balance

between sound level and capacity. Please contact your Samsung representative to find out which indoor units feature this function.

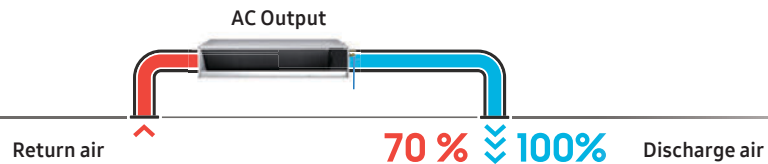
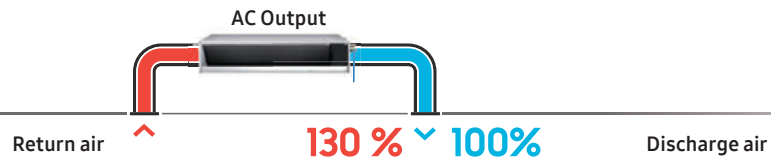

Specifications

Universal MSP Duct (drain pump included)

- Two-position field adjustable air return, on the bottom or at the rear of the unit.
- Equipped with one Sirocco fan direct driven by a single motor.
- Built-in R32 refrigerant leak detect sensor.
- Auto Restart function.
- Automatic ESP setting.
- Built-in condensation drain pump.
- Wi-Fi Control with SmartThings via SmartPhone.
- Built-in Single Wi-Fi kit (MIM-H14EN)



Model			AM022DNMDKG/EU	AM028DNMDKG/EU	AM036DNMDKG/EU	AM045DNMDKG/EU
Power Supply		Φ, #, V, Hz	1Φ, 2, 220-240 V, 50/60 Hz	1Φ, 2, 220-240 V, 50/60 Hz	1Φ, 2, 220-240 V, 50/60 Hz	1Φ, 2, 220-240 V, 50/60 Hz
Performance						
Capacity (Nominal)	Cooling	kW	2.2	2.8	3.6	4.5
	Heating	kW	2.5	3.2	4.0	5.0
Power						
Power Input (Nominal)	Cooling	W	42	42	45	55
	Heating	W	42	42	45	55
Current Input (Nominal)	Cooling	A	0.4	0.4	0.4	0.5
	Heating	A	0.4	0.4	0.4	0.5
Current Input (Nominal)	MCA	A	0.67	0.67	0.81	0.89
	MFA/MOP	A	15	15	15	15
Fan						
Type	-		Sirocco Fan	Sirocco Fan	Sirocco Fan	Sirocco Fan
Number of Fans	ea		2	2	2	2
Airflow Rate	H/M/L (UL)	m ³ /min	10.5 / 9.0 / 7.0	10.5 / 9.0 / 7.0	12.0 / 9.5 / 7.5	14.0 / 11.0 / 8.0
		l/s	170 / 150 / 115	170 / 150 / 115	200 / 158 / 125	233 / 183 / 133
External Pressure	Min/Std/Max	mmAq	0 / 2.5 / 15	0 / 2.5 / 15	0 / 2.5 / 15	0 / 3 / 15
		Pa	0.00 / 24.52 / 147.10	0.00 / 24.52 / 147.10	0.00 / 24.52 / 147.10	0.00 / 29.42 / 147.10
Fan Motor						
Model	-		BLDC	BLDC	BLDC	BLDC
Output x n	W		153	153	153	153
Piping Connections						
Liquid Pipe	Ø, mm		6.35	6.35	6.35	6.35
	Ø, inch		1/4	1/4	1/4	1/4
Gas Pipe	Ø, mm		12.70	12.70	12.70	12.70
	Ø, inch		1/2	1/2	1/2	1/2
Drain Pipe	Ø, mm		VP25 (OD 32, ID 25)	VP25 (OD 32, ID 25)	VP25 (OD 32, ID 25)	VP25 (OD 32, ID 25)
Wiring Connections						
Connection with Indoor	Minimum	mm ²	0.75	0.75	0.75	0.75
	Remark	-	F1, F2	F1, F2	F1, F2	F1, F2
Refrigerant						
Type	-		R32(Fluorinated greenhouse gas, GWP=675)			
Control Method	-		EEV Included	EEV Included	EEV Included	EEV Included
Sound						
Sound Pressure ¹	(H/M/L)	dB(A)	28/26/24	28/26/24	30/27/24	31/28/25
Sound Power	Cooling (Nominal)	dB(A)	50	51	53	54
Dimensions						
Net Weight	kg		27	27	27	27
Net Dimensions (W × H × D)	mm		850 x 250 x 700	850 x 250 x 700	850 x 250 x 700	850 x 250 x 700
Additional Accessories						
Drain Pump	Model		INCLUDED	INCLUDED	INCLUDED	INCLUDED
	Max. Lifting Height	mm/ Liter/H	750/ 24	750/ 24	750/ 24	750/ 24

Controls

						
Wireless Remote Controller	Wireless Remote Controller	Wireless Receiver Kit	Touch Controller	Wired Remote Controller	Wi-Fi Kit	External Room Sensor
AR-CH01E	AR-EH03E (to be matched with MRK-A10N)	MRK-A10N (to be matched with AR-EH03E)	MWR-SH11N	MWR-WG01*N	MIM-H04EN	MRW-TA

Accessories

* Universal indoor units, universal controller and universal accessories can be installed both with DVM R410A and DVM R32 Outdoor units.

¹ Sound pressure level is obtained in an anechoic room. Sound pressure level is a relative value, depending on the distance and acoustic environment. Sound pressure level may differ depending on operation conditions.



AM056DNMDKG/EU	AM071DNMDKG/EU	AM090DNMDKG/EU	AM112DNMDKG/EU	AM128DNMDKG/EU	AM140DNMDKG/EU	AM160DNMDKG/EU
1Φ, 2, 220-240 V, 50/60 Hz	1Φ, 2, 220-240 V, 50/60 Hz	1Φ, 2, 220-240 V, 50/60 Hz	1Φ, 2, 220-240 V, 50/60 Hz	1Φ, 2, 220-240 V, 50/60 Hz	1Φ, 2, 220-240 V, 50/60 Hz	1Φ, 2, 220-240 V, 50/60 Hz
5.6	7.1	9.0	11.2	12.8	14.0	16.0
6.3	8.0	10.0	12.5	13.8	16.0	18.0
70	110	135	130	160	210	300
70	110	135	130	160	210	300
0.6	1.0	1.2	1.2	1.4	1.7	2.45
0.6	1.0	1.2	1.2	1.4	1.7	2.45
1.08	1.48	1.78	1.97	2.17	2.38	3.6
15	15	15	15	15	15	15
Sirocco Fan 2	Sirocco Fan 2	Sirocco Fan 3	Sirocco Fan 3	Sirocco Fan 3	Sirocco Fan 3	Sirocco Fan 3
16.0 / 13.5 / 9.0	22.0 / 18.0 / 13.0	27.0 / 22.0 / 16.0	30.0 / 25.0 / 18.0	36.0 / 30.0 / 23.0	40.0 / 34.0 / 24.0	45.0 / 35.0 / 25.0
267 / 225 / 150	350 / 300 / 217	450 / 367 / 267	500 / 417 / 300	600 / 500 / 383	667 / 567 / 400	750 / 583 / 417
0 / 3 / 15	0 / 3 / 15	0 / 4 / 15	0 / 5.2 / 15	0 / 5.2 / 15	0 / 5.2 / 15	0 / 5.2 / 15
0.00/29.42/147.10	0.00/29.42/147.10	0.00 / 39.23/147.10	0.00 / 50.99/ 147.10	0.00 / 50.99/ 147.10	0.00 / 50.99/ 147.10	0.00 / 51.0/ 147.10
BLDC	BLDC	BLDC	BLDC	BLDC	BLDC	BLDC
153	153	153	244	244	244	350
6.35	9.52	9.52	9.52	9.52	9.52	9.5
1/4	3/8	3/8	3/8	3/8	3/8	3/8
12.70	15.88	15.88	15.88	15.88	15.88	15.88
1/2	5/8	5/8	5/8	5/8	5/8	5/8
VP25 (OD 32, ID 25)	VP25 (OD 32, ID 25)	VP25 (OD 32, ID 25)	VP25 (OD 32, ID 25)	VP25 (OD 32, ID 25)	VP25 (OD 32, ID 25)	VP25 (OD 32, ID 25)
0.75	0.75	0.75	0.75	0.75	0.75	0.75
F1, F2	F1, F2	F1, F2	F1, F2	F1, F2	F1, F2	F1, F2
R32(Fluorinated greenhouse gas, GWP=675)						
EEV Included	EEV Included	EEV Included	EEV Included	EEV Included	EEV Included	EEV Included
32/29/25	36/32/27	37/33/29	36/33/30	37/34/31	39/36/33	43/39/35
57	60	61	61	62	64	65
27	27	34.2	39.4	39.4	39.4	44.5
850 x 250 x 700	850 x 250 x 700	1,200 x 250 x 700	1,300 x 300 x 700	1,300 x 300 x 700	1,300 x 300 x 700	1300 x 300 x 700
INCLUDED	INCLUDED	INCLUDED	INCLUDED	INCLUDED	INCLUDED	INCLUDED
750/ 24	750/ 24	750/ 24	750/ 24	750/ 24	750/ 24	750/ 24

Specifications

Universal Sensible MSP Duct (drain pump included)

- Two-position field adjustable air return, on the bottom or at the rear of the unit.
- Equipped with one Sirocco fan direct driven by a single motor.
- Auto Restart function.
- Automatic ESP setting.
- Built-in condensation drain pump.
- Built-in R32 refrigerant leak detect sensor.
- Wi-Fi Control with SmartThings via SmartPhone.
- Built-in Single Wi-Fi kit (MIM-H14EN)



Model			AM022DNMFKG/EU	AM028DNMFKG/EU	AM036DNMFKG/EU	AM045DNMFKG/EU
Power Supply		Φ, #, V, Hz	1Φ, 2, 220-240 V, 50/60 Hz	1Φ, 2, 220-240 V, 50/60 Hz	1Φ, 2, 220-240 V, 50/60 Hz	1Φ, 2, 220-240 V, 50/60 Hz
Performance						
Capacity (Nominal)	Cooling	kW	2.2	2.8	3.6	4.5
	Heating	kW	2.5	3.2	4.0	5.0
Power						
Power Input (Nominal)	Cooling	W	25	30	40	50
	Heating	W	25	30	40	50
Current Input (Nominal)	Cooling	A	0.19	0.22	0.29	0.37
	Heating	A	0.19	0.22	0.29	0.37
Current Input (Nominal)	MCA	A	0.78	0.91	1.04	1.22
	MFA/MOP	A	15	15	15	15
Fan						
Type	-		Sirocco Fan	Sirocco Fan	Sirocco Fan	Sirocco Fan
Number of Fans	ea		3	3	3	3
Airflow Rate	H/M/L (UL)	m ³ /min	10/9.5/9	12.5/11/10.5	15/13/12	18.5 / 16 / 13.5
		l/s	167/158/150	208/183/175	250/217/200	308 / 267 / 225
External Pressure	Min/Std/Max	mmAq	0/3/15	0/3/15	0/3/15	0 / 3 / 15
		Pa	0.00 / 29.42 / 147.1	0.00 / 29.42 / 147.1	0.00 / 29.42 / 147.1	0.00 / 29.42 / 147.10
Fan Motor						
Model	-		BLDC	BLDC	BLDC	BLDC
Output x n	W		153	153	153	153
Piping Connections						
Liquid Pipe	Ø, mm		6.35	6.35	6.35	6.35
		Ø, inch	1/4	1/4	1/4	1/4
Gas Pipe	Ø, mm		12.70	12.70	12.70	12.70
		Ø, inch	1/2	1/2	1/2	1/2
Drain Pipe	Ø, mm		VP25 (OD 32, ID 25)	VP25 (OD 32, ID 25)	VP25 (OD 32, ID 25)	VP25 (OD 32, ID 25)
Wiring Connections						
Connection with Indoor	Minimum	mm ²	0.75	0.75	0.75	0.75
	Remark	-	F1, F2	F1, F2	F1, F2	F1, F2
Refrigerant						
Type	-		R32(Fluorinated greenhouse gas, GWP=675)			
Control Method	-		EEV Included	EEV Included	EEV Included	EEV Included
Sound						
Sound Pressure ¹	(H/M/L)	dB(A)	33/31/29	33/31/29	34/31/28	34/31/28
Sound Power	Cooling (Nominal)	dB(A)	55	56	57	57
Dimensions						
Net Weight		kg	34.2	34.2	34.2	34.2
Net Dimensions (W × H × D)		mm	1200 x 250 x 700	1200 x 250 x 700	1200 x 250 x 700	1200 x 250 x 700
Additional Accessories						
Drain Pump	Model		INCLUDED	INCLUDED	INCLUDED	INCLUDED
	Max. Lifting Height	mm/ Liter/H	750/24	750/24	750/24	750/24

* Universal indoor units, universal controller and universal accessories can be installed both with DVM R410A and DVM R32 Outdoor units.

¹ Sound pressure level is obtained in an anechoic room. Sound pressure level is a relative value, depending on the distance and acoustic environment. Sound pressure level may differ depending on operation conditions.



AM056DNMFKG/EU	AM071DNMFKG/EU
1Φ, 2, 220-240 V, 50/60 Hz	1Φ, 2, 220-240 V, 50/60 Hz
5.6	7.1
6.3	8.0
90	135
90	135
0.66	0.98
0.66	0.98
1.45	2.17
15	15
Sirocco Fan	Sirocco Fan
3	3
24 / 21.5 / 18.5	32 / 28.5 / 24.5
400 / 358 / 308	533 / 475 / 408
0 / 5.2 / 15	0 / 5.2 / 15
0 / 51.0 / 147.1	0 / 51.0 / 147.1
BLDC	BLDC
244	244
6.35	9.52
1/4	3/8
12.70	15.88
1/2	5/8
VP25 (OD 32, ID 25)	VP25 (OD 32, ID 25)
0.75	0.75
F1, F2	F1, F2
R32(Fluorinated greenhouse gas, GWP=675)	
EEV Included	EEV Included
38/35/31	39/35/30
63	63
39.4	39.4
1300 x 300 x 700	1300 x 300 x 700
INCLUDED	INCLUDED
750/24	750/24

Controls



NEW



Wireless Remote Controller

Wireless Remote Controller

Wireless Receiver Kit

AR-CH01E

AR-EH03E
(to be matched with
MRK-A10N)

MRK-A10N
(to be matched with
AR-EH03E)



Touch Controller

Wired Remote Controller

Wi-Fi Kit

MWR-SH11N

MWR-WG01*N

MIM-H04EN

Accessories



External Room Sensor

MRW-TA

Specifications

Universal HSP Duct

- Two-position field adjustable air return, on the bottom or at the rear of the unit.
- Equipped with two Sirocco fans direct driven by a single motor.
- Auto Restart function.
- Built-in R32 refrigerant leak detect sensor.
- Auto ESP setting (model-specific).
- Long-life HD 40 permanent filter is included (model-specific).
- Wi-Fi Control with SmartThings via SmartPhone.
- Built-in Single Wi-Fi kit (MIM-H14EN)



Model			AM090DNHDKG/EU	AM12DNHDKG/EU	AM128DNHDKG/EU
Power Supply		Φ, #, V, Hz	1,2,220-240,50/60	1,2,220-240,50/60	1,2,220-240,50/60
Performance					
Capacity (Nominal)	Cooling	kW	9.0	11.2	12.8
	Heating	kW	10.0	12.5	13.8
Power					
Power Input (Nominal)	Cooling	W	145.0	130	185
	Heating	W	145.0	130	185
Current Input (Nominal)	Cooling	A	1.20	1.2	1.3
	Heating	A	1.20	1.2	1.3
Current Input (Nominal)	MCA	A	2.05	2.41	2.96
	MFA/MOP	A	15	15	15
Fan					
Type			Sirocco Fan	Sirocco Fan	Sirocco Fan
Number of Fans	ea		3	3	3
Airflow Rate	H/M/L (UL)	m ³ /min	29.00/25.00/22.00	32.0 / 26.0 / 20.0	37.0 / 30.0 / 22.0
		l/s	483 / 417 / 367	533 / 433 / 333	617 / 500 / 367
External Static Pressure	Min/Std/Max	mmAq	0/3/20	3 / 6.2 / 20	3 / 6.2 / 20
		Pa	0 / 29.42 / 196.13	29.42 / 60.80 / 196.13	29.42 / 60.80 / 196.13
Fan Motor					
Model			BLDC motor	BLDC motor	BLDC motor
Output x n	W		153 x 1	350 x 1	350 x 1
Piping Connections					
Liquid Pipe	Ø, mm		9.52	9.52	9.52
	Ø, inch		3/8	3/8	3/8
Gas Pipe	Ø, mm		15.88	15.88	15.88
	Ø, inch		5/8	5/8	5/8
Drain Pipe	Ø, mm		VP25 (OD 32,ID 25)	VP25 (OD 32,ID 25)	VP25 (OD 32,ID 25)
Field Wiring					
Power Source Wire	Below 20 m/ over 20 m	mm ²	1.5	1.5	1.5
Transmission Cable	Transmission Cable	mm ²	0.75	0.75	0.75
	Remark	-	F1,F2	F1,F2	F1,F2
Refrigerant					
Type			R32(Fluorinated greenhouse gas, GWP=675)		
Control Method			EEV INCLUDED	EEV INCLUDED	EEV INCLUDED
Sound²					
Sound Pressure ¹	(H/M/L)	dB(A)	34/31/28	36/33/30	39/36/33
Sound Power	Cooling	dB(A)	60	61	64
Dimensions					
Net Weight	kg		34.2	44.5	44.5
Net Dimensions (W x H x D)	mm		1200x250x700	1300 x 300 x 700	1300 x 300 x 700
Additional Accessories					
Drain Pump	Internal	-	INCLUDED	INCLUDED	INCLUDED
	Max. Lifting Height/ Displacement	mm / litres/h	750/24	750/24	750/24

* Universal indoor units, universal controller and universal accessories can be installed both with DVM R410A and DVM R32 Outdoor units.

¹ Sound pressure level is obtained in an anechoic room. Sound pressure level is a relative value, depending on the distance and acoustic environment. Sound pressure level may differ depending on operation conditions.



AM140DNHDKG/EU

1,2,220~240,50/60

14.0
16.0

220
220
1.5
1.5
3.23
15

Sirocco Fan
3

41.0 / 34.0 / 25.0
683 / 567 / 417
3 / 6.2 / 20
29.42 / 60.80 / 196.13

BLDC motor
350 x 1

9.52
3/8
15.88
5/8

VP25 (OD 32, ID 25)

1.5
0.75
F1,F2

R32(Fluorinated greenhouse gas, GWP=675)
EEV INCLUDED

42/38/34
65

44.5
1300 x 300 x 700

INCLUDED
750/24

Controls



NEW



Wireless Remote Controller

AR-CH01E

Wireless Remote Controller

AR-EH03E
(to be matched with
MRK-A10N)

Wireless Receiver Kit

MRK-A10N
(to be matched with
AR-EH03E)



Touch Controller

MWR-SH11N



Wired Remote Controller

MWR-WG01*N



Wi-Fi Kit

MIM-H04EN

Accessories



External Room Sensor

MRW-TA

Specifications

HSP Duct (R410A)

- Equipped with two Sirocco fans direct driven by a single motor.
- Long-life HD 40 permanent filter is included (model-specific).
- Can be controlled by Smartphone via Wi-Fi Kit (Optional).
- Two-position field adjustable air return, on the bottom or at the rear of the unit.
- Auto Restart function.
- Auto ESP setting (model-specific).



Model			AM180JNHFKH/EU	AM224JNHFKH/EU	AM220FNHDEH/EU
Power Supply		Φ, #, V, Hz	1Φ, 2, 220-240 V, 50 Hz		
Performance					
Capacity (Nominal)	Cooling	kW	18.0	22.4	22.4
	Heating	kW	20.0	25.0	25.0
Power					
Power Input (Nominal)	Cooling	W	340	530	530
	Heating	W	340	530	530
Current Input (Nominal)	Cooling	A	1.90	2,9	3.80
	Heating	A	1.90	2,9	3.80
Current Input (Nominal)	MCA	A	5.72	-	5.80
	MFA/MOP	A	15	-	15
Fan					
Type			Sirocco Fan		
Number of Fans	ea		1		
Airflow Rate	H/M/L (UL)	m ³ /min	58.0 / 50.0 / 43.0		
		l/s	966.67/833.33/716.67		
External Static Pressure	Min/Std/Max	mmAq	5.00/7.34/20.00		
		Pa	49.00/71.93/196.00		
Fan Motor					
Model			-		
Output x n	W		630 x 1		
Piping Connections					
Liquid Pipe	Ø, mm		9.52		
	Ø, inch		3/8		
Gas Pipe	Ø, mm		19.05		
	Ø, inch		3/4		
Drain Pipe	Ø, mm		VP25 (OD 25, ID 20)		
Field Wiring					
Power Source Wire	Below 20 m/ over 20 m	mm ²	1.5/2.5		
Transmission Cable	Transmission Cable	mm ²	0.75-1.50		
	Remark	-	F1,F2		
Refrigerant					
Type			R410A (Fluorinated greenhouse gas, GWP=2,088)		
Control Method			EEV INCLUDED		
Sound¹					
Sound Pressure ¹	(H/M/L)	dB(A)	43/39/35		45/43/41
			80		81
Sound Power	Cooling	dB(A)	80		
Dimensions					
Net Weight	kg		82.5		
Net Dimensions (W x H x D)	mm		1350 x 450 x 910		
Air Filter			-		
Additional Accessories					
Drain Pump	Internal	-	MDP-G075SQ		
	External	-	MDP-G075SP		
	Max. Lifting Height/ Displacement	mm / litres/h	-		
			MDP-N0475NC1D		
			-		
			750/24		

* Universal indoor units, universal controller and universal accessories can be installed both with DVM R410A and DVM R32 Outdoor units.

¹ Sound pressure level is obtained in an anechoic room. Sound pressure level is a relative value, depending on the distance and acoustic environment. Sound pressure level may differ depending on operation conditions.



AM280FNHDEH/EU

1Φ, 2, 220-240 V, 50 Hz

28.0
31.5

790
790
5.90
5.90
8.64
15

Sirocco Fan
1

72.0 / 65.0 / 58.0
1200.00/1083.33/966.67
5.00/15.00/28.00
49.03/147.10/274.59

-
400 x1

9.52
3/8
22.23
7/8

VP25 (OD 32, ID 25)

1.5/2.5
0.75-1.50
F1,F2

R410A (Fluorinated greenhouse gas, GWP=2,088)
EEV INCLUDED

48/46/43

89.0
1240 x 470 x 1040
-

MDP-N047SNC1D
-

750/24

Controls



NEW

Wireless Remote Controller

AR-CH01E



Wireless Remote Controller

AR-EH03E
(to be matched with
MRK-A10N)



Wireless Receiver Kit

MRK-A10N
(to be matched with
AR-EH03E)



Touch Controller

MWR-SH11N



Wired Remote Controller

MWR-WG01*N



Wi-Fi Kit

MIM-H04EN

Accessories



External Room Sensor

MRW-TA



Drain Pump (optional)

MDP-G075SP/Q



Drain Pump (optional)

MDP-N047SNC1D

Specifications

Universal Floor/Ceiling

- Optional vertical or horizontal installation.
- Air supply by means of one adjustable blade.
- Reduced noise thanks to the remotely controlled EEV.
- Built-in R32 refrigerant leak detect sensor.
- Wi-Fi Control with SmartThings via SmartPhone.
- Built-in Single Wi-Fi kit (MIM-H14EN).



Model			AM056DNCDKG/EU
Power Supply		Φ, #, V, Hz	1Φ, 2, 220-240 V, 50/60 Hz
Performance			
Capacity (Nominal)	Cooling	kW	5,6
	Heating	kW	6.3
Power			
Power Input (Nominal)	Cooling	W	50
	Heating	W	50
Current Input (Nominal)	Cooling	A	0.43
	Heating	A	0.43
Fan			
Motor	Type	-	BLDC
	Output	W	40
	Number of Fans	ea	2
Airflow Rate	H/M/L (UL)	m ³ /min	12.6/ 11.3/ 10
		l/s	233/217/200
Piping Connections			
Liquid Pipe	Ø, mm		6.35
	Ø, inch		1/4
Gas Pipe	Ø, mm		12.70
	Ø, inch		1/2
Drain Pipe	Ø, mm		ID 18 HOSE
Field Wiring			
Transmission Cable		mm ²	0.75
Refrigerant			
Type	-		R32(Fluorinated greenhouse gas, GWP=675)
Control Method	-		EEV INCLUDED
Sound			
Sound Pressure ¹	(H/M/L)	dB(A)	41/39/36
Dimensions			
Net Weight		kg	20.8
Net Dimensions (W × H × D)		mm	1000 x 650 x 200

Controls



Touch Controller

MWR-SH11N



Wired Remote Controller

MWR-WG01*N



Wi-Fi Kit

MIM-H04EN

Accessories



External Room Sensor

MRW-TA

* Universal indoor units, universal controller and universal accessories can be installed both with DVM R410A and DVM R32 Outdoor units.

¹ Sound pressure level is obtained in an anechoic room. Sound pressure level is a relative value, depending on the distance and acoustic environment. Sound pressure level may differ depending on operation conditions.

Specifications

Universal Big Ceiling

- Horizontal installation only.
- Air supply by means of one adjustable blade.
- Sirocco Fan direct driven by a single motor.
- Built-in R32 refrigerant leak detect sensor.
- Wi-Fi Control with SmartThings via SmartPhone.
- Built-in Single Wi-Fi kit (MIM-H14EN)



Model			AM071DNCDKG/EU	AM112DNCDKG/EU	AM140DNCDKG/EU
Power Supply		Φ, #, V, Hz	1Φ, 2, 220-240 V, 50/60 Hz	1Φ, 2, 220-240 V, 50/60 Hz	1Φ, 2, 220-240 V, 50/60 Hz
Performance					
Capacity (Nominal)	Cooling	kW	7.1	11.2	14.0
	Heating	kW	8.0	12,5	16.0
Power					
Power Input (Nominal)	Cooling	W	51	92	160
	Heating	W	51	80	160
Current Input (Nominal)	Cooling	A	0.47	0.94	1.45
	Heating	A	0.47	0.83	1.45
Fan					
Motor	Type	-	Sirocco Fan	Sirocco Fan	Sirocco Fan
	Output	W	153	153	244
Airflow Rate	H/M/L (UL)	m ³ /min	18.4/16.4/14.3	29.30/23.90/18.50	36.40/30.80/26.00
		l/s	300/275/250	488/398/308	607/513/433
Piping Connections					
Liquid Pipe		Ø, mm	9.52	9.52	9.52
		Ø, inch	3/8	3/8	3/8
Gas Pipe		Ø, mm	15.88	15.88	15.88
		Ø, inch	5/8	5/8	5/8
Drain Pipe		Ø, mm	VP25 (OD 25, ID 20)	VP25 (OD 25, ID 20)	VP25 (OD 25, ID 20)
Field Wiring					
Transmission Cable		mm ²	0.75	0.75	0.75
Refrigerant					
Type		-	R32(Fluorinated greenhouse gas, GWP=675)		
Control Method		-	EEV INCLUDED	EEV INCLUDED	EEV INCLUDED
Sound					
Sound Pressure ¹	(H/M/L)	dB(A)	37/35/33	45/41/37	46/43/38
Sound Power	Cooling	dB(A)	56	61	63
Dimensions					
Net Weight		kg	34	34	42
Net Dimensions (W × H × D)		mm	1,350 x 235 x 675	1,350 x 235 x 675	1,650 x 235 x 675

Controls



Touch Controller
MWR-SH11N



Wired Remote Controller
MWR-WG01*N



Wi-Fi Kit
MIM-H04EN

Accessories



External Room Sensor
MRW-TA

* Universal indoor units, universal controller and universal accessories can be installed both with DVM R410A and DVM R32 Outdoor units.

¹ Sound pressure level is obtained in an anechoic room. Sound pressure level is a relative value, depending on the distance and acoustic environment. Sound pressure level may differ depending on operation conditions.

Specifications

Console (R410A)

- Slim design: only 199 mm in depth.
- Turbo fan with single-phase inverter motor.
- Two separate air outlets to avoid stratification.
- Long-life washable permanent filter.
- Can be controlled by Smartphone via Wi-Fi Kit (Optional).
- Auto Restart function.



Model			AM022KNJDEH/EU	AM028FNJDEH/EU	AM036FNJDEH/EU	AM045KNJDEH/EU	AM056FNJDEH/EU
Power Supply			Φ, #, V, Hz				
			1Φ, 2, 220-240 V, 50 Hz	1Φ, 2, 220-240 V, 50 Hz	1Φ, 2, 220-240 V, 50 Hz	1Φ, 2, 220-240 V, 50 Hz	1Φ, 2, 220-240 V, 50 Hz
Performance							
Capacity (Nominal)	Cooling	kW	2.8	2.8	3.6	4.5	5.6
	Heating	kW	3.2	3.2	4	5	6.3
Power							
Power Input (Nominal)	Cooling	W	30	30	35	36	62
	Heating	W	30	30	35	36	62
Current Input (Nominal)	Cooling	A	0.25	0.25	0.29	0.30	0.49
	Heating	A	0.25	0.25	0.29	0.30	0.49
Fan							
Motor	Type	-	Turbo Fan	Turbo Fan	Turbo Fan	Turbo Fan	Turbo Fan
	Output	W	37	37	37	37	37
	Number of Fans	ea	1	1	1	1	1
Airflow Rate	H/M/L (UL)	m ³ /min	7.00/6.00/5.00	7.00/6.00/5.00	8.50/7.50/6.50	11.30/9.80/8.20	13.00/11.50/10.00
		l/s	116.67/100.00/83.33	116.67/100.00/83.33	141.67/125.00/108.33	188.33/163.33/136.67	216.67/191.67/166.67
Piping Connection							
Liquid Pipe	Ø, mm	Ø, mm	6.35	6.35	6.35	6.35	6.35
		Ø, inch	1/4	1/4	1/4	1/4	1/4
Gas Pipe	Ø, mm	Ø, mm	12.7	12.7	12.7	12.7	12.7
		Ø, inch	1/2	1/2	1/2	1/2	1/2
Drain Pipe	Ø, mm	Ø, mm	ID 18 HOSE	ID 18 HOSE	ID 18 HOSE	ID 18 HOSE	ID 18 HOSE
Field Wiring							
Power Source Wire		mm ²	1.5/2.5	1.5/2.5	1.5/2.5	1.5/2.5	1.5/2.5
Transmission Cable		mm ²	0.75-1.50	0.75-1.50	0.75-1.50	0.75-1.50	0.75-1.50
Refrigerant							
Type		-	R410A (Fluorinated greenhouse gas, GWP=2,088)				
Control Method		-	EEV INCLUDED	EEV INCLUDED	EEV INCLUDED	EEV INCLUDED	EEV INCLUDED
Sound							
Pressure ¹	(H/M/L)	dB(A)	38/36/34	38/36/34	39/37/34	42/39/36	43/40/37
Power	Cooling	dB(A)	58	58	59	63	64
Dimensions							
Net Weight		kg	16.0	16.0	16.0	16.0	16.0
Net Dimensions (W x H x D)		mm	720 x 620 x 199	720 x 620 x 199	720 x 620 x 199	720 x 620 x 199	720 x 620 x 199
Air Filter		-	-	Long-life Filter	Long-life Filter	-	Long-life Filter

Controls



Wireless Remote Controller

(included with holder)



Touch Controller

MWR-SH11N



Wired Remote Controller

MWR-WG01*N



Wi-Fi Kit

MIM-H04EN

Accessories



External Room Sensor

MRW-TA

¹ Sound pressure level is obtained in an anechoic room. Sound pressure level is a relative value, depending on the distance and acoustic environment. Sound pressure level may differ depending on operation conditions.

Specifications

Concealed Floor-Standing (R410A)

- Silent operation.
- Sirocco fan driven by inverter motor.
- Can be controlled by Smartphone via Wi-Fi Kit.
- Long-life washable permanent filter.
- Auto Restart function.



Model			AM036FNFDEH/EU	AM056FNFDEH/EU	AM071FNFDEH/EU
Power Supply			1Φ, 2, 220-240 V, 50 Hz		
Performance					
Capacity (Nominal)	Cooling	kW	3.6	5.6	7.1
	Heating	kW	4.0	6.3	8.0
Power					
Power Input (Nominal)	Cooling	W	50	110	110
	Heating	W	50	110	110
Current Input (Nominal)	Cooling	A	0.24	0.53	0.53
	Heating	A	0.24	0.53	0.53
Fan					
Motor	Type	-	Sirocco Fan	Sirocco Fan	Sirocco Fan
Airflow Rate	H/M/L (UL)	m ³ /min	10.00/8.50/6.00	15.50/14.00/11.00	15.50/14.00/11.00
		L/s	166.67/141.67/100.00	258.33/233.33/183.33	258.33/233.33/183.33
Piping Connections					
Liquid Pipe		Ø, mm	6.35	9.52	9.52
		Ø, inch	1/4	3/8	3/8
Gas Pipe		Ø, mm	12.70	15.88	15.88
		Ø, inch	1/2	5/8	5/8
Drain Pipe		Ø, mm	ID 18 HOSE	ID 18 HOSE	ID 18 HOSE
Field Wiring					
Power Source Wire	Below 20 m/ over 20 m	mm ²	1.5/2.5	1.5/2.5	1.5/2.5
Transmission Cable		mm ²	0.75-1.50	0.75-1.50	0.75-1.50
Refrigerant					
Type		-	R410A (Fluorinated greenhouse gas, GWP=2,088)		
Control Method		-	EEV INCLUDED	EEV INCLUDED	EEV INCLUDED
Sound					
Sound Pressure ¹	(H/M/L)	dB(A)	37/32/27	40/36/32	40/36/32
Dimensions					
Net Weight		kg	23.0	28.5	28.5
Net Dimensions (W × H × D)		mm	945 x 600 x 220	1,225 x 600 x 220	1,225 x 600 x 220
Air Filter			Long-Life Filter	Long-Life Filter	Long-Life Filter

Controls



Touch Controller

MWR-SH11N



Wired Remote Controller

MWR-WG01*N



Wi-Fi Kit

MIM-H04EN

Accessories



External Room Sensor

MRW-TA

¹ Sound pressure level is obtained in an anechoic room. Sound pressure level is a relative value, depending on the distance and acoustic environment. Sound pressure level may differ depending on operation conditions.

Specifications

Concealed Floor-Standing High static pressure (R410A)

- Silent operation.
- Sirocco fan driven by inverter motor.
- Can be controlled by Smartphone via Wi-Fi Kit.
- Long-life washable permanent filter.
- Auto Restart function.



Model			AM036MNFDEH/EU	AM056MNFDEH/EU	AM071MNFDEH/EU
Power Supply		Φ, #, V, Hz	1Φ, 2, 220-240 V, 50 Hz	1Φ, 2, 220-240 V, 50 Hz	1Φ, 2, 220-240 V, 50 Hz
Performance					
Capacity (Nominal)	Cooling	kW	3.6	5.6	7.1
	Heating	kW	4.0	6.3	8.0
Power					
Power Input (Nominal)	Cooling	kW	0.022	0.042	0.042
	Heating	kW	0.022	0.042	0.042
Current Input (Nominal)	Cooling	A	0.20	0.37	0.37
	Heating	A	0.20	0.37	0.37
Fan					
Motor	Type	-	Sirocco Fan	Sirocco Fan	Sirocco Fan
	Output x n	W	100 x 1	100 x 1	100 x 1
External Static Pressure	Min/Std/Max	mmAq	0.00/3.00/6.00	0.00/3.00/6.00	0.00/3.00/6.00
	Min/Std/Max	Pa	0.00/29.40/58.90	0.00/29.40/58.90	0.00/29.40/58.90
Airflow Rate	(H/M/L)	m³/h	600/510/360	930/840/660	930/840/660
Piping Connections					
Liquid Pipe	Ø, mm		6.35	6.35	9.52
	Ø, inch		1/4	1/4	3/8
Gas Pipe	Ø, mm		12.70	12.70	15.88
	Ø, inch		1/2	1/2	5/8
Drain Pipe	Ø, mm		ID 18 HOSE	ID 18 HOSE	ID 18 HOSE
Field Wiring					
Power Source Wire		mm²	1.5-2.5	1.5-2.5	1.5-2.5
Transmission Cable		mm²	0.75-1.50	0.75-1.50	0.75-1.50
Refrigerant					
Type		-	R410A (Fluorinated greenhouse gas, GWP=2,088)		
Control Method		-	EEV INCLUDED	EEV INCLUDED	EEV INCLUDED
Sound					
Sound Pressure ¹	(H/M/L)	dB(A)	37/32/27	40/36/32	40/36/32
Sound Power		dB(A)	53.0	59.0	59.0
Dimensions					
Net Weight		kg	22.0	27.0	27.0
Net Dimensions (W x H x D)		mm	945 x 600 x 220	1,225 x 600 x 220	1,225 x 600 x 220
Air Filter			Long-life Filter	Long-life Filter	Long-life Filter

Accessories



Touch Controller

MWR-SH11N



Wired Remote Controller

MWR-WG01*N



Wi-Fi Kit

MIM-H04EN



External Room Sensor

MRW-TA

¹ Sound pressure level is obtained in an anechoic room. Sound pressure level is a relative value, depending on the distance and acoustic environment. Sound pressure level may differ depending on operation conditions.

Specifications

Packaged Floor-Standing (R410A)

- Sirocco fan driven by upgraded BLDC motor.
- Auto external static pressure control
- Embedded single Wi-Fi kit helps to control via SmartPhone



Model			AM140RNPDKH/EU	AM280CNPDKH/EU
Power Supply		Φ, #, V, Hz	1Φ, 2, 220~240 V, 50/60 Hz	1Φ, 2, 220~240 V, 50/60 Hz
Performance				
Capacity (Nominal)	Cooling	kW	14	28
	Heating	kW	16	31.5
Power				
Power Input (Nominal)	Cooling	W	190	400
	Heating	W	190	400
Current Input (Nominal)	Cooling	A	0.90	2.7
	Heating	A	0.90	2.7
Fan				
Motor	Type	-	Sirocco Fan	Sirocco Fan
	Output x n	W	154 x 1	630 x 1
Airflow Rate	H/M/L (UL)	m ³ /min	35.00/30.50/27.50	68.00/63.00/58.00
		l/s	583.33/508.33/458.33	2401.5 / 2224.9 / 2048.3
Piping Connections				
Liquid Pipe	Ø, mm	Ø, mm	9.52	9.52
		Ø, inch	3/8	3/8
Gas Pipe	Ø, mm	Ø, mm	15.88	22.22
		Ø, inch	5/8	7/8
Drain Pipe	Ø, mm		ID 18 HOSE	VP25 (OD 32, ID 25)
Field Wiring				
Power Source Wire		mm ²	2.5	0.75
Transmission Cable		mm ²	VCTF 0.75~1.50	VCTF 0.75~1.50
Refrigerant				
Type		-	R410A (Fluorinated greenhouse gas, GWP=2,088)	
Control Method		-	EEV INCLUDED	
Sound				
Sound Pressure ¹	(H/M/L Silent)	dB(A)	54/47	58/56/54
Sound Power	Cooling	dB(A)	-	74
Dimension				
Net Weight		kg	48.0	108
Net Dimensions (W x H x D)		mm	610 x 1,850 x 400	1,100 x 1,800 x 485
Connectivity			Single Wi-Fi Kit embedded	

Controls



Touch Controller

MWR-SH11N



Wired Remote Controller

MWR-WG01*N



Single Wi-Fi Kit

Included for AM280CNPDKH/EU



Wi-Fi Kit (optional)

MIM-H04EN



External Room Sensor

MRW-TA

Accessories

¹ Sound pressure level is obtained in an anechoic room. Sound pressure level is a relative value, depending on the distance and acoustic environment. Sound pressure level may differ depending on operation conditions.





WindFree™ Deluxe



UNIQUE

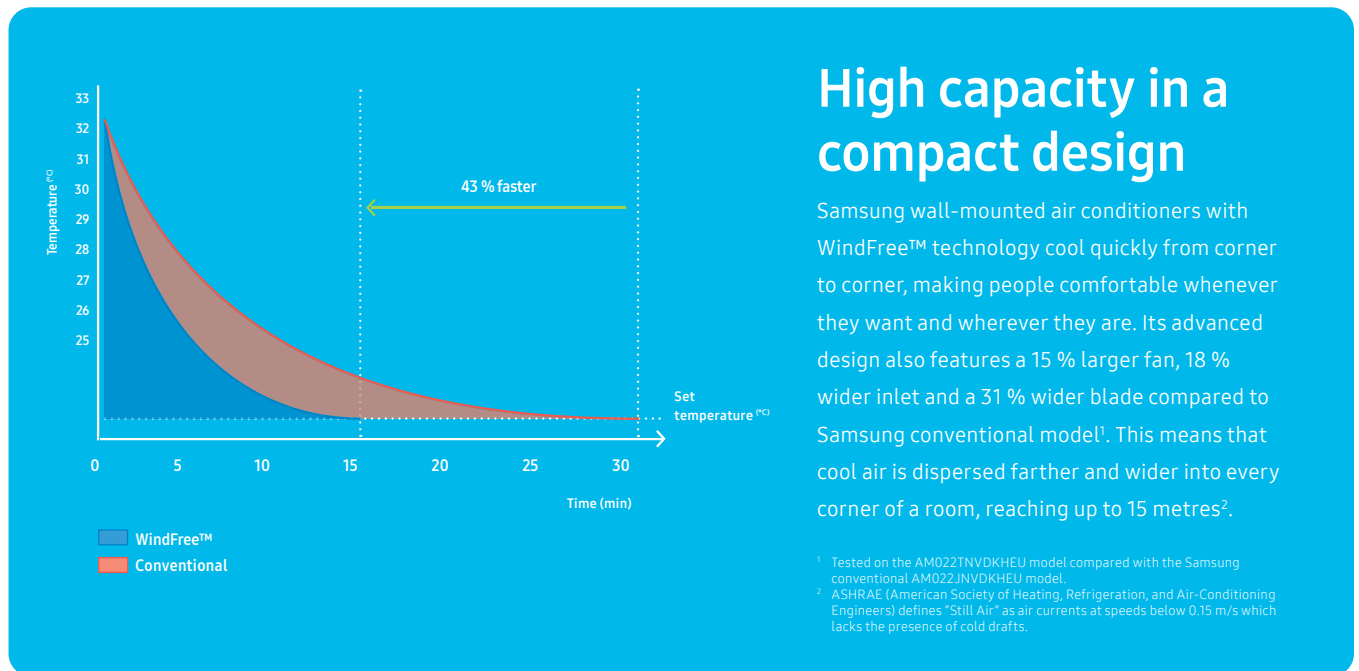
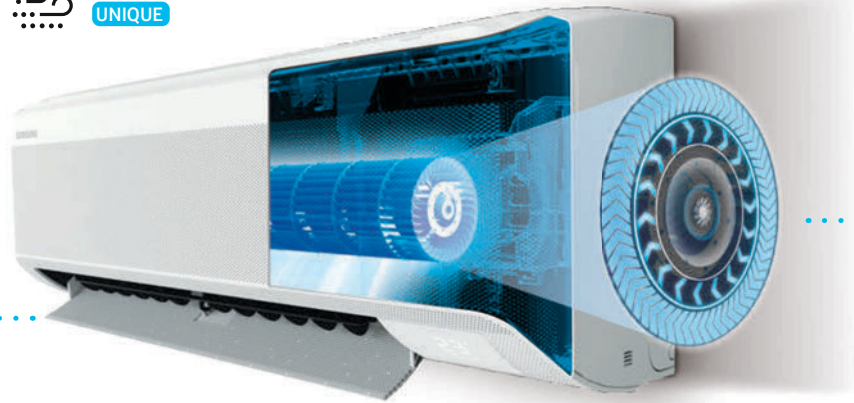
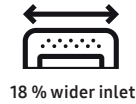

Easy Installation and Servicing

The WindFree™ wall-mounted air conditioner features a snap-fit bottom cover that can be easily opened and closed. There are two screw points which allows for convenient installation and servicing. Unlike conventional brackets that can be fitted on two fixed hooks, the unit uses a roller type bracket that simplifies the installation process. This makes it easy to mount by installing the bracket on the wall and sliding it effortlessly into the exact position you want.



Samsung's roller type bracket makes mounting the unit much easier. Simply hang it on the unit and find the best place to install it by sliding the bracket from side to side.

Assembled parts (6)/
Screw points (5)

Installation time¹:
9.3 min

45% ↓



Assembled parts (3)/
Screw points (2)

Installation time¹:
5.1 min

¹ Tested on the AM022TNVDKHEU model compared with the Samsung conventional AM022JNVDKHEU model under specific conditions and may vary on specific factors

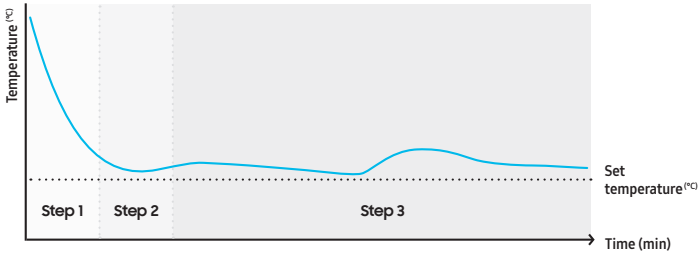
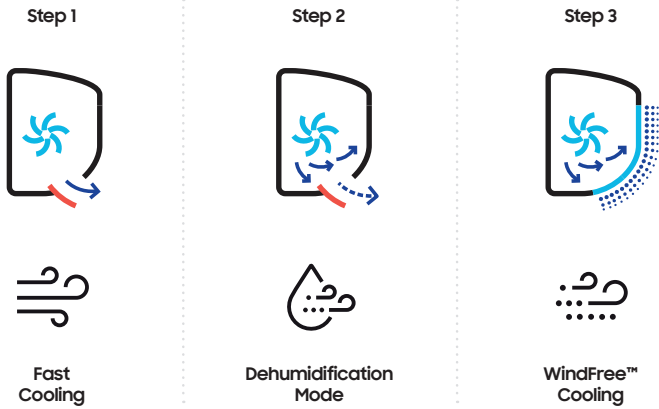

WindFree™ Cooling mode

WindFree™ Cooling mode keeps the room comfortably cool. It cools gently and quietly, dispersing air through 23,000 micro-holes so that people do not have to deal with the unpleasant feeling of a cold draft on their skin. This results in a “Still Air” environment¹ with a very low air speed and limited noise². The advanced airflow structure of this mode also means that it cools a wider and larger area more evenly. And it consumes 77 % less energy than Fast Cooling mode³, so people can stay comfortably cool while reducing energy costs.

¹ ASHRAE (the American Society of Heating, Refrigerating, and Air-Conditioning Engineers) defines “Still Air” as air currents moving at speeds below 0.15 m/s, with no cold drafts.
² Tested on the AR12TXCAAWKNEU model in an anechoic environment. WindFree™ mode generates 23 dB(A) of noise, compared to 26 dB(A) produced by the conventional Samsung model. Sound pressure level is a relative value, depending on the distance and acoustic environment. Sound pressure level may differ according to operating conditions.
³ Tested on the AR12TVEAAWKNA model under specific testing conditions, based on the power consumption of Fast Cooling mode vs. WindFree™ Cooling mode.



Smart Control

Control the temperature in any room, anytime and anywhere. Temperatures can be managed remotely using the SmartThings App¹. With just a simple touch you can turn it on and off, select the cooling mode, schedule its operation and group devices. With the optional Wi-Fi Kit, the different aspects of the system with up to 16 connectible indoor units can be controlled via smartphone.

¹ A Wi-Fi connection and Samsung SmartThings application account are required. Wi-Fi Kit to be ordered separately. Requires iOS 10.0 or later & Android 5.0 or later. Additional requirements may be needed to apply SmartThings for medium-sized to large commercial buildings. For details contact a Samsung representative.

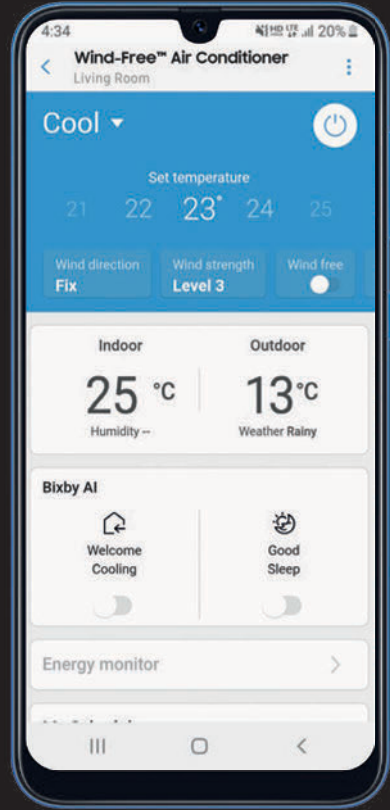

Not all features are available for all models.

Specifications

Universal WindFree™ Deluxe (EEV included) UNIQUE

- Three-step cooling: Fast Cooling mode, Dehumidification mode and WindFree™ Cooling mode.
- Wi-Fi Control with SmartThings.
- Built-in R32 refrigerant leak detect sensor.
- Built-in Single Wi-Fi kit (MIM-H14EN)



			AM015DNVDKG/EU	AM022DNVDKG/EU	AM028DNVDKG/EU
Power Supply		Φ, #, V, Hz	1Φ, 2, 220~240 V, 50/60 Hz	1Φ, 2, 220~240 V, 50/60 Hz	1Φ, 2, 220~240 V, 50/60 Hz
Performance					
Capacity (Nominal)	Cooling	kW	1.5	2.2	2.8
	Heating	kW	1.7	2.5	3.2
Power					
Capacity (Nominal)	Cooling	W	20	24	30
	Heating	W	20	24	30
Current Input (Nominal)	Cooling	A	0.13	0.16	0.20
	Heating	A	0.13	0.16	0.20
MCA		A	0.16	0.2	0.25
MFA		A	15	15	15
Fan					
Motor	Type	-	Crossflow Fan	Crossflow Fan	Crossflow Fan
	Output	W	27 x 1	27 x 1	27 x 1
Airflow Rate	H/M/L (UL)	m ³ /min	4.9/4.5/4.1	5.7/5.0/4.5	8.5/7.7/6.9
		l/s	81.7/75.0/68.3	95.0/83.3/75.0	141.7/128.3/115.0
Piping Connections					
Liquid Pipe	Ø, mm		6.35	6.35	6.35
	Ø, inch		1/4	1/4	1/4
Gas Pipe	Ø, mm		12.70	12.70	12.70
	Ø, inch		1/2	1/2	1/2
Drain Pipe	Ø, mm		ID 18 HOSE	ID 18 HOSE	ID 18 HOSE
Field Wiring					
Transmission Cable		mm ²	0.75	0.75	0.75
Remark		-	F1, F2	F1, F2	F1, F2
Refrigerant					
Type		-	R32(Fluorinated greenhouse gas, GWP=675)		
Control Method		-	EEV INCLUDED	EEV INCLUDED	EEV INCLUDED
Sound					
Sound Pressure¹	(H/M/L/W)	dB(A)	31/30/27/26	34/32/30/27	34/33/32/26
Sound Power	Cooling	dB(A)	50	51	52
Dimensions					
Net Weight		kg	9.0	8.7	9.5
Net Dimensions (W × H × D)		mm	820 x 299 x 215	820 x 299 x 215	820 x 299 x 215

Controls



Wireless Remote Controller
AR-CH01E



Wireless Remote Controller
AR-EH03E



Touch Controller
MWR-SH11N



Wired Remote Controller
MWR-WG01*N



Wi-Fi Kit
MIM-H04EN



External Room Sensor
MRW-TA

Accessories

* Universal indoor units, universal controller and universal accessories can be installed both with DVM R410A and DVM R32 Outdoor units.

¹ Sound pressure level is obtained in an anechoic room. Sound pressure level is a relative value, depending on the distance and acoustic environment. Sound pressure level may differ depending on operation conditions.



AM036DNVDKG/EU	AM045DNVDKG/EU	AM056DNVDKG/EU	AM071DNVDKG/EU	AM082DNVDKG/EU
1Φ, 2, 220-240 V, 50/60 Hz	1Φ, 2, 220-240 V, 50/60 Hz	1Φ, 2, 220-240 V, 50/60 Hz	1Φ, 2, 220-240 V, 50/60 Hz	1Φ, 2, 220-240 V, 50/60 Hz
3.6	4.5	5.6	6.8	8.2
4.0	5.0	6.3	7.0	8.5
37	40	52	60	65
37	40	52	60	65
0.25	0.27	0.35	0.40	0.43
0.25	0.27	0.35	0.40	0.43
0.31	0.34	0.44	0.5	0.54
15	15	15	15	15
Crossflow Fan 27 x 1	Crossflow Fan 27 x 1	Crossflow Fan 27 x 1	Crossflow Fan 27 x 1	Crossflow Fan 27 x 1
10.3/9.1/8.3	12.5/11.4/10.5	15.7/13.8/12.0	16.8/15.0/13.2	17.5/15.6/13.8
171.7/151.7/138.3	208.3/190.0/175.0	261.7/230.0/200.0	280.0/250.0/220.0	291.7/260.0/230.0
6.35	6.35	6.35	9.52	9.52
1/4	1/4	1/4	3/8	3/8
12.70	12.70	12.70	15.88	15.88
1/2	1/2	1/2	5/8	5/8
ID 18 HOSE	ID 18 HOSE	ID 18 HOSE	ID 18 HOSE	ID 18 HOSE
0.75	0.75	0.75	0.75	0.75
F1, F2	F1, F2	F1, F2	F1, F2	F1, F2
R32(Fluorinated greenhouse gas, GWP=675)				
EEV INCLUDED	EEV INCLUDED	EEV INCLUDED	EEV INCLUDED	EEV INCLUDED
40/36/34/26	37/34/33/29	40/37/34/29	43/40/37/29	46/45/43/30
56	55	58	62	64
9.5	12.0	12.0	12.0	13.0
820 x 299 x 215	1055 x 299 x 215	1055 x 299 x 215	1055 x 299 x 215	1055 x 299 x 215

Specifications

WindFree™ Deluxe (EEV excluded, R410A) UNIQUE

- Three-step cooling: Fast Cooling mode, Dehumidification mode and WindFree™ Cooling mode.
- Wi-Fi Control with SmartThings and Bixby voice controls (Optional).
- Equipped with Easy Filter Plus.



			AM015TNADKH/EU	AM022TNADKH/EU	AM028TNADKH/EU
Power Supply	Φ, #, V, Hz		1Φ, 2, 220-240 V, 50/60 Hz	1Φ, 2, 220-240 V, 50/60 Hz	1Φ, 2, 220-240 V, 50/60 Hz
Performance					
Capacity (Nominal)	Cooling	kW	1.5	2.2	2.8
	Heating	kW	1.7	2.5	3.2
Power					
Capacity (Nominal)	Cooling	W	20	24	30
	Heating	W	20	24	30
Current Input (Nominal)	Cooling	A	0.13	0.16	0.20
	Heating	A	0.13	0.16	0.20
MCA	A		0.2	0.2	0.3
MFA	A		15	15	15
Fan					
Motor	Type	-	Crossflow Fan	Crossflow Fan	Crossflow Fan
	Output	W	27 x 1	27 x 1	27 x 1
Airflow Rate	H/M/L (UL)	m³/min	4.9/4.5/4.1	5.7/5.0/4.5	8.5/7.7/6.9
		l/s	81.7/75.0/68.3	95.0/83.3/75.0	141.7/128.3/115.0
Piping Connections					
Liquid Pipe	Ø, mm		6.35	6.35	6.35
	Ø, inch		1/4	1/4	1/4
Gas Pipe	Ø, mm		12.70	12.70	12.70
	Ø, inch		1/2	1/2	1/2
Drain Pipe	Ø, mm		ID 18 HOSE	ID 18 HOSE	ID 18 HOSE
Field Wiring					
Power Source Wire	mm²		1.5/2.5	1.5/2.5	1.5/2.5
Transmission Cable	mm²		0.75-1.50	0.75-1.50	0.75-1.50
Remark	-		F1, F2	F1, F2	F1, F2
Refrigerant					
Type	-		R410A (Fluorinated greenhouse gas, GWP = 2,088)		
Control Method¹	-		EEV NOT INCLUDED	EEV NOT INCLUDED	EEV NOT INCLUDED
Sound					
Sound Pressure²	(H/M/L)	dB(A)	31/30/27/26 (WindFree™)	34/32/30/27 (WindFree™)	34/33/32/26 (WindFree™)
Sound Power	Cooling	dB(A)	50	51	52
Dimensions					
Net Weight	kg		8.5	8.5	9.0
Net Dimensions (W × H × D)	mm		820 x 299 x 215	820 x 299 x 215	820 x 299 x 215
Air Filter			Easy Filter Plus	Long-life Filter	Long-life Filter

Controls



Wireless Remote Controller	Wireless Remote Controller	Touch Controller	Wired Remote Controller	Wi-Fi Kit
AR-CH01E	AR-EH03E	MWR-SH11N	MWR-WG01*N	MIM-H04EN

¹ EEV Kit is necessary to control the refrigerant flow in the WindFree™ Deluxe (EEV Excluded), please order EEV Kit separately.

² Sound pressure level is obtained in an anechoic room. Sound pressure level is a relative value, depending on the distance and acoustic environment. Sound pressure level may differ depending on operation conditions.



AM036TNADKH/EU	AM045TNADKH/EU	AM056TNADKH/EU	AM071TNADKH/EU	AM082TNADKH/EU
1Φ, 2, 220-240 V, 50/60 Hz	1Φ, 2, 220-240 V, 50/60 Hz	1Φ, 2, 220-240 V, 50/60 Hz	1Φ, 2, 220-240 V, 50/60 Hz	1Φ, 2, 220-240 V, 50/60 Hz
3.6	4.5	5.6	6.8	8.2
4.0	5.0	6.3	7.0	8.5
37	40	52	60	65
37	40	52	60	65
0.25	0.27	0.35	0.40	0.43
0.25	0.27	0.35	0.40	0.43
0.3	0.3	0.4	0.5	0.5
15	15	15	15	15
Crossflow Fan	Crossflow Fan	Crossflow Fan	Crossflow Fan	Crossflow Fan
27 x1	27 x1	27 x1	27 x1	27 x1
10.3/9.1/8.3	12.5/11.4/10.5	15.7/13.8/12.0	16.8/15.0/13.2	17.5/15.6/13.8
171.7/151.7/138.3	208.3/190.0/175.0	261.7/230.0/200.0	280.0/250.0/220.0	291.7/260.0/230.0
6.35	6.35	6.35	9.52	9.52
1/4	1/4	1/4	3/8	3/8
12.70	12.70	12.70	15.88	15.88
1/2	1/2	1/2	5/8	5/8
ID 18 HOSE	ID 18 HOSE	ID 18 HOSE	ID 18 HOSE	ID 18 HOSE
1.5/2.5	1.5/2.5	1.5/2.5	1.5/2.5	1.5/2.5
0.75-1.50	0.75-1.50	0.75-1.50	0.75-1.50	0.75-1.50
F1, F2	F1, F2	F1, F2	F1, F2	F1, F2
R410A (Fluorinated greenhouse gas, GWP = 2,088)				
EEV NOT INCLUDED	EEV NOT INCLUDED	EEV NOT INCLUDED	EEV NOT INCLUDED	EEV NOT INCLUDED
40/36/34/26 (WindFree™)	37/34/33/29 (WindFree™)	40/37/34/29 (WindFree™)	43/40/37/29 (WindFree™)	46/45/43/30 (WindFree™)
56	55	58	62	64
9.0	11.5	11.5	11.5	12.5
820 x 299 x 215	1055 x 299 x 215	1055 x 299 x 215	1055 x 299 x 215	1055 x 299 x 215
Long-life Filter	Long-life Filter	Long-life Filter	Long-life Filter	Long-life Filter

Accessories



External Room Sensor

EEV Kit 1 Indoor

EEV Kit 2 Indoor

EEV Kit 3 Indoor

MRW-TA

MEV-***SA

MXD-E24/32K***A

MXD-E24/32K***A

Specifications

Universal Max Wall-Mounted

- Cross-flow fan direct driven by a single BLDC motor.
- Built-in R32 refrigerant leak detect sensor.
- Wi-Fi Control with SmartThings via SmartPhone.
- Return air is filtered by means of an easily removable, washable pre filter.
- Built-in Single Wi-Fi kit (MIM-H14EN)
- Motorised louvre provides an automatic change in airflow by directing the air up and down.
- Manual adjustable guide vane allows users to change the airflow from side to side (left to right).



Model			AM093DNQDKG/EU
Power Supply	Φ, #, V, Hz		1Φ, 2, 220-240 V, 50/60 Hz
Performance			
Capacity	Cooling	kW	9.3
	Heating	kW	9.8
Power			
Power Input	Cooling	W	66
	Heating	W	76
Current Input	Cooling	A	0.47
	Heating	A	0.54
Current	MCA	A	0.68
	MFA	A	15
Fan			
Type	-		Crossflow Fan
Number of Fans	ea		1
Airflow Rate	H/M/L	m ³ /min	23/20/17
		L/s	383/333/283
Fan Motor			
Type	-		BLDC Motor
Output x n	W		58 x 1
Piping Connections			
Liquid Pipe		Ø, mm	9.52
		Ø, inch	3/8
Gas Pipe		Ø, mm	15.88
		Ø, inch	5/8
Drain Pipe		Ø, mm	ID 18 HOSE
Wiring Connections			
Communication	Min.	mm ²	0.75
	Remark	-	F1, F2
Refrigerant			
Type	-		R32(Fluorinated greenhouse gas, GWP=675)
Electronic Expansion Valve	-		EEV INCLUDED
Sound			
Sound Pressure ¹	H/M/L	dB(A)	49/46/42
Sound Power	Cooling	dB(A)	66
Dimensions			
Net Weight		kg	18.5
Net Dimensions (W × H × D)		mm	1,280 x 345 x 253

Controls



Touch Controller

MWR-SH11N



Wired Remote Controller

MWR-WG01*N



Wi-Fi Kit

MIM-H04EN



External Room Sensor

MRW-TA

Accessories

* Universal indoor units, universal controller and universal accessories can be installed both with DVM R410A and DVM R32 Outdoor units.

¹ Sound pressure level is obtained in an anechoic room. Sound pressure level is a relative value, depending on the distance and acoustic environment. Sound pressure level may differ depending on operation conditions.



DVM Hydro Unit

Performance

The Samsung DVM Hydro unit provides a single solution for cooling, heating and hot water that is both efficient and easy to manage.



An Integrated Solution in One System

The DVM Hydro system is compatible with all DVM S Mini R32 and DVM S2 outdoor units and can be added to create a single, integrated solution for cooling, heating and hot water that's simple to manage. So it ensures much greater efficiency to suit a variety of demands, generating substantial energy and cost savings with its high-efficiency heat pump technology.



2 Types - with a Choice of Hot Water needs

The DVM Hydro is available in two types. The DVM Hydro HE provides water at a mid temperature of 50°C, while the DVM Hydro HT's advanced, double compression technology generates much hotter water at 80°C. The perfect solution to satisfy the requirements of various sites.

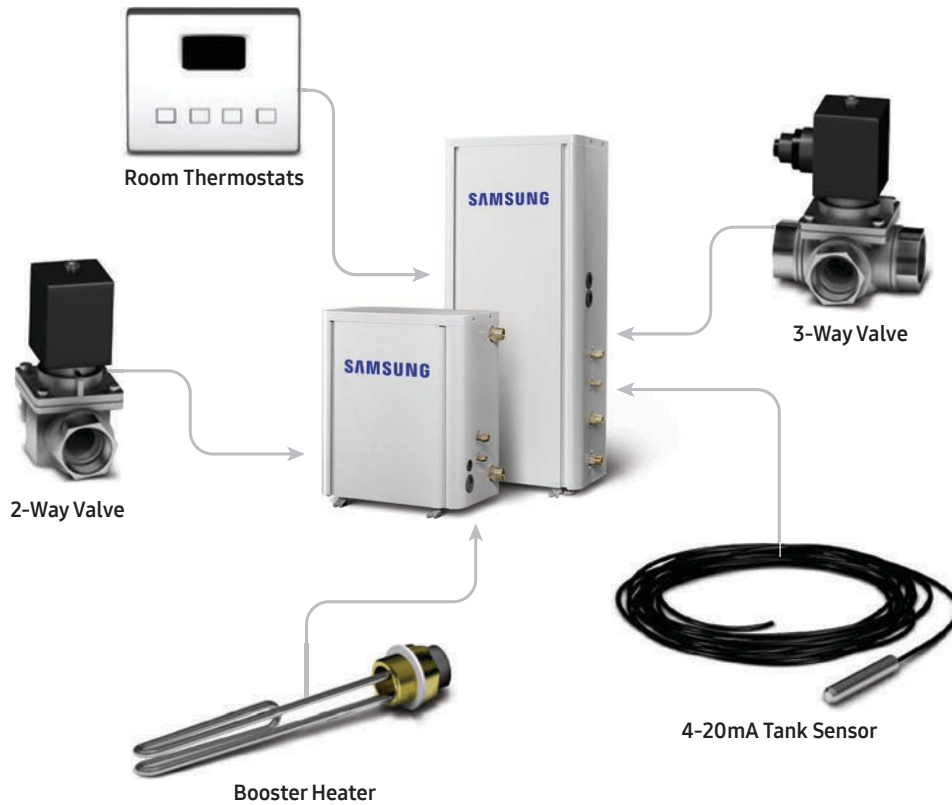

Integrated Control System

The DVM Hydro can be independently or centrally operated along with a variety of Samsung DVM systems. For standalone use on individual sites it has its own control system or, using the Samsung DVM S Controller, it can be integrated with various DVM systems eg. for water and air, and managed centrally.

Simple & Easy Connection for External Control

The DVM Hydro is very quick and easy to install and use for many different purposes. It includes a range of connections for various external input and output devices, such as Tank Sensors, Booster Heaters, 2- and 3-Way Valves, and Room Thermostats.

Installation & Control

The Samsung DVM Hydro is easy to install and connect to a range of other devices, and can also be independently or centrally controlled.

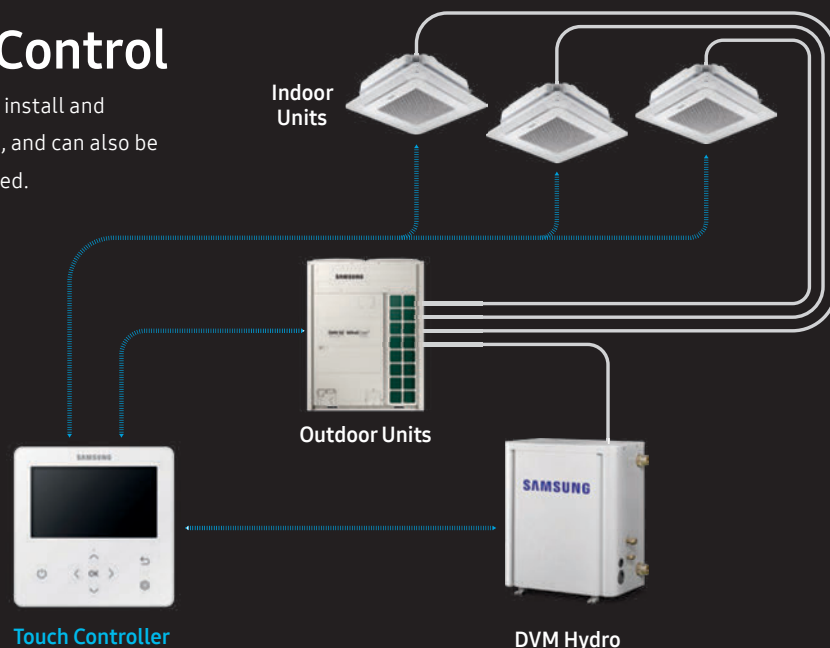

Specifications

Hydro Unit (R410A)

- Production of low temperature hot water and chilled water.
- Hot water production to a maximum temperature of 50°C/80°C (HT models).
- Two-Way control: leaving water temperature and room temperature control.
- Connection to low temperature radiators and AHU water coils.
- Hot water production for domestic hot water use.
- Connectable to Heat Recovery DVM S systems (excluding 50 kW hydro unit).



Model (HE)			AM160FNBDEH/EU	AM320FNBDEH/EU	AM500FNBDEH/EU
Power Supply	Φ, #, V, Hz		1Φ, 2, 220-240 V, 50 Hz	1Φ, 2, 220-240 V, 50 Hz	1Φ, 2, 220-240 V, 50 Hz
Performance					
Capacity (Nominal)	Cooling	kW	14.0	28,0	44.8
	Heating	kW	16.0	31.5	50.4
Power					
Power Input (Nominal)	Cooling	W	10	10	10
	Heating	W	10	10	10
Current Input (Nominal)	Cooling	A	0.05	0.05	0.05
	Heating	A	0.05	0.05	0.05
MCA (Including External Contact)		A	2.2	2.2	2.2
MFA		A	2.75	2.75	2.75
Heat Exchange					
Type		-	PHE	PHE	PHE
Quantity		ea	1	1	1
Pipe Size		Ø, inch	PT1 (25A)	PT1 (25A)	PT1 1/4 (32A)
Water Flow Rate		l/min	48	92	150
Flow Switch		l/min	20	30	50
Piping Connections					
Liquid Pipe		Ø, mm	9.52	9.52	12.70
		Ø, inch	3/8	3/8	1/2
Gas Pipe		Ø, mm	15.88	22.20	28.58
		Ø, inch	5/8	7/8	1 1/8
Field Wiring					
Power Source Wire (L<10 m, Single Installation)		mm ²	2.5	2.5	2.5
Transmission Cable		mm ²	0.75-1.50	0.75-1.50	0.75-1.50
Refrigerant					
Type		-	R410A (Fluorinated greenhouse gas, GWP=2,088)		
Control Method		-	EEV	EEV	EEV
Sound					
Sound Pressure ¹		dB(A)	27	28	31
Sound Power		dB(A)	54	56	59
Dimensions					
Net Weight		kg	29.0	33.0	40.0
Net Dimensions (W × H × D)		mm	518 x 627 x 330	518 x 627 x 330	518 x 627 x 330
Operating					
Ambient	Cooling	°C	-5.0-48.0	-5.0-48.0	-5.0-48.0
	Heating	°C	-20.0-35.0	-20.0-35.0	-20.0-35.0
	Hot Water (Main Cooling, HR)	°C	-20.0-35.0 (43.0)	-20.0-35.0 (43.0)	-20.0-35.0 (43.0)
Leaving Water	Cooling	°C	5.0-30.0	5.0-30.0	5.0-30.0
	Heating	°C	20.0-50.0	20.0-50.0	20.0-50.0

Accessories



Wired Remote Controller

Wired Remote Controller

MWR-WW00N

MWR-WG01*N

¹ Sound pressure level is obtained in an anechoic room. Sound pressure level is a relative value, depending on the distance and acoustic environment. Sound pressure level may differ depending on operation conditions.



Model (HT)			AM160TNBFEB/EU	AM160TNBFG/EU	AM250TNBFEB/EU	AM250TNBFG/EU
Power Supply	Φ, #, V, Hz		1Φ, 2, 220-240 V, 50 Hz	3Φ, 4, 380-415 V, 50 Hz	1Φ, 2, 220-240 V, 50 Hz	3Φ, 4, 380-415 V, 50 Hz
Performance						
Capacity (Nominal)	Cooling	kW	-	-	-	-
	Heating	kW	16	16	25	25
Power						
Power Input (Nominal)	Cooling	W	-	-	-	-
	Heating	W	3.1	3.1	5.0	5.0
Current Input (Nominal)	Cooling	A	-	-	-	-
	Heating	A	14.30	4.85	23.10	7.85
MCA (Including External Contact)		A	18.0	16.1	30.0	16.1
MFA		A	25	20	40	20
Heat Exchanger						
Type		-	PHE	PHE	PHE	PHE
Quantity		ea	2	2	2	2
Pipe Size		Ø, inch	PT1 (25A)	PT1 (25A)	PT1 (25A)	PT1 (25A)
Water Flow Rate		l/min	23	23	36	36
Flow Switch		l/min	12	12	12	12
Piping Connections						
Liquid Pipe		Ø, mm	9.52	9.52	9.52	9.52
		Ø, inch	3/8	3/8	3/8	3/8
Gas Pipe		Ø, mm	15.88	15.88	15.88	15.88
		Ø, inch	5/8	5/8	5/8	5/8
Field Wiring						
Power Source Wire (L<10 m, Single Installation)		mm ²	4	2.5	4	2.5
Transmission Cable		mm ²	0.75-1.50	0.75-1.50	0.75-1.50	0.75-1.50
Refrigerant						
Type		-	R134A (Fluorinated greenhouse gas, GWP=1,430)			
Control Method		-	EEV	EEV	EEV	EEV
Factory Charging		kg / tCO ₂ e	2.15/3.07	2.15/3.07	2.15/3.07	2.15/3.07
Sound						
Sound Pressure ¹		dB(A)	42	42	42	42
Sound Power		dB(A)	60	60	61	61
Dimensions						
Net Weight		kg	105.0	103.5	105.0	103.5
Net Dimensions (W × H × D)		mm	518 x 1,210 x 330	518 x 1,210 x 330	518 x 1,210 x 330	518 x 1,210 x 330
Operating Temperature Range						
Ambient	Cooling	°C	-	-	-	-
	Heating	°C	-20-43	-20-43	-20-43	-20-43
	Hot Water (Main Cooling, HR)	°C	-20-43	-20-43	-20-43	-20-43
Leaving Water	Heating	°C	25-80	25-80	25-80	25-80

Specifications

Mode Control Unit (MCU, R410A)

- Enable simultaneous heating and cooling for DVM Heat Recovery model.



Model		MCU-R4NEKON	MCU-S6NEK3N
Type		HR Changer	MCU
Power Supply	Φ, #, V, Hz	1Φ, 220-240 V, 50/60 Hz	1Φ, 220-240 V, 50/60 Hz
Mode		Heat Recovery	Heat Recovery
Max. number of indoor units	ea	12	18
Max. indoor units per port	ea	3	3
Number of ports	ea	4	6
Max. capacity of indoor units	kW	22.4	22.4
Max. capacity of indoor units per port	kW	5.6	5.6
Y-Joint	kW	14.0	14.0
Refrigerant			
Additional Refrigerant Charging	kg/unit	0.5	0.5
Piping Connections			
Outdoor Unit - Liquid Pipe	Ø, mm	9.52	9.52
	Ø, inch	3/8	3/8
Gas Pipe (Low Pressure)	Ø, mm	19.05	19.05
	Ø, inch	3/4	3/4
Gas Pipe (High Pressure)	Ø, mm	15.88	15.88
	Ø, inch	5/8	5/8
Indoor Unit - Liquid Pipe	Ø, mm	6.35	6.35
	Ø, inch	1/4	1/4
Gas Pipe	Ø, mm	12.70	12.70
	Ø, inch	1/2	1/2
External Dim			
Net Weight	kg	21.3	24.3
Net Dimensions (W x H x D)	mm	728 x 199 x 469	728 x 199 x 469
Operating Temperature			
Cooling	°C	-5-48	-5-48
Heating	°C	-25-26	-25-26

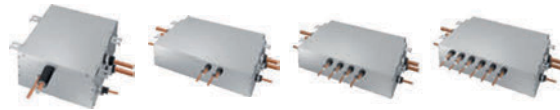

Model			MCU-S1NEK1N	MCU-S2NEK2N	MCU-S4NEK3N	MCU-S6NEK2N	MCU-S8NEK1N	MCU-S12NEK1N
Power Supply		Φ, #, V, Hz	1Φ, 2, 220-240 V, 50 Hz, 1Φ, 2, 208-230 V, 60 Hz					
Power								
Power Input (Nominal)	Cooling	W	19	25	40	55	80	110
	Heating	W	19	25	40	55	80	110
Current Input (Nominal)	Cooling	A	0.20	0.20	0.20	0.30	0.40	0.60
	Heating	A	0.20	0.20	0.20	0.30	0.40	0.60
MCA		A	2.0	2.0	2.0	2.0	2.0	2.0
MFA (MOP)		A	15.0	15.0	15.0	15.0	15.0	15.0
Max. number of connectable indoor units		ea	8	16	32	32	64	64
Max. number of connectable indoor units per branch		ea	8	8	8	8	8	8
Number of branches		ea	1	2	4	6	8	12
Max. capacity of connectable indoor units		kW	16.0	32.0	61.6	61.6	85.0	85.0
Max. capacity of connectable indoor units per branch		kW	16.0	16.0	16.0	16.0	16.0	16.0
Y-Joint		kW	-	32.0	32.0	32.0	32.0	32.0
Field Wiring								
Power Source Wire		mm ²	2.5	2.5	2.5	2.5	2.5	2.5
Transmission Cable		mm ²	0.75-1.50	0.75-1.50	0.75-1.50	0.75-1.50	0.75-1.50	0.75-1.50
Sound Pressure								
Stable Cooling Operation		dB(A)	33	34	36	36	38	38
Heating-to-Cooling Changeover		-	50	50	50	50	50	50
Additional Refrigerant Charging		kg/unit	0.5	0.5	0.5	0.5	1.0	1.0
Piping Connections								
Outdoor Unit	Liquid Pipe	Ø, mm	9.52	15.88	15.88	15.88	15.88	15.88
		Ø, inch	3/8	5/8	5/8	5/8	5/8	5/8
	Gas Pipe	Ø, mm	22.22	28.58	28.58	28.58	28.58	28.58
		Ø, inch	7/8	1 1/8	1 1/8	1 1/8	1 1/8	1 1/8
	Discharge Gas	Ø, mm	19.05	28.58	28.58	28.58	28.58	28.58
		Ø, inch	3/8	1 1/8	1 1/8	1 1/8	1 1/8	1 1/8
Indoor Unit	Liquid Pipe	Ø, mm	9.52	9.52	9.52	9.52	9.52	9.52
		Ø, inch	3/8	3/8	3/8	3/8	3/8	3/8
	Gas Pipe	Ø, mm	15.88	15.88	15.88	15.88	15.88	15.88
		Ø, inch	5/8	5/8	5/8	5/8	5/8	5/8
External Dimensions								
Net Weight		kg	11.0	21.0	24.5	28.5	88.6	101.9
Net Dimensions (W x H x D)		mm	338 x 199 x 409	728 x 199 x 469	728 x 199 x 469	728 x 199 x 469	980 x 298 x 469	980 x 298 x 469
Operation Limit								
Cooling		°C (°F)	-15-48 (5-118.4)	-15-48 (5-118.4)	-15-48 (5-118.4)	-15-48 (5-118.4)	-15-48 (5-118.4)	-15-48 (5-118.4)
Heating		°C (°F)	-25-24 (-13-75.2)	-25-24 (-13-75.2)	-25-24 (-13-75.2)	-25-24 (-13-75.2)	-25-24 (-13-75.2)	-25-24 (-13-75.2)



Air Handling Unit (AHU) Kit

Connect to third-party air handling units

The Samsung AHU kit allows the connection of DVM outdoor units to third-party air handling units (AHUs)¹. With this kit you can supply heating or cooling to a DX coil in the AHU. This is a cost-efficient and effective way to provide fresh air to the building at the correct temperature. The unit improves performance and efficiency and is cost-effective.

Features include:

- IP54 waterproof certification (for MXD type AHU kit only)
- Variable capacity
- 2.5 HP–40 HP
- Simple BMS application (0–10 V, MXD-K/X Series)
- Discharge air temperature control and outdoor capacity control

¹ Please contact your local Samsung representative for more information.

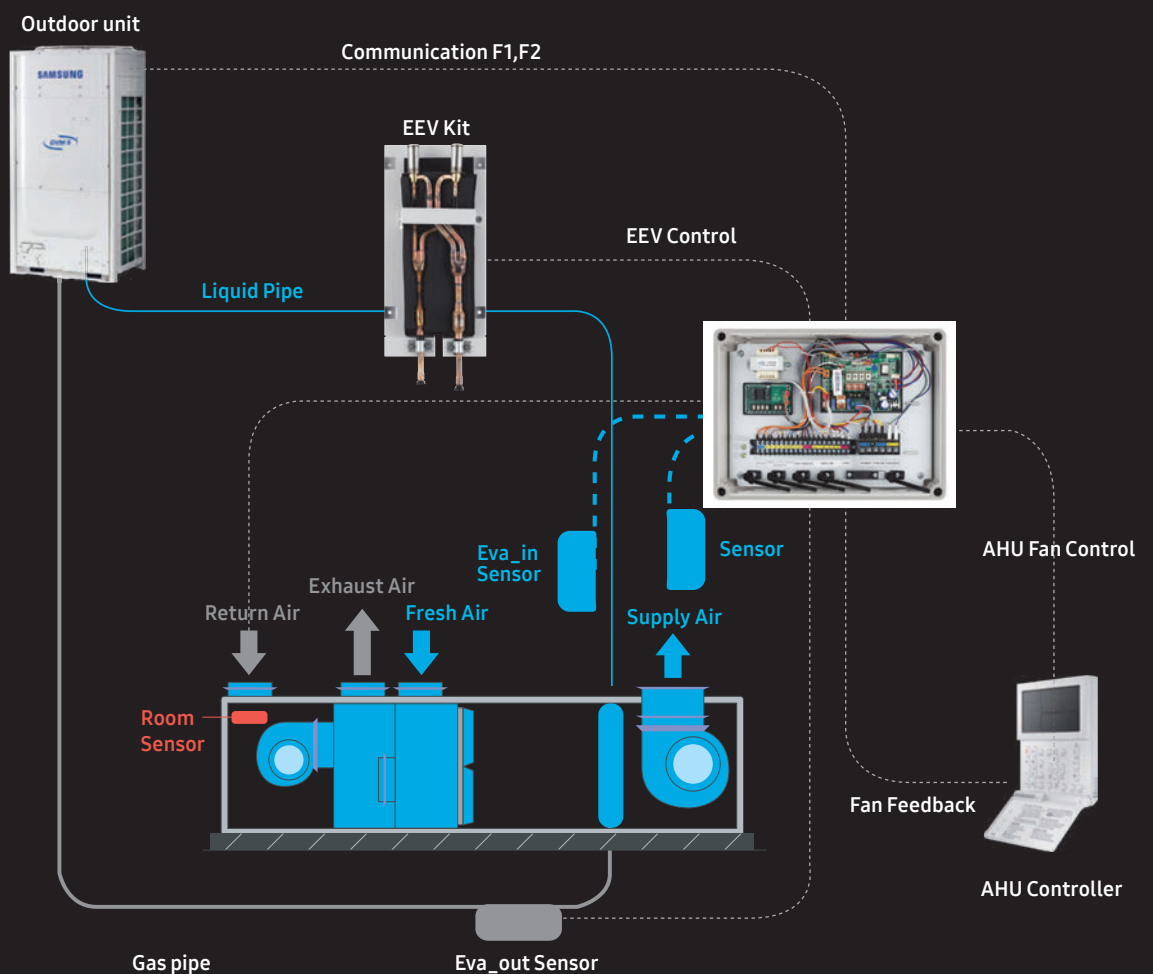

Specifications

AHU Kit for Outdoor Unit (R410A)

- Provide the benefits of the AHU and DVM systems at the same time.
- Centralised air conditioning system.
- The AHU kit can provide cooling or heating in one package.



Model			AHU Kit		
			MXD-K025AN	MXD-K050AN	MXD-K075AN
Connectable Outdoor			HP/HR	HP/HR	HP/HR
Power Supply	Φ, #, V, Hz		1Φ, 2, 220–240 V, 50/60 Hz	1Φ, 2, 220–240 V, 50/60 Hz	1Φ, 2, 220–240 V, 50/60 Hz
Design Recommendation					
AHU Capacity Allowance	Max.	kW	8.8	17.5	24.9
		MBH	30	60	85
	Min.	kW	6.3	12.6	18.9
		MBH	21.6	43.2	64.8
AHU Internal Heat Exchanger Volume Allowance	Max.	cm³	2,000	4,000	6,000
	Min.	cm³	1,200	2,400	4,100
Piping Connections (EEV Kit)					
High pressure pipe from outdoor unit		Ø, mm	9.52	9.52	9.52
		Ø, inch	3/8	3/8	3/8
High pressure pipe to AHU		Ø, mm	9.52	9.52	9.52
		Ø, inch	3/8	3/8	3/8
Sensor					
EVA. IN		Type/Φ	103HW/6Φ	103HW/6Φ	103HW/6Φ
		m/mm²	10 m/2*0.75 mm ²	10 m/2*0.75 mm ²	10 m/2*0.75 mm ²
EVA. OUT		Type/Φ	103HW/7Φ	103HW/7Φ	103HW/7Φ
		m/mm²	10 m/2*0.75 mm ²	10 m/2*0.75 mm ²	10 m/2*0.75 mm ²
Room		Type/Φ	103HW/Moulding	103HW/Moulding	103HW/Moulding
		m/mm²	10 m/2*0.75 mm ²	10 m/2*0.75 mm ²	10 m/2*0.75 mm ²
Discharge		Type/Φ	103HW/7Φ	103HW/7Φ	103HW/7Φ
		m/mm²	10 m/2*0.75 mm ²	10 m/2*0.75 mm ²	10 m/2*0.75 mm ²
Refrigerant					
Type	-		R410A (Fluorinated greenhouse gas, GWP=2,088)		
EEV Kit					
Type	-		INCLUDED	INCLUDED	INCLUDED
EEV Wire Length		m	2	2	7
		ft	6.6	6.6	23.0
External Dimensions					
EEV Kit	(W x H x D)	mm	415 x 102 x 170	415 x 102 x 170	415 x 102 x 170
Control Box	(W x H x D)	mm	380 x 130 x 280	380 x 130 x 280	380 x 130 x 280

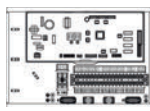

	AHU Kit	Control Kit	EEV Kit (Optional)
	MXD-K100AN	MCM-D201N	MXD-A64K100E
	HP/HR	HP	HP
	1Φ, 2, 220–240 V, 50/60 Hz	1Φ, 2, 220–240 V, 50/60 Hz	-
	35.0	35.0/70.0/105.0/140.0	35.0
	120	119/239/358/478	119
	25.2	25.2/50.4/75.6/100.8	25.2
	86.4	86.4/172.8/259.2/345.6	86.4
	8,000	8,000/16,000/24,000/32,000	8,000
	6,100	6,100/12,200/18,300/24,400	6,100
	9.52	-	12.70
	3/8	-	1/2
	9.52	-	12.70
	3/8	-	1/2
	103HW/6Φ	103HW/6Φ	-
	10 m/2*0.75 mm ²	7 m/2*0.75 mm ²	-
	103HW/7Φ	103HW/7Φ	-
	10 m/2*0.75 mm ²	7 m/2*0.75 mm ²	-
	103HW/Moulding	PT1000Ω/4–20 mA Field Supply	-
	10 m/2*0.75 mm ²	-	-
	103HW/7Φ	PT1000Ω/4–20 mA Field Supply	-
	10 m/2*0.75 mm ²	-	-
	R410A (Fluorinated greenhouse gas, GWP=2,088)		
	INCLUDED	NOT INCLUDED	-
	7	-	7
	23.0	-	23.0
	415 x 102 x 170	-	Accessory for MCM-D201N, ordered separately (1 per 10HP)
	380 x 130 x 280	385 x 53 x 275	-

Dimensional drawings

DVM S Mini Heat Pump

AM040DXMDKG/EU, AM050DXMDKG/EU, AM060DXMDKG/EU, AM040DXMDNG/EU, AM050DXMDNG/EU, AM060DXMDNG/EU

Units: mm [inches]

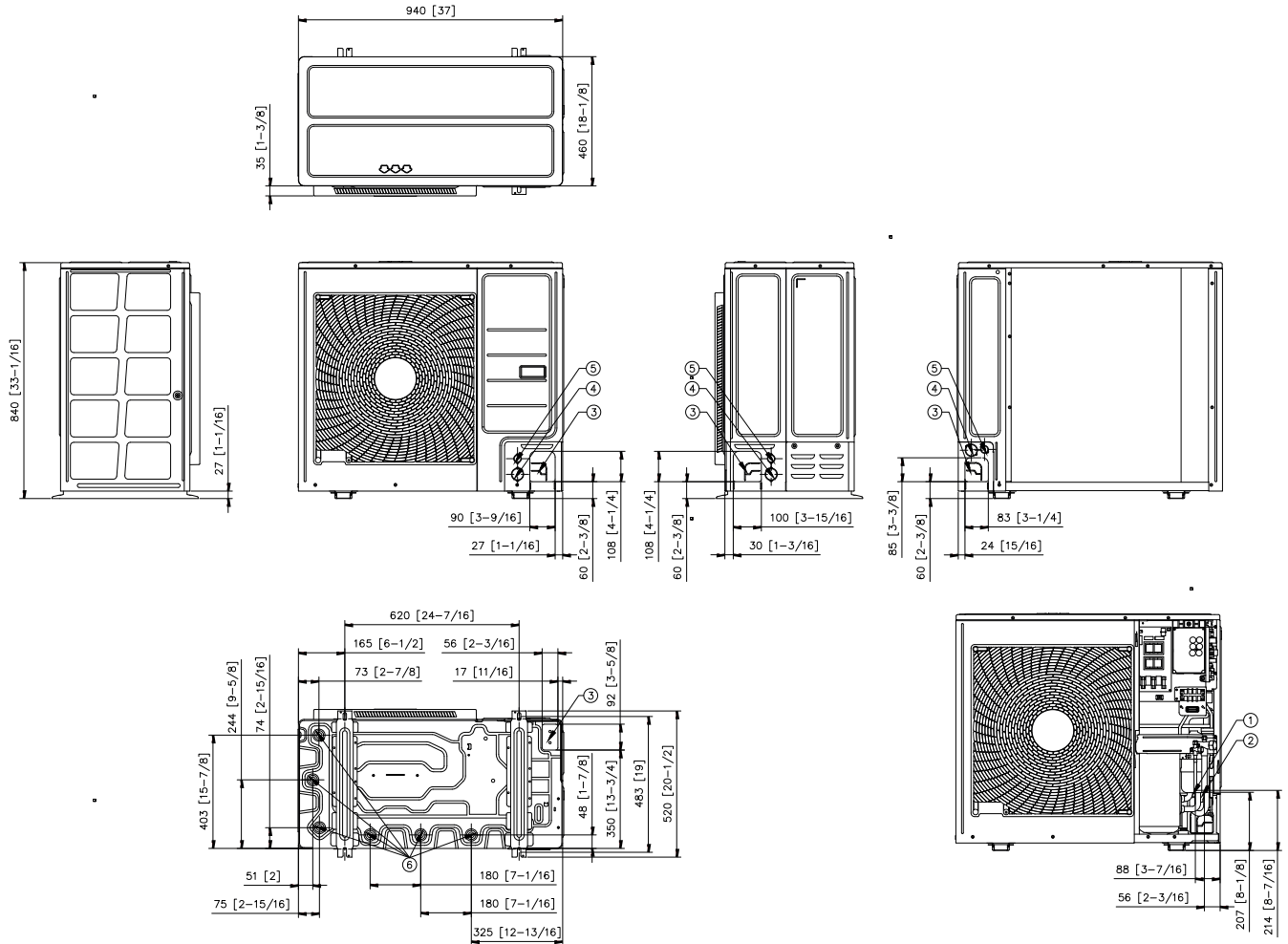

NO	Name	Description	
		AM040DXMD*G/EU, AM050DXMD*G/EU	AM060DXMD*G/EU
1	Refrigerant liquid pipe	Ø9.52 (Ø3/8)	
2	Refrigerant gas pipe	Ø15.88 (Ø5/8)	Ø19.05 (Ø3/4)
3	Knock-out hole for pipe intake	Front/Side/Rear/Bottom	
4	Power wiring conduits	Front/Side/Rear, Ø34.00 (Ø1 3/8)	
5	Communication wiring conduits	Front/Side/Rear, Ø22.00 (Ø7/8)	
6	Drain holes	Connect with the provided drain plug.	

Dimensional drawings ^{1/2}

DVM S Heat Pump (R410A)

AM040BXMDEH/EU, AM050BXMDEH/EU

Units: mm [inches]

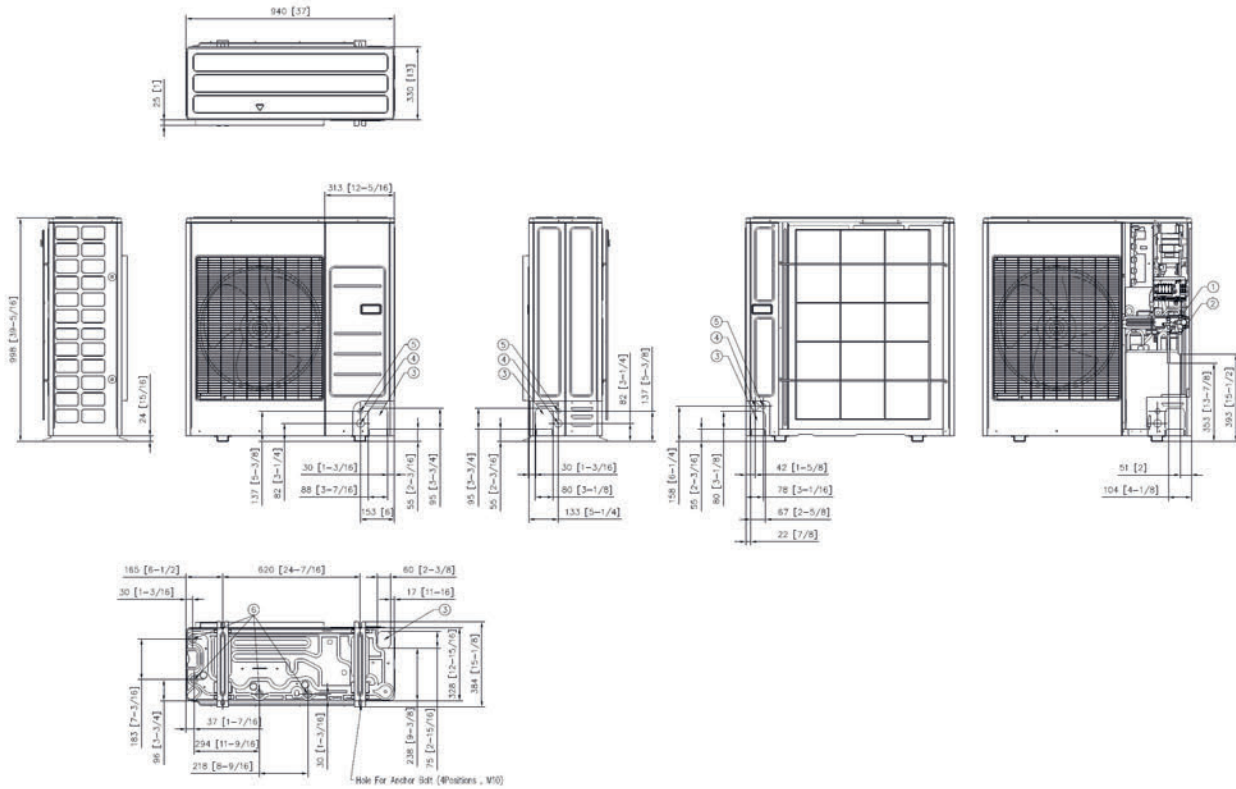

NO	Name	Description
4/5 hp		
1	Refrigerant liquid pipe	Ø9.52 (Ø3/8)
2	Refrigerant gas pipe	Ø15.88 (Ø5/8)
3	Knock-out hole for pipe intake	Front/Side/Rear/Bottom
4	Power wiring conduits	Front/Side/Rear, Ø34.00 (Ø1 3/8)
5	Communication wiring conduits	Front/Side/Rear, Ø22.00 (Ø7/8)
6	Drain holes	Connect with the provided drain plug.

Dimensional drawings ^{2/2}

DVM S Heat Pump (R410A)

AM080BXMWGH/EU, AM080BXMWGH/EU

Units: mm [inches]

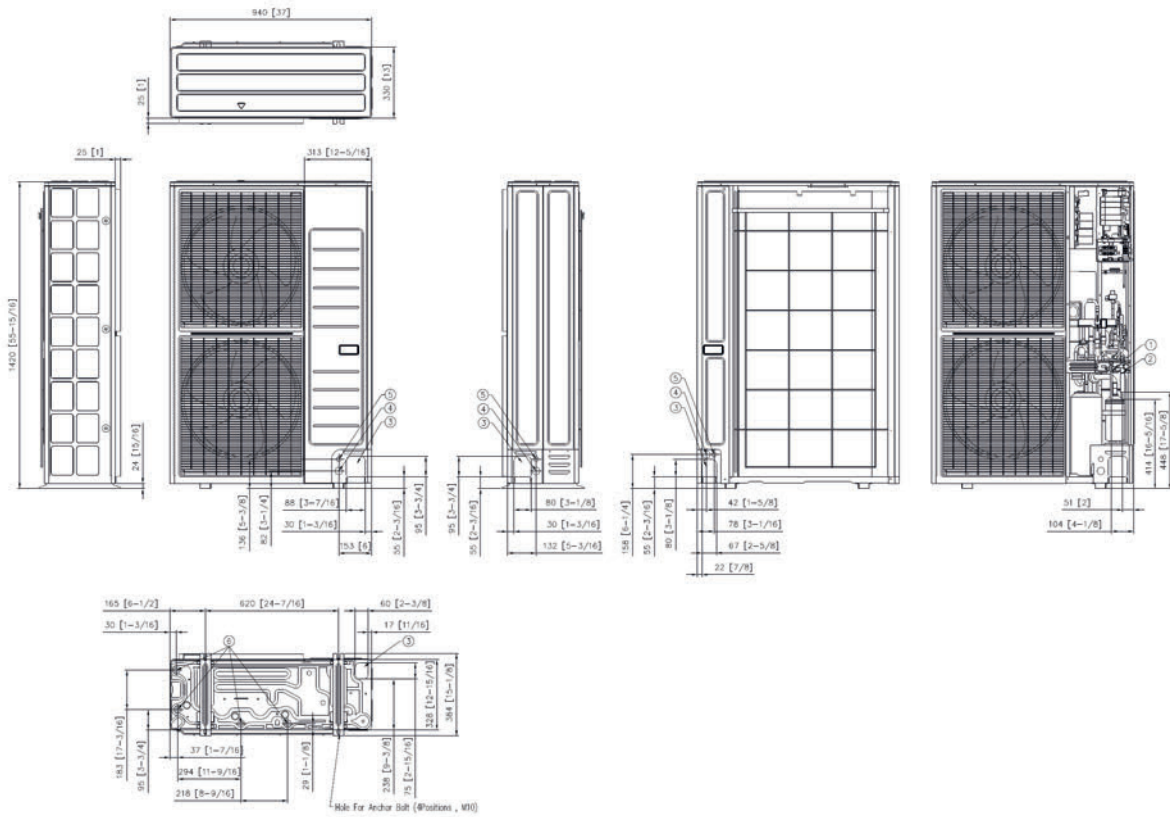

NO	Name	Description
8 hp		
1	Refrigerant gas pipe	Ø19.05 (Ø3/4)
2	Refrigerant liquid pipe	Ø9.52 (Ø3/8)
3	Knock-out hole for pipe intake	Front/Side/Rear/Bottom
4	Power wiring conduits	Front/Side/Rear, Ø34.00 (Ø1 3/8)
5	Communication wiring conduits	Front/Side/Rear, Ø22.00 (Ø7/8)
6	Drain holes	Connect with the provided drain plug.

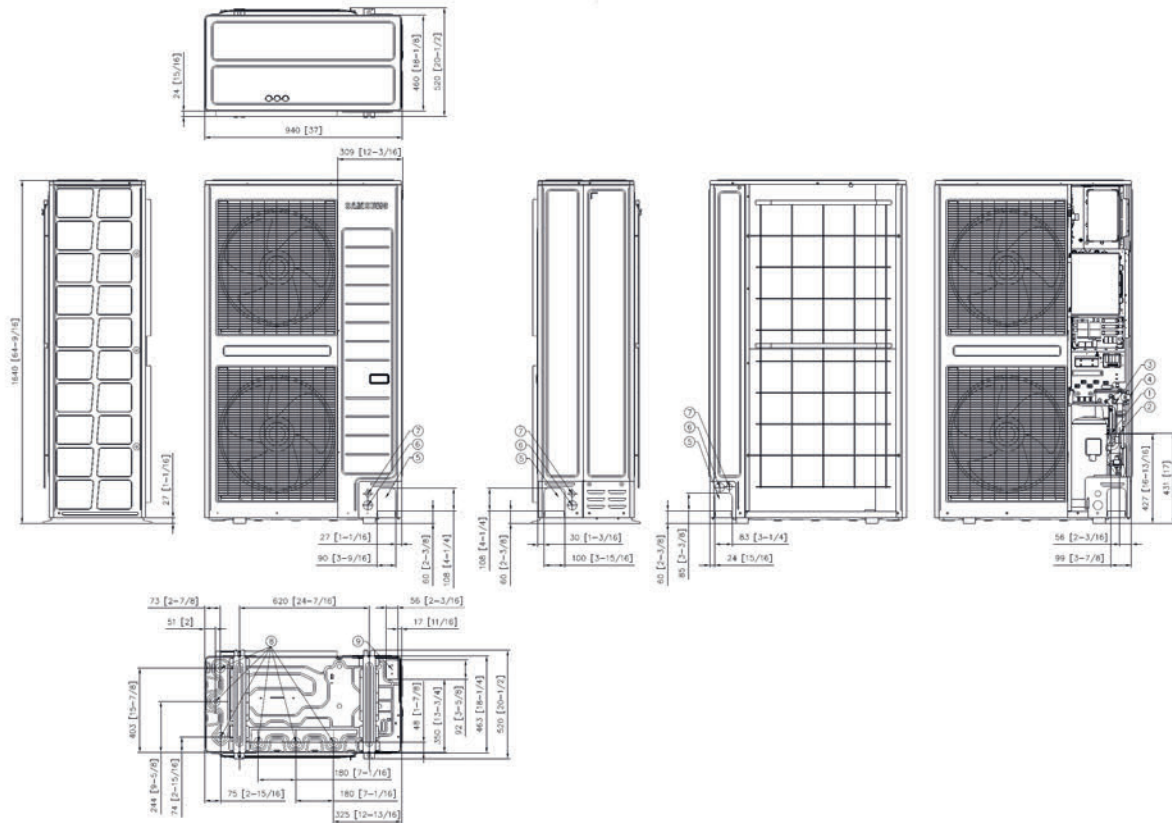

NO	Name	Description	
		10 hp	12 hp
1	Refrigerant liquid pipe	Ø9.52 (Ø3/8)	Ø12.70 (Ø1/2)
2	Refrigerant gas pipe	Ø22.28 (Ø5/8)	Ø28.58 (Ø3/4)
3	Service valve (gas)		
4	Service valve (liquid)		
5	Knock-out hole for pipe intake		Front/Side/Rear
6	Power wiring conduits		Front/Side/Rear, Ø44 (Ø1 3/4)
7	Communication wiring conduits		Front/Side/Rear, Ø28 (Ø1 1/8)
8	Drain holes		Connect with the provided drain plug.
9	Knock-out hole for pipe intake		Bottom

Dimensional drawings

DVM S (R410A) Heat Recovery (With Heat Recovery Changer Kit)

AM040BXMDER/EU, AM050BXMDER/EU, AM060BXMDER/EU

Units: mm [inches]

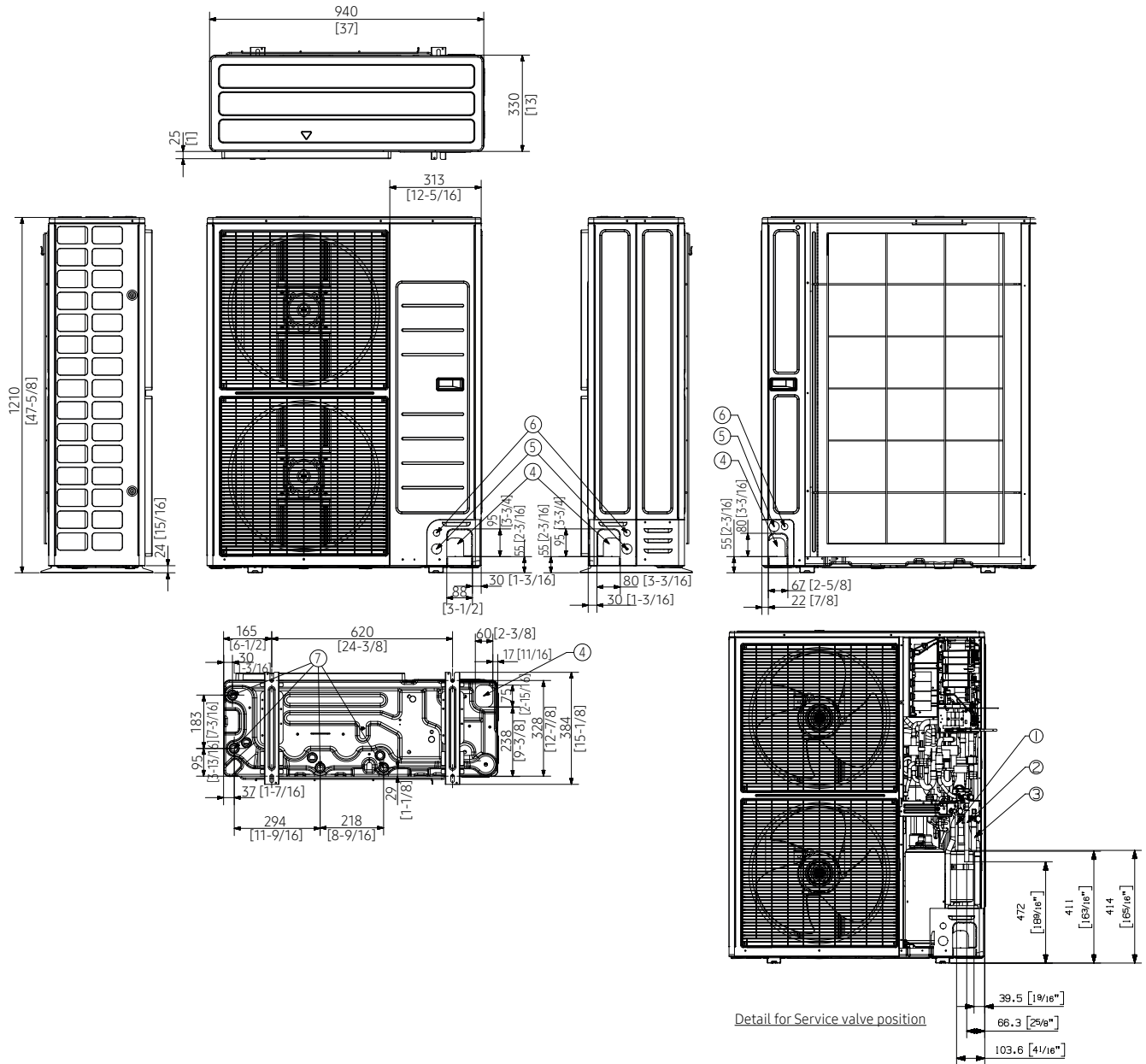

NO	Name	Description
1	Refrigerant liquid pipe	Ø9.52 (Ø3/8)
2	Refrigerant High pressure Gas pipe	Ø15.88 (Ø5/8)
3	Refrigerant low pressure gas pipe	Ø19.05 (Ø3/4)
4	Knock-out hole for pipe intake	Front/Side/Rear/Bottom
5	Power wiring conduits	Front/Side/Rear, Ø34.00 (Ø1 3/8)
6	Communication wiring conduits	Front/Side/Rear, Ø22.00 (Ø7/8)
7	Drain holes	Connect with the provided drain plug.



Dimensional drawings

DVM S2 Essential Heat Pump (2-Pipe, R410A)

AM100/120/140AXVDGH/EU

Units: mm [inches]

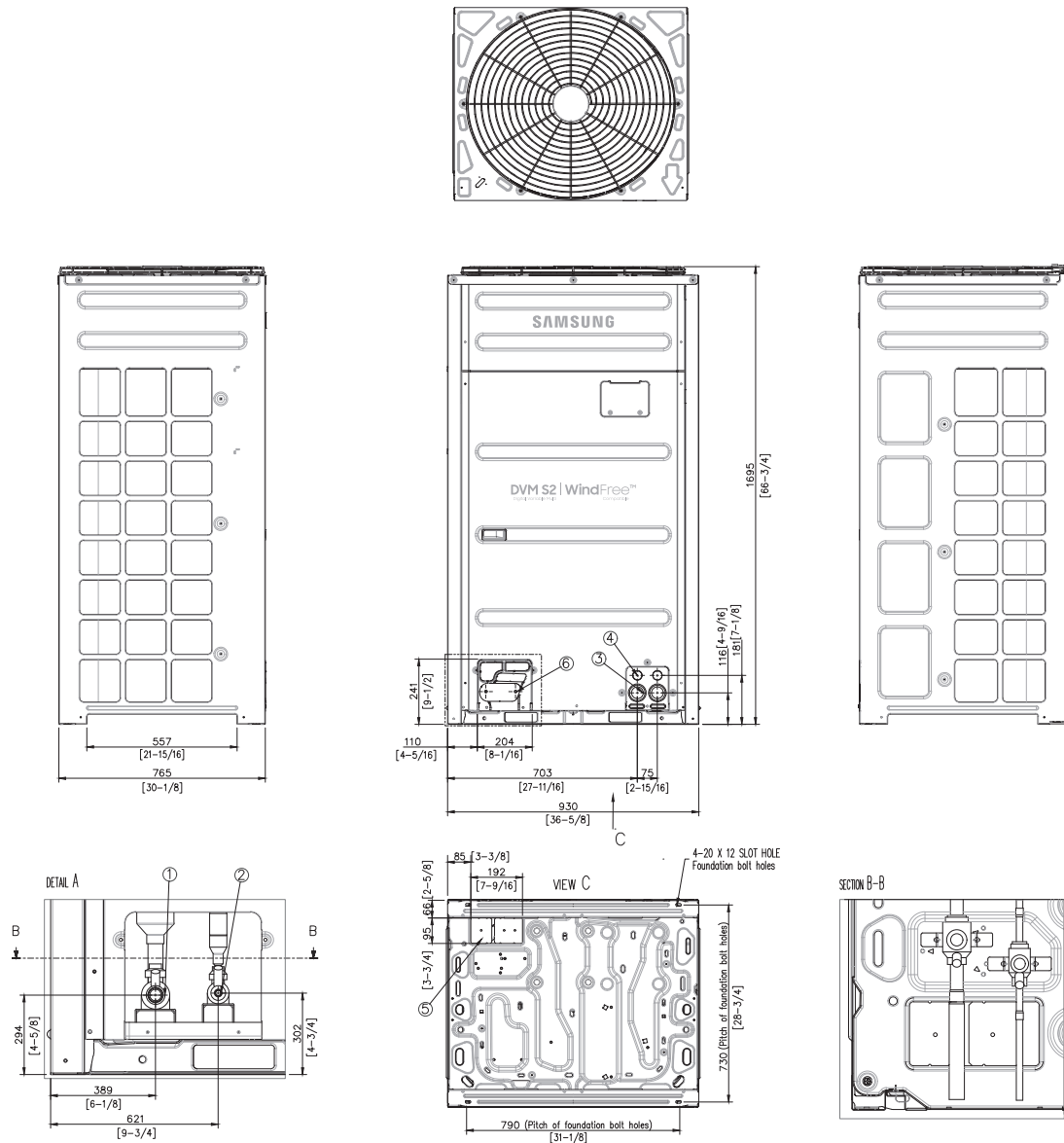

NO	Name	Description
1	Gas Ref.pipe	See NOTE 4.
2	Liquid Ref.pipe	See NOTE 4.
3	Power wiring conduit	Ø44
4	Communication wiring conduit	Ø34
5	Knock-out Hole for Ref.Piping (bottom)	
6	Knock-out Hole for Ref.Piping (front)	

Note:
 1. Detail A and SECTION B-B indicate the dimension after fixing the attached piping.
 2. Item 3-6: Knock-out hole.
 3. View C indicate the dimension of knock-out hole (bottom).
 4. Pipe [Ø, mm(inch)]: Brazing connection.

HP	Liquid pipe	Gas pipe
8	9.52(3/8)	19.05(3/4)
10	9.52(3/8)	22.22(7/8)
12	12.70(1/2)	28.58(1-1/8)
14	12.70(1/2)	28.58(1-1/8)
16	12.70(1/2)	28.58(1-1/8)
18	15.88(5/8)	28.58(1-1/8)
20	15.88(5/8)	28.58(1-1/8)
22	15.88(5/8)	28.58(1-1/8)
24	15.88(5/8)	34.92(1-3/8)
26	19.05(3/4)	34.92(1-3/8)

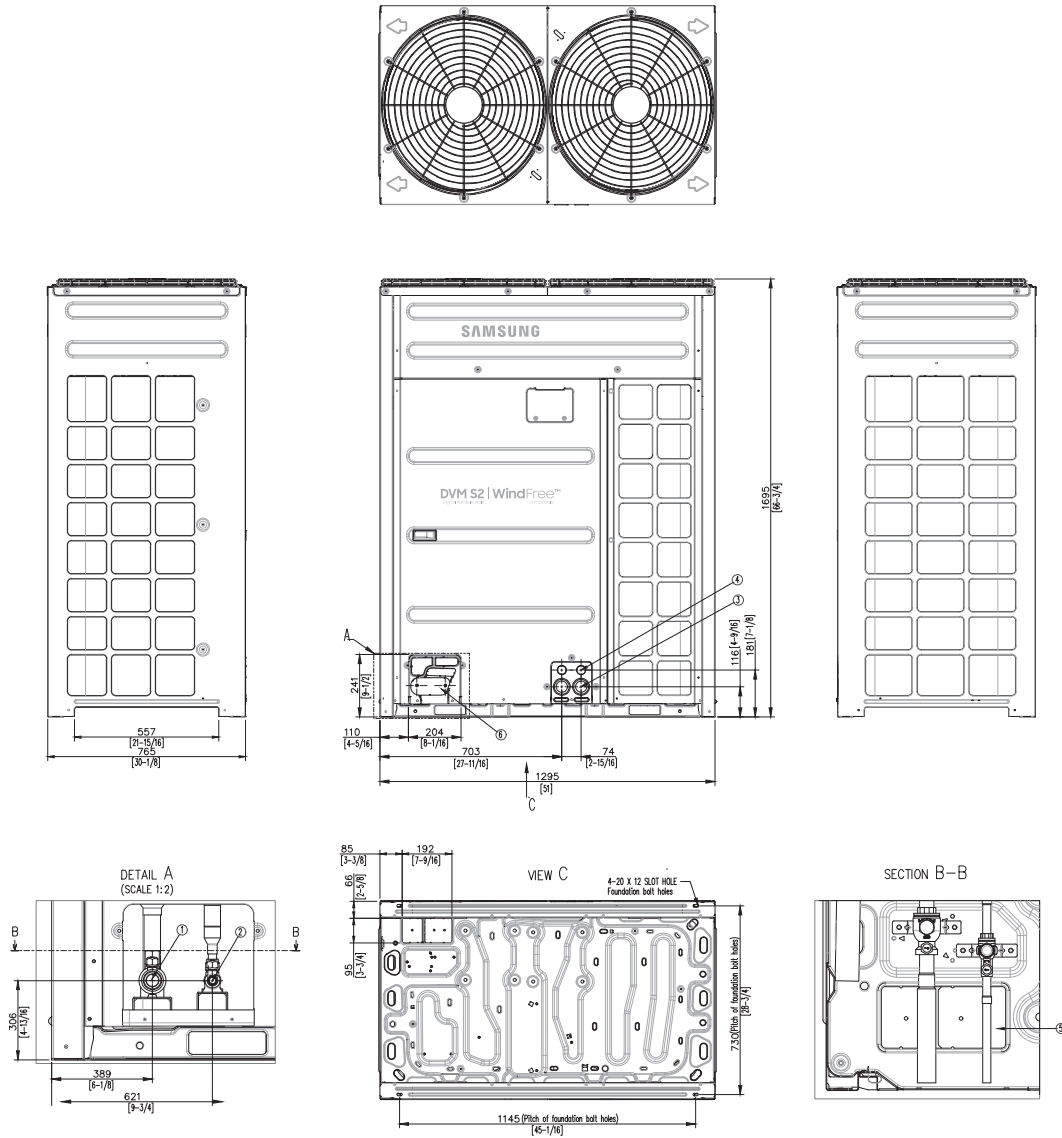

NO	Name	Description
1	Gas Ref.pipe	See NOTE 4.
2	Liquid Ref.pipe	See NOTE 4.
3	Power wiring conduit	Ø44
4	Communication wiring conduit	Ø34
5	Knock-out Hole for Ref.Piping (bottom)	
6	Knock-out Hole for Ref.Piping (front)	

HP	Liquid pipe	Gas pipe
8	9.52(3/8)	19.05(3/4)
10	9.52(3/8)	22.22(7/8)
12	12.70(1/2)	28.58(1-1/8)
14	12.70(1/2)	28.58(1-1/8)
16	12.70(1/2)	28.58(1-1/8)
18	15.88(5/8)	28.58(1-1/8)
20	15.88(5/8)	28.58(1-1/8)
22	15.88(5/8)	28.58(1-1/8)
24	15.88(5/8)	34.92(1-3/8)
26	19.05(3/4)	34.92(1-3/8)

Note:
 1. Detail A and SECTION B-B indicate the dimension after fixing the attached piping.
 2. Item 3-6: Knock-out hole.
 3. View C indicate the dimension of knock-out hole (bottom).
 4. Pipe [Ø, mm(inch)]: Brazing connection.

Dimensional drawings

DVM S2 Standard Heat Pump (2-Pipe, R410A)

AM080/100/120/140AXVAGH/EU

Units: mm [inches]

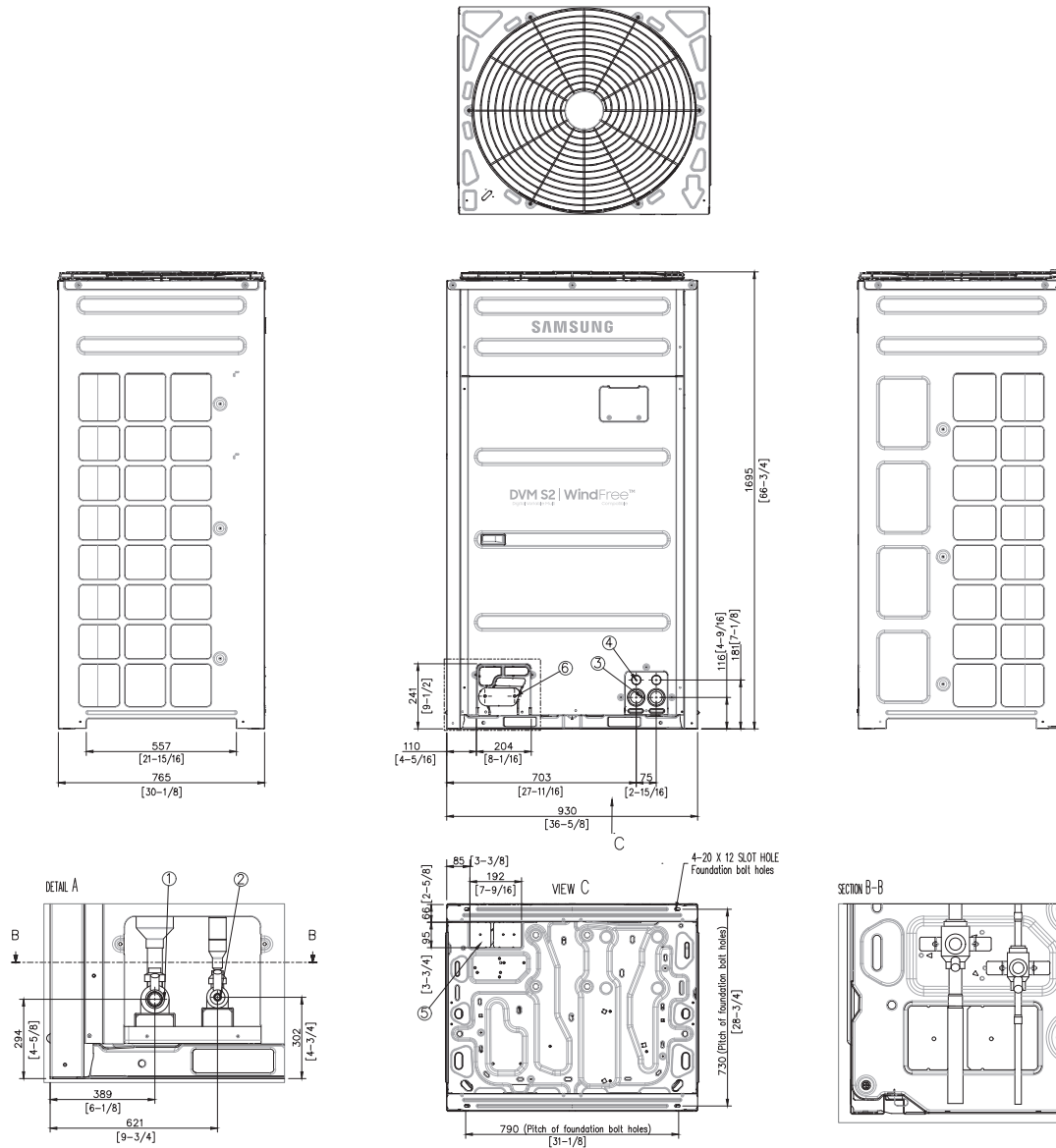

NO	Name	Description
1	Gas Ref.pipe	See NOTE 4.
2	Liquid Ref.pipe	See NOTE 4.
3	Power wiring conduit	Ø44
4	Communication wiring conduit	Ø34
5	Knock-out Hole for Ref.Piping (bottom)	
6	Knock-out Hole for Ref.Piping (front)	

HP	Liquid pipe	Gas pipe
8	9.52(3/8)	19.05(3/4)
10	9.52(3/8)	22.22(7/8)
12	12.70(1/2)	28.58(1-1/8)
14	12.70(1/2)	28.58(1-1/8)
16	12.70(1/2)	28.58(1-1/8)
18	15.88(5/8)	28.58(1-1/8)
20	15.88(5/8)	28.58(1-1/8)
22	15.88(5/8)	28.58(1-1/8)
24	15.88(5/8)	34.92(1-3/8)
26	19.05(3/4)	34.92(1-3/8)

Note:
 1. Detail A and SECTION B-B indicate the dimension after fixing the attached piping.
 2. Item 3-6: Knock-out hole.
 3. View C indicate the dimension of knock-out hole (bottom).
 4. Pipe [Ø, mm(inch)]: Brazing connection.

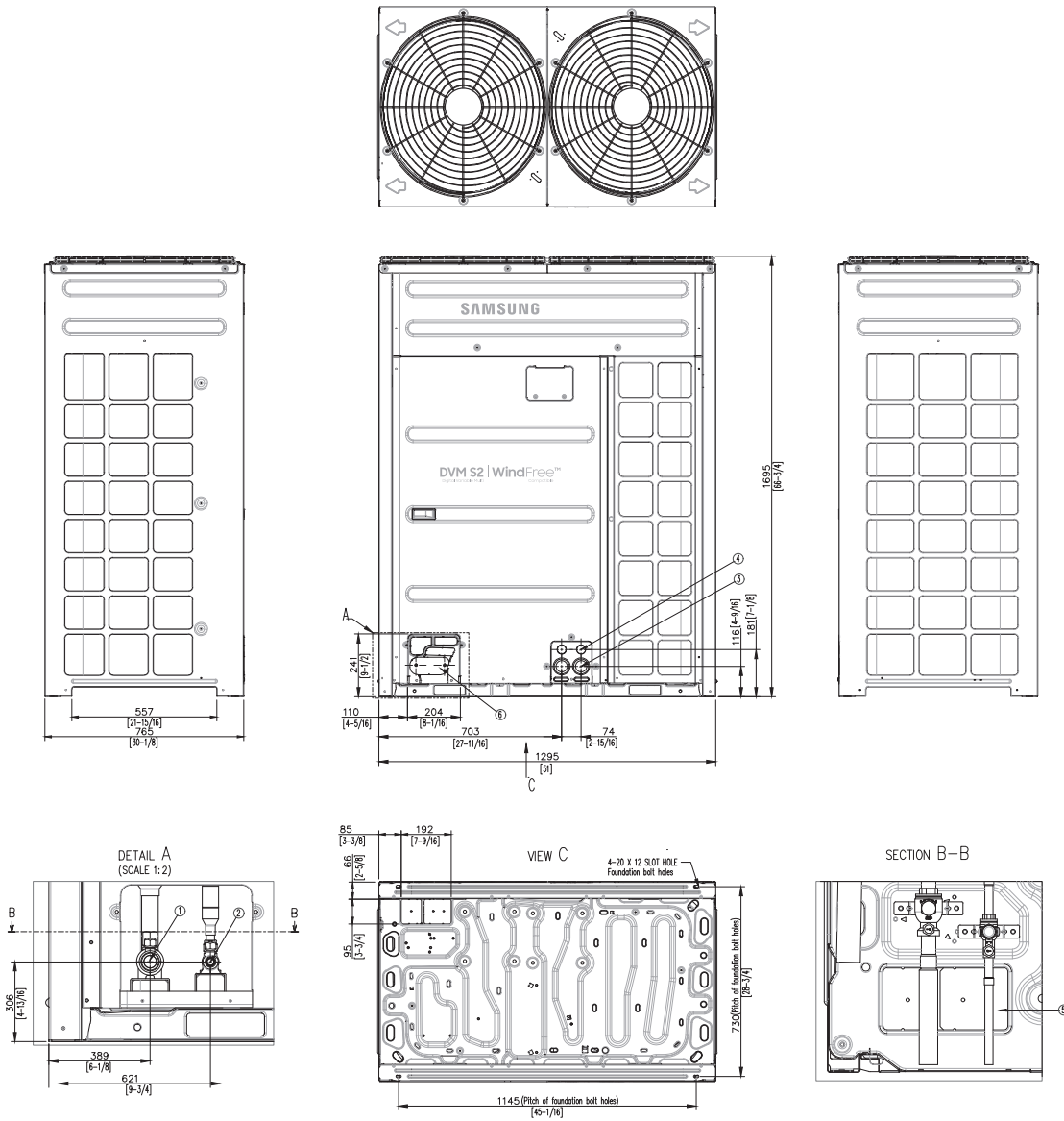

NO	Name	Description
1	Gas Ref.pipe	See NOTE 4.
2	Liquid Ref.pipe	See NOTE 4.
3	Power wiring conduit	Ø44
4	Communication wiring conduit	Ø34
5	Knock-out Hole for Ref.Piping (bottom)	
6	Knock-out Hole for Ref.Piping (front)	

HP	Liquid pipe	Gas pipe
8	9.52(3/8)	19.05(3/4)
10	9.52(3/8)	22.22(7/8)
12	12.70(1/2)	28.58(1-1/8)
14	12.70(1/2)	28.58(1-1/8)
16	12.70(1/2)	28.58(1-1/8)
18	15.88(5/8)	28.58(1-1/8)
20	15.88(5/8)	28.58(1-1/8)
22	15.88(5/8)	28.58(1-1/8)
24	15.88(5/8)	34.92(1-3/8)
26	19.05(3/4)	34.92(1-3/8)

Note:
 1. Detail A and SECTION B-B indicate the dimension after fixing the attached piping.
 2. Item 3-6: Knock-out hole.
 3. View C indicate the dimension of knock-out hole (bottom).
 4. Pipe [Ø, mm(inch)]: Brazing connection.

Dimensional drawings

DVM S2 High Efficiency Heat Pump (2-Pipe, R410A)

AM080/100/120AXVGGH/EU

Units: mm [inches]

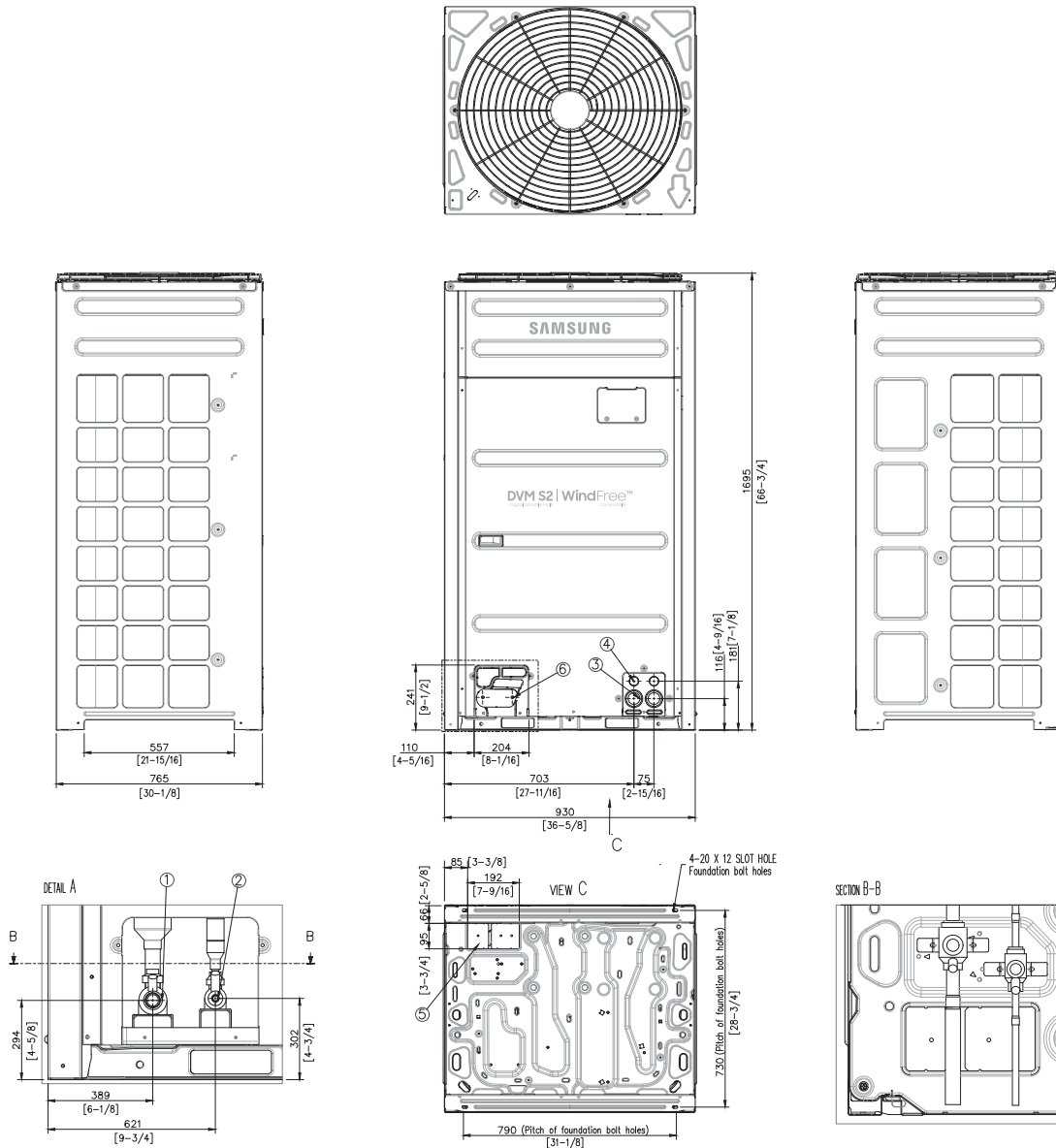

NO	Name	Description
1	Gas Ref.pipe	See NOTE 4.
2	Liquid Ref.pipe	See NOTE 4.
3	Power wiring conduit	Ø44
4	Communication wiring conduit	Ø34
5	Knock-out Hole for Ref.Piping (bottom)	
6	Knock-out Hole for Ref.Piping (front)	

Note:
 1. Detail A and SECTION B-B indicate the dimension after fixing the attached piping.
 2. Item 3-6: Knock-out hole.
 3. View C indicate the dimension of knock-out hole (bottom).
 4. Pipe [Ø, mm(inch)]: Brazing connection.

HP	Liquid pipe	Gas pipe
8	9.52(3/8)	19.05(3/4)
10	9.52(3/8)	22.22(7/8)
12	12.70(1/2)	28.58(1-1/8)
14	12.70(1/2)	28.58(1-1/8)
16	12.70(1/2)	28.58(1-1/8)
18	15.88(5/8)	28.58(1-1/8)
20	15.88(5/8)	28.58(1-1/8)
22	15.88(5/8)	28.58(1-1/8)
24	15.88(5/8)	34.92(1-3/8)
26	19.05(3/4)	34.92(1-3/8)

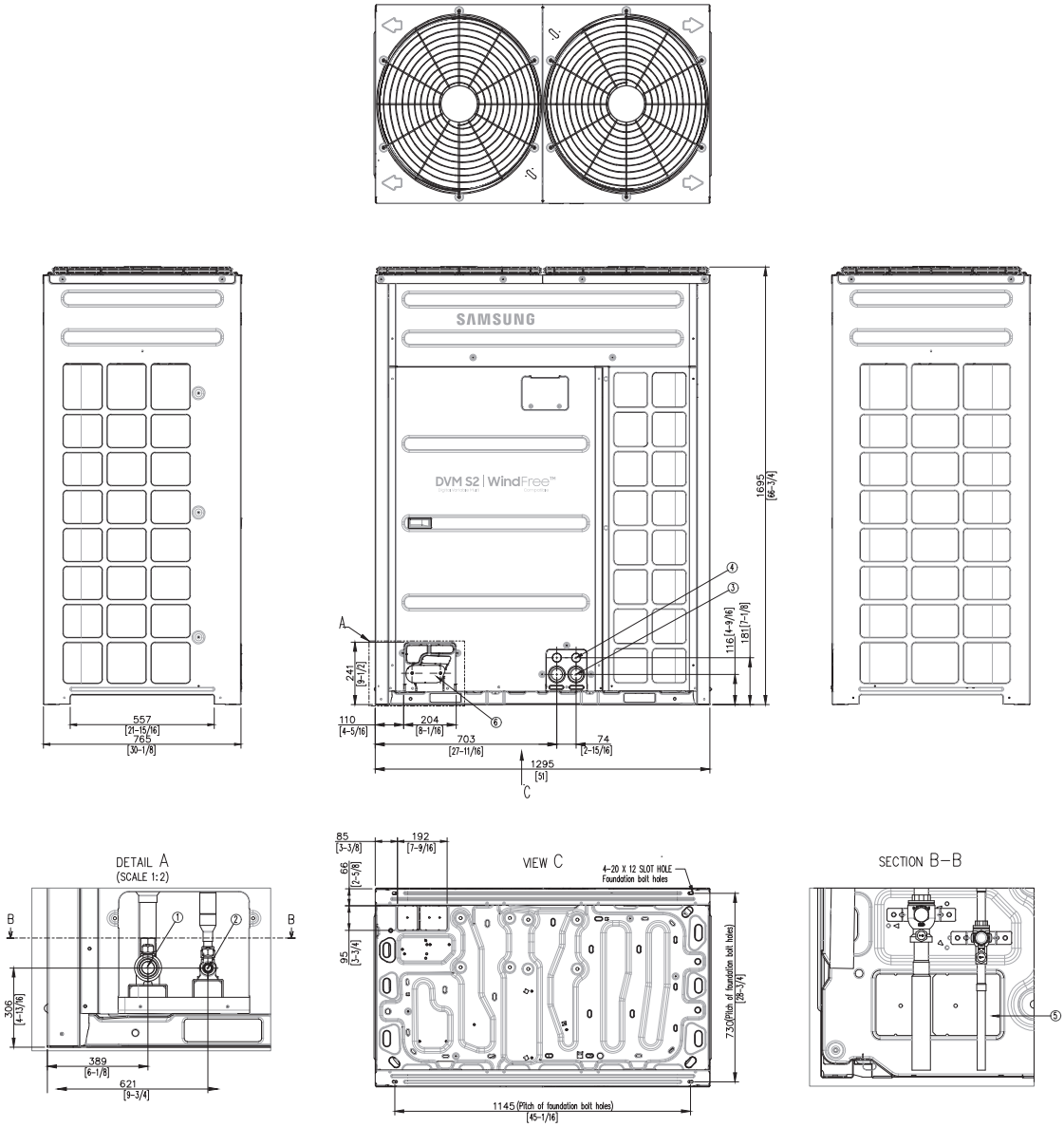

NO	Name	Description
1	Gas Ref.pipe	See NOTE 4.
2	Liquid Ref.pipe	See NOTE 4.
3	Power wiring conduit	Ø44
4	Communication wiring conduit	Ø34
5	Knock-out Hole for Ref.Piping (bottom)	
6	Knock-out Hole for Ref.Piping (front)	

HP	Liquid pipe	Gas pipe
8	9.52(3/8)	19.05(3/4)
10	9.52(3/8)	22.22(7/8)
12	12.70(1/2)	28.58(1-1/8)
14	12.70(1/2)	28.58(1-1/8)
16	12.70(1/2)	28.58(1-1/8)
18	15.88(5/8)	28.58(1-1/8)
20	15.88(5/8)	28.58(1-1/8)
22	15.88(5/8)	28.58(1-1/8)
24	15.88(5/8)	34.92(1-3/8)
26	19.05(3/4)	34.92(1-3/8)

Note:
 1. Detail A and SECTION B-B indicate the dimension after fixing the attached piping.
 2. Item 3-6: Knock-out hole.
 3. View C indicate the dimension of knock-out hole (bottom).
 4. Pipe [Ø, mm(inch)]: Brazing connection.

Dimensional drawings

DVM S2 High EER Heat Recovery (3-Pipe, R410A)

AM080/100/120AXVGGR/EU

Units: mm [inches]

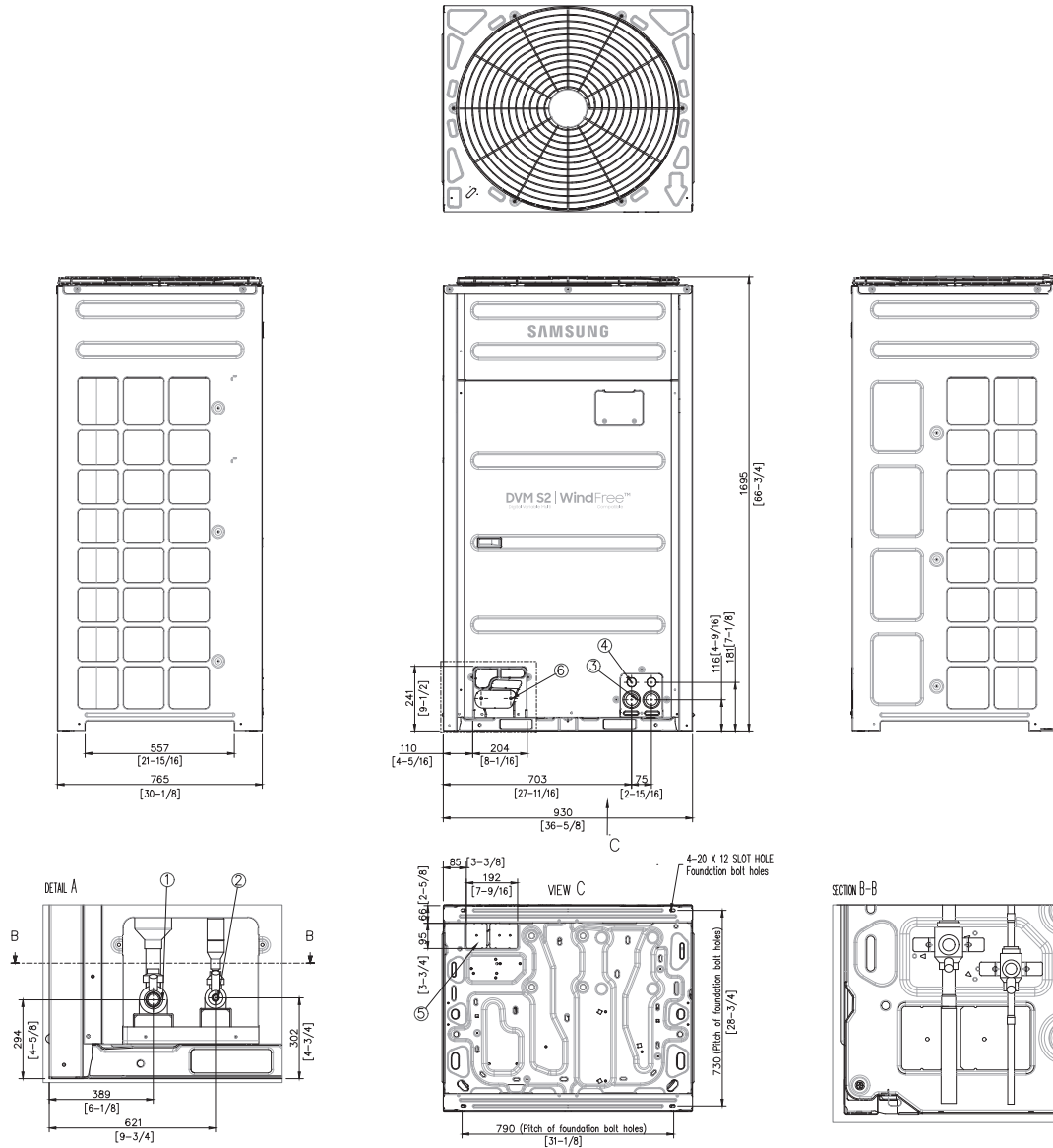

NO	Name	Description
1	Low Pressure Gas Ref.pipe	See NOTE 4.
2	High Pressure Ref.pipe	See NOTE 4.
3	Liquid Ref.pipe	See NOTE 4.
4	Power wiring conduit	Ø44
5	Communication wiring conduit	Ø34
6	Knock-out Hole for Ref.Piping (bottom)	
7	Knock-out Hole for Ref.Piping (front)	

Note:
 1. Detail A and SECTION B-B indicate the dimension after fixing the attached piping.
 2. Item 3-7: Knock-out hole.
 3. View C indicate the dimension of knock-out hole (bottom).
 4. Pipe [Ø, mm(inch)]: Brazing connection.

HP	Liquid pipe	Low Pressure Gas pipe	High Pressure Gas pipe
8	9.52(3/8)	19.05(3/4)	15.88(5/8)
10	9.52(3/8)	22.22(7/8)	19.05(3/4)
12	12.70(1/2)	28.58(1-1/8)	19.05(3/4)
14	12.70(1/2)	22.22(7/8)	22.22(7/8)
16	12.70(1/2)	28.58(1-1/8)	22.22(7/8)
18	15.88(5/8)	28.58(1-1/8)	22.22(7/8)
20	15.88(5/8)	28.58(1-1/8)	28.58(1-1/8)
22	15.88(5/8)	28.58(1-1/8)	28.58(1-1/8)
24	15.88(5/8)	34.92(1-3/8)	28.58(1-1/8)
26	19.05(3/4)	34.92(1-3/8)	28.58(1-1/8)

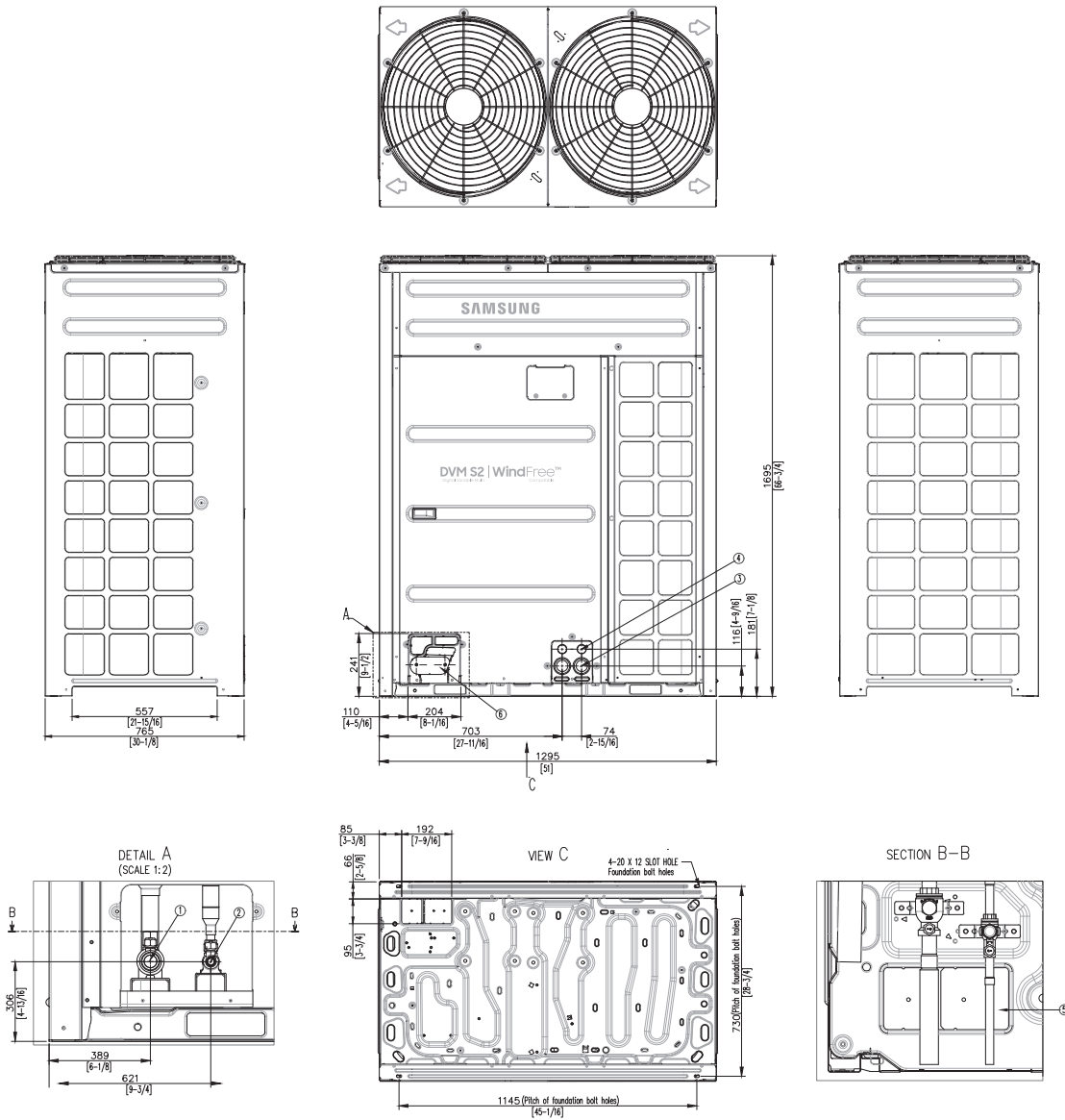

NO	Name	Description
1	Low Pressure Gas Ref.pipe	See NOTE 4.
2	High Pressure Ref.pipe	See NOTE 4.
3	Liquid Ref.pipe	See NOTE 4.
4	Power wiring conduit	Ø44
5	Communication wiring conduit	
6	Knock-out Hole for Ref.Piping (bottom)	
7	Knock-out Hole for Ref.Piping (front)	

HP	Liquid pipe	Low Pressure Gas pipe	High Pressure Gas pipe
8	9.52(3/8)	19.05(3/4)	15.88(5/8)
10	9.52(3/8)	22.22(7/8)	19.05(3/4)
12	12.70(1/2)	28.58(1-1/8)	19.05(3/4)
14	12.70(1/2)	28.58(1-1/8)	22.22(7/8)
16	12.70(1/2)	28.58(1-1/8)	22.22(7/8)
18	15.88(5/8)	28.58(1-1/8)	22.22(7/8)
20	15.88(5/8)	28.58(1-1/8)	28.58(1-1/8)
22	15.88(5/8)	28.58(1-1/8)	28.58(1-1/8)
24	15.88(5/8)	34.92(1-3/8)	28.58(1-1/8)
26	19.05(3/4)	34.92(1-3/8)	28.58(1-1/8)

Note:
 1. Detail A and SECTION B-B indicate the dimension after fixing the attached piping.
 2. Item 3-7: Knock-out hole
 3. View C indicate the dimension of knock-out hole (bottom)
 4. Pipe [Ø, mm(inch)]: Brazing connection

Dimensional drawings ^{1/2}

DVM S Water (R410A)

AM080/100/120MXWANR/EU

Units: mm [inches]

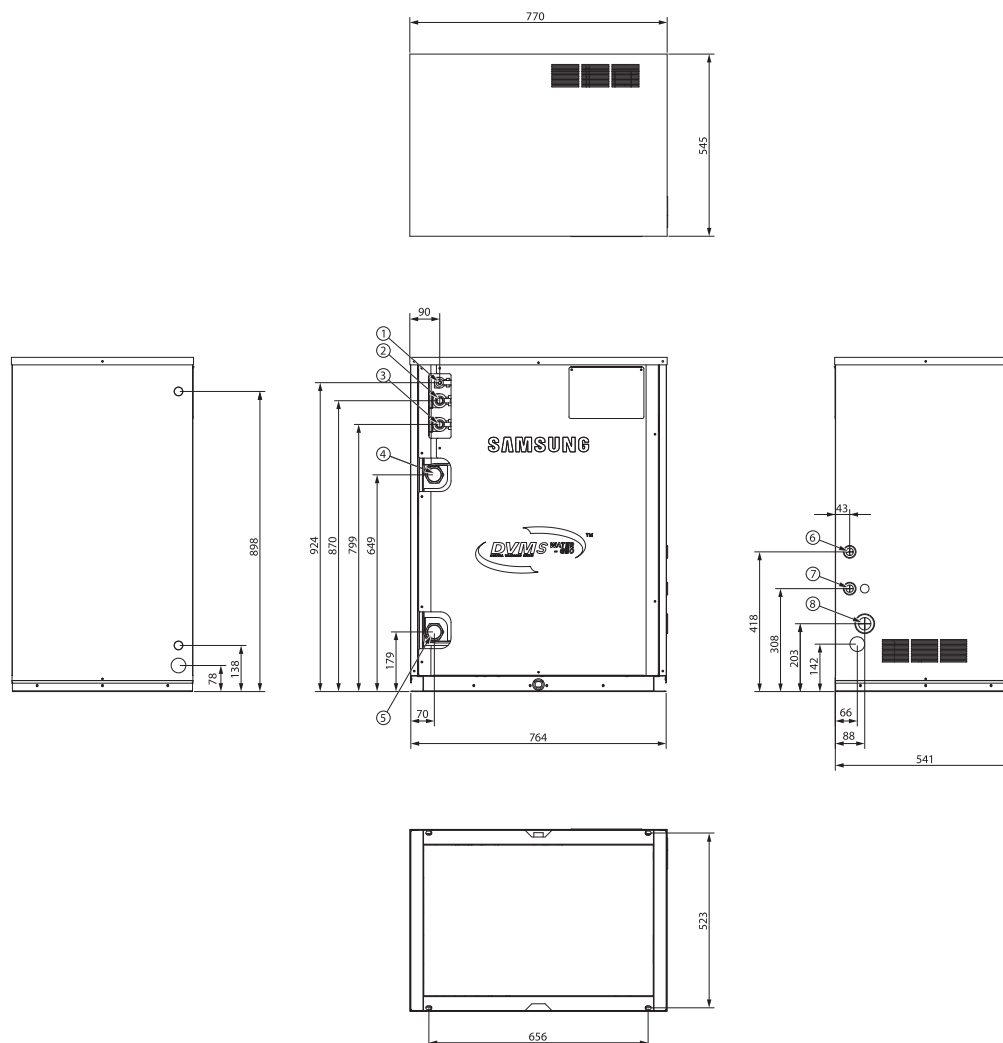

NO	Name	Description
1	Liquid Ref. pipe	Ø19.05 (3/4)
2	High Pressure Gas Ref. pipe	Ø28.58 (1 1/8)
3	Low Pressure Gas Ref. pipe	Ø 34.92 (1 3/8)
4	Water outlet pipe	PT 2
5	Water inlet pipe	PT 2
6	Communication wiring conduits	
7	External contact wiring	
8	Power wiring conduits	

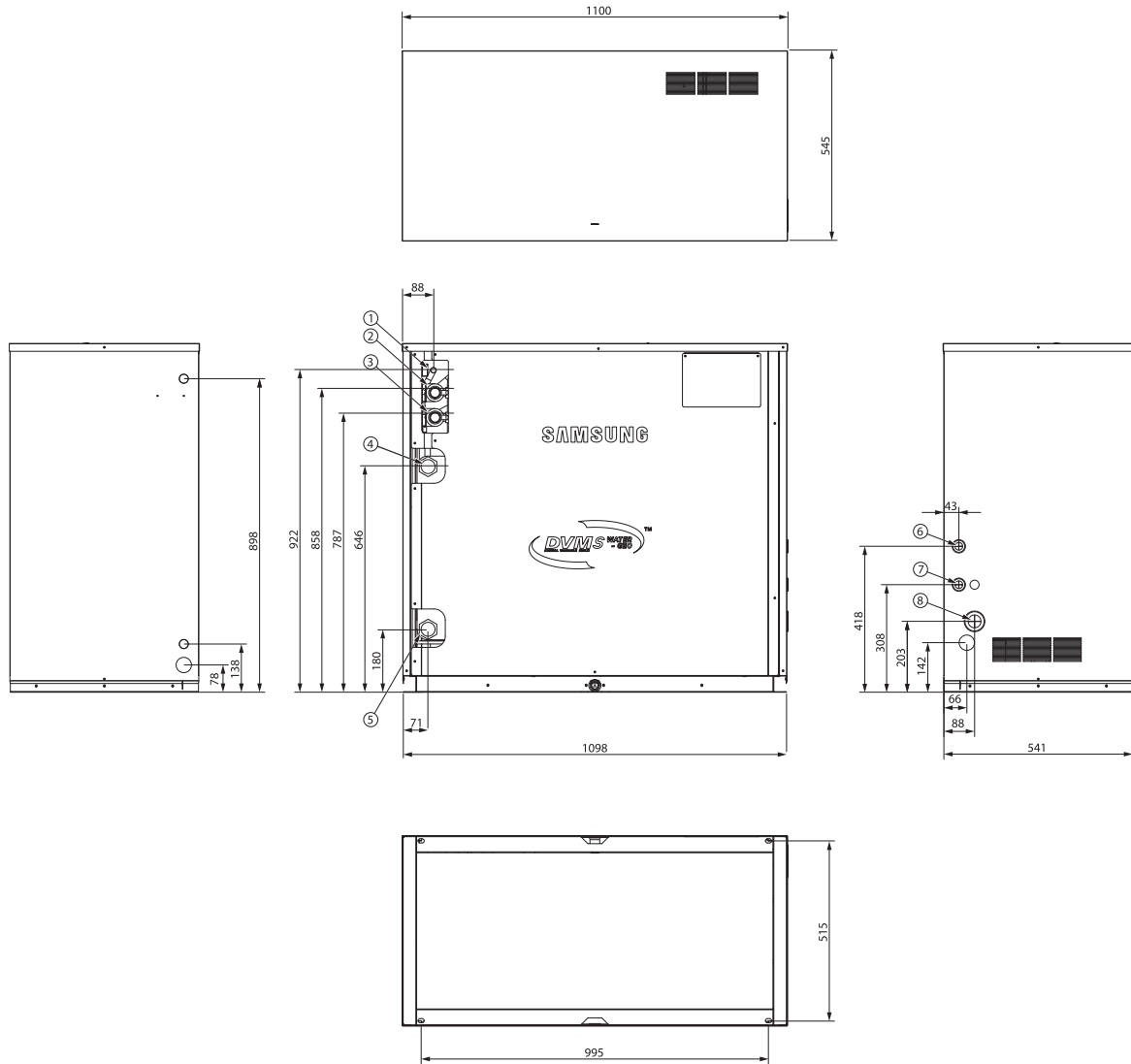

NO	Name	Description
1	Liquid Ref. pipe	15.88 (5/8)
2	High Pressure Gas Ref. pipe	Ø28.58 (1 1/8)
3	Low Pressure Gas Ref. pipe	Ø28.58 (1 1/8)
4	Water outlet pipe	PT1 1/4
5	Water inlet pipe	PT1 1/4
6	Communication wiring conduits	
7	External contact wiring	
8	Power wiring conduits	

Dimensional drawings ^{2/2}

DVM S Water (R410A)

AM300MXWANR/EU

Units: mm [inches]

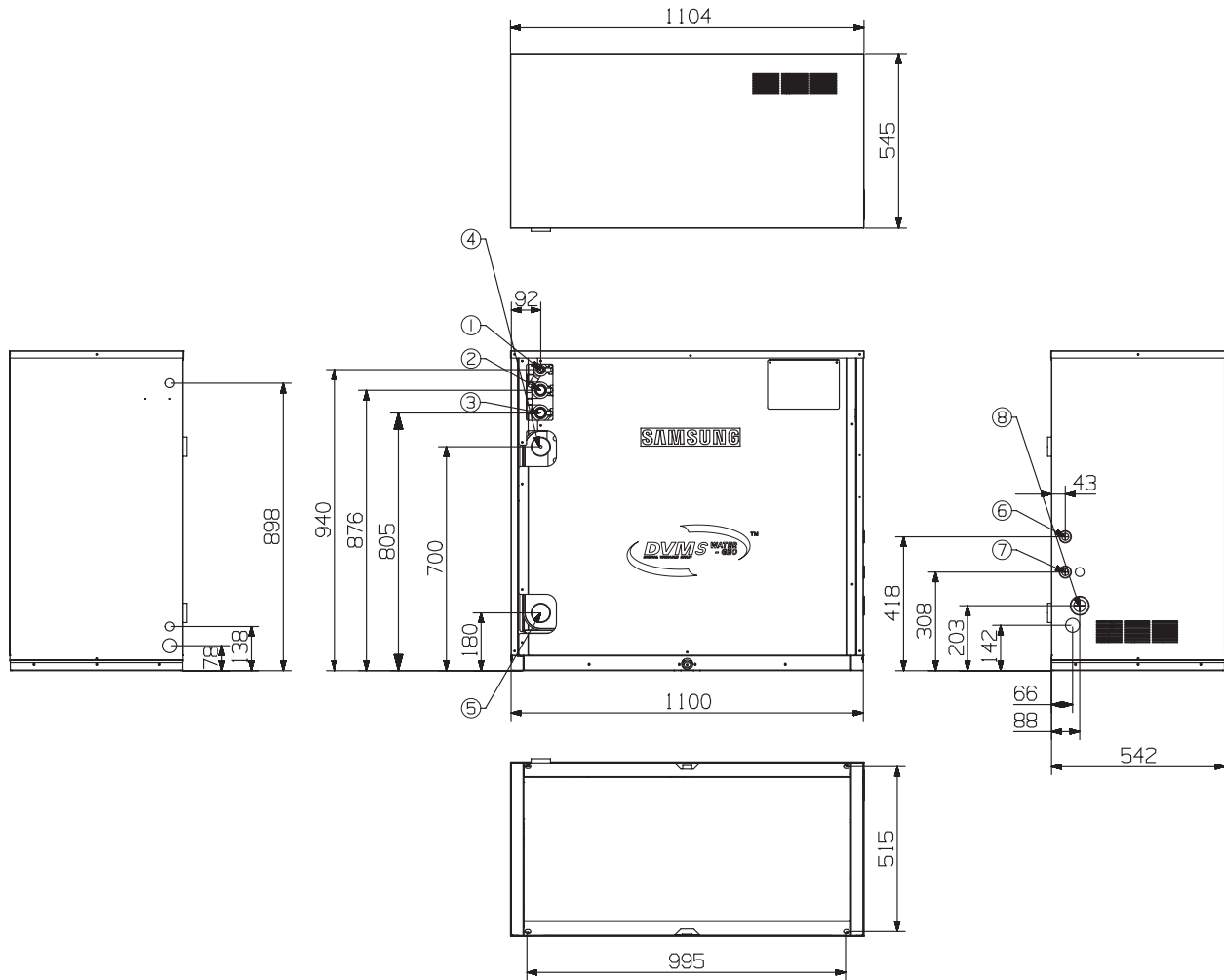

NO	Name	Description
1	Liquid Ref. pipe	Ø19.05 (3/4)
2	High Pressure Gas Ref. pipe	Ø28.58 (1 1/8)
3	Low Pressure Gas Ref. pipe	Ø34.92 (1 3/8)
4	Water outlet pipe	PT 2
5	Water inlet pipe	PT 2
6	Communication wiring conduits	
7	External contact wiring	
8	Power wiring conduits	



Dimensional drawings

Universal 360 Cassette (square)

AM045DN6DKG/EU, AM056DN6DKG/EU, AM071DN6DKG/EU, AM090DN6DKG/EU

Units: mm [inches]

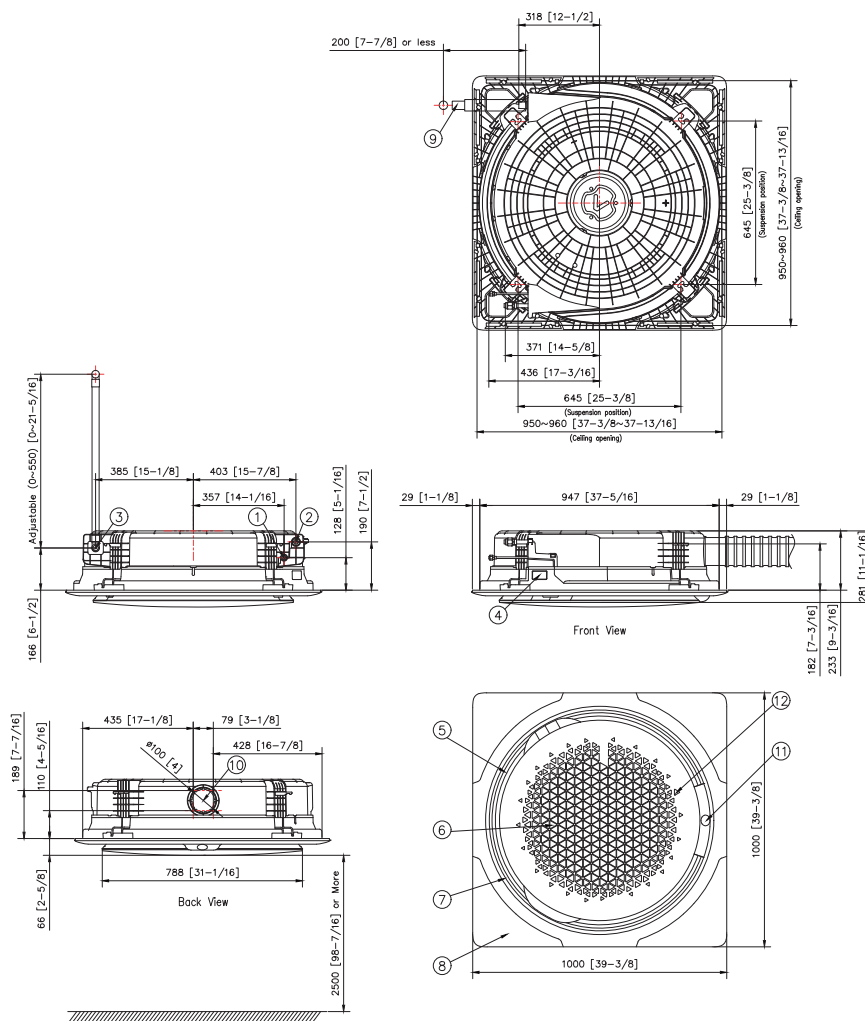

NO	Name	Description	
		AM045DN6DKG/EU AM056DN6DKG/EU	AM071DN6DKG/EU AM090DN6DKG/EU
1	Gas pipe connection	Ø12.70 (1/2")	Ø15.88 (5/8")
2	Liquid pipe connection	Ø6.35 (1/4")	Ø9.52 (3/8")
3	Drain pipe connection	VP25 (OD32, ID25)	
4	Power supply/Communication wiring conduit	-	
5	Air Discharge opening	-	
6	Air suction grille	-	
7	Suction rim for Booster fan	-	
8	Decoration cover	-	
9	Drain hose (Accessory)	-	
10	Fresh air intake knockout hole	Use M4 Screw	
11	Display Window	-	
12	Remote controller receiver	-	

- As for suspension bolt, please use M8 - M10. (Procured at local site)
- Make sure the spacing between the ceiling and the cassette is no more than 29 mm [1-1/4]. Max ceiling opening : 960 mm [36-13/16].
- When the condition exceed 30°C and RH 80% in the ceiling or fresh air is inducted into the ceiling, and additional insulation is required (polyethylene foam , thickness 10 mm [3/8] or more)

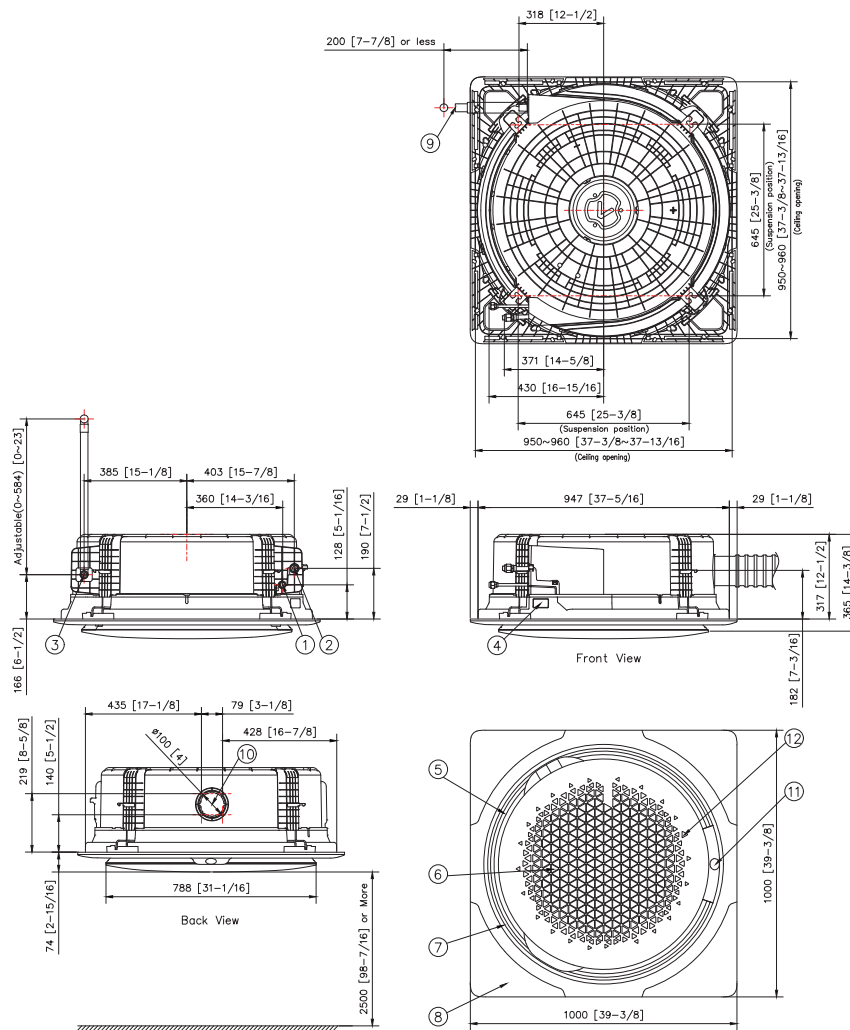

NO	Name	Description
1	Gas pipe connection	Ø15.88 (5/8")
2	Liquid pipe connection	Ø9.52 (3/8")
3	Drain pipe connection	VP25 (OD32, ID25)
4	Power supply/Communication wiring conduit	-
5	Air Discharge opening	-
6	Air suction grille	-
7	Suction rim for Booster fan	-
8	Decoration cover	-
9	Drain hose (Accessory)	-
10	Fresh air intake knockout hole	Use M4 Screw
11	Display Window	-
12	Remote controller receiver	-

- As for suspension bolt, please use M8 - M10. (Procured at local site)
- Make sure the spacing between the ceiling and the cassette is no more than 29 mm [1-1/4]. Max ceiling opening : 960 mm [36-13/16].
- When the condition exceed 30°C and RH 80% in the ceiling or fresh air is inducted into the ceiling, and additional insulation is required (polyethylene foam , thickness 10 mm [3/8] or more)

Dimensional drawings

Universal 360 Cassette (circular)

AM045DN6DKG/EU, AM056DN6DKG/EU, AM071DN6DKG/EU, AM090DN6DKG/EU

Units: mm [inches]

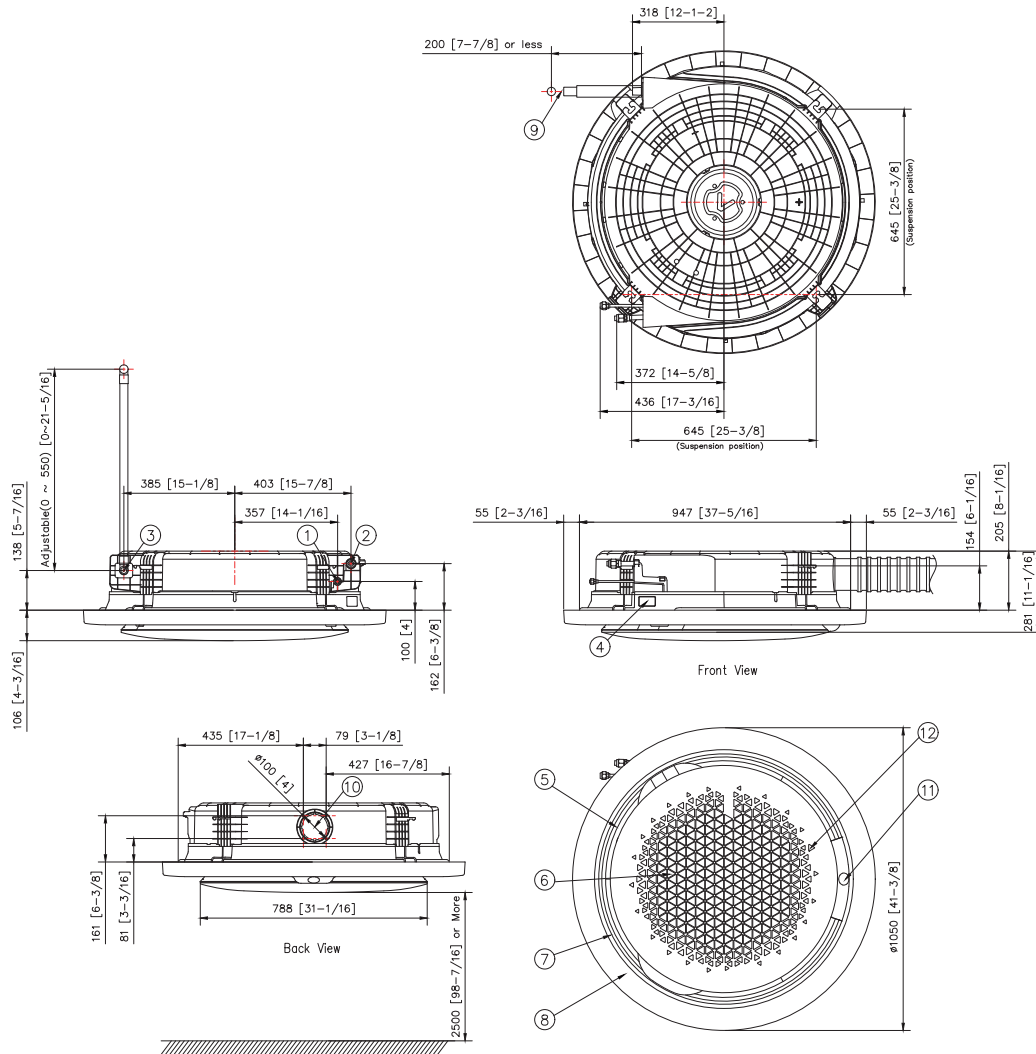

NO	Name	Description	
		AM045DN6DKG/EU AM056DN6DKG/EU	AM071DN6DKG/EU AM090DN6DKG/EU
1	Liquid pipe connection	Ø6.35[1/4]	Ø9.52[3/8]
2	Gas pipe connection	Ø12.7[1/2]	Ø15.88[5/8]
3	Drain pipe connection	VP25 (OD32, ID25)	
4	Power supply/communication wiring conduit	-	
5	Air discharge opening	-	
6	Air suction grille	-	
7	Suction rim for booster fan	-	
8	Decoration cover	-	
9	Drain hose (Accessory)	-	
10	Fresh air intake knock-out hole	Use M4 Screw	
11	Display window	-	
12	Remote controller receiver	-	

- As for suspension bolt, please use M8 – M10. (Procured at local site)
- Make sure the spacing between the ceiling and the cassette is no more than 10 mm[3/8]
- When the condition exceed 30°C and RH 80% in the ceiling or fresh air is inducted into the ceiling, and additional insulation is required (polyethylene foam, thickness 10 mm[3/8] or more)
- When installing the circular panel on the ceiling, make sure to install 2 or more inspection holes for the maintenance.
- The circular panel is by default available in exposed installation. Make inspection holes on the ceiling for easier installation and maintenance, as shown in the following table. (The size of an inspection hole must be at least 450 mm x 450 mm.)

Category	Inspection hole		
	Recessed installation	Exposed installation	
	Integrated	Suspended	
Square panel	1 ea	-	
Circular panel	2 ea	-	

- A suspended ceiling structure can substitute for the inspection holes.

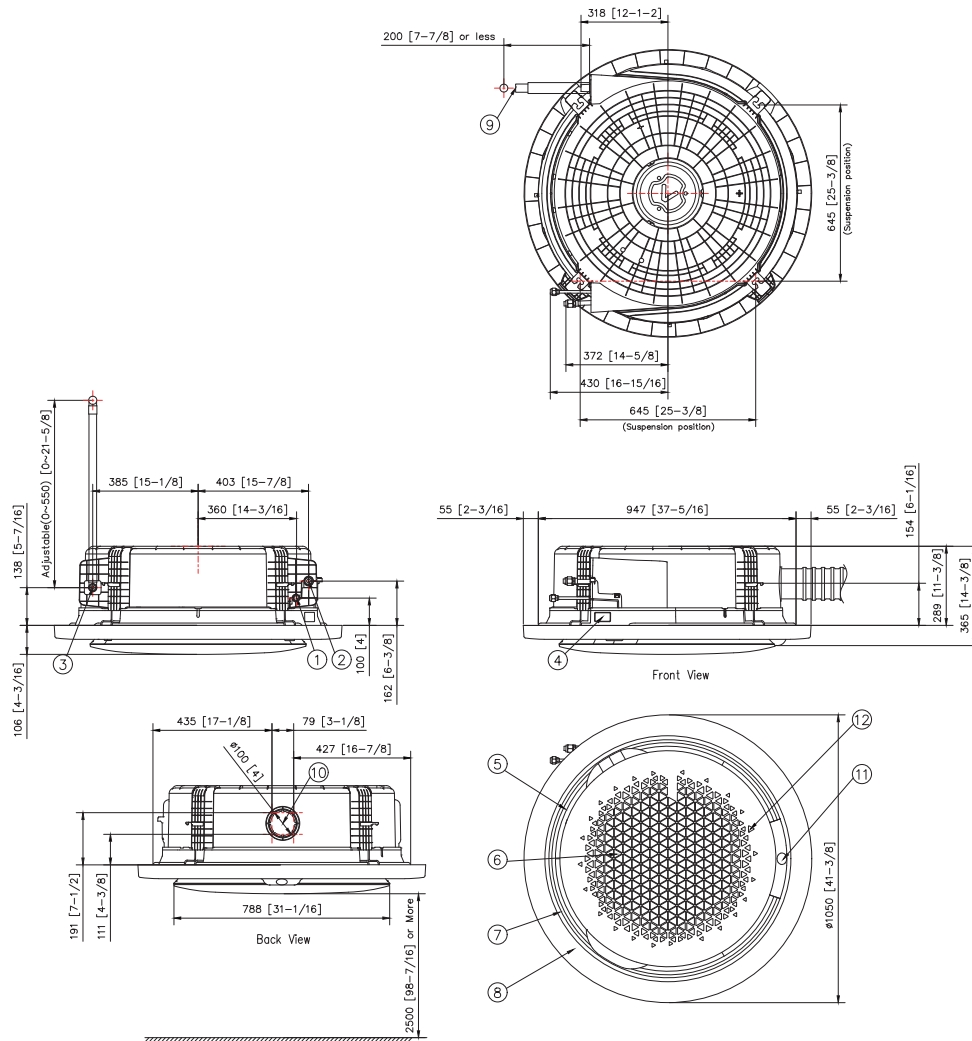

NO	Name	Description
1	Liquid pipe connection	Ø9.52[3/8]
2	Gas pipe connection	Ø15.88[5/8]
3	Drain pipe connection	VP25 (OD32, ID25)
4	Power supply/communication wiring conduit	-
5	Air discharge opening	-
6	Air suction grille	-
7	Suction rim for booster fan	-
8	Decoration cover	-
9	Drain hose (Accessory)	-
10	Fresh air intake knock-out hole	Use M4 Screw
11	Display window	-
12	Remote controller receiver	-

- As for suspension bolt, please use M8 ~ M10. (Procured at local site)
- Make sure the spacing between the ceiling and the cassette is no more than 10mm[3/8]
- When the condition exceed 30°C and RH 80% in the ceiling or fresh air is induced into the ceiling, and additional insulation is required (polyethylene foam, thickness 10mm[3/8] or more)
- When installing the circular panel on the ceiling, make sure to install 2 or more inspection holes for the maintenance.
- The circular panel is by default available in exposed installation. Make inspection holes on the ceiling for easier installation and maintenance, as shown in the following table. (The size of an inspection hole must be at least 450 mm x 450 mm.)

Category	Inspection hole		
	Recessed installation		Exposed installation
	Integrated	Suspended	
Square panel	1 ea	-	
Circular panel	2 ea		

- A suspended ceiling structure can substitute for the inspection holes.

Dimensional drawing

Universal WindFree™ 4-Way 600 x 600 Cassette

AM0**DNNDKG/EU

Units: mm [inches]

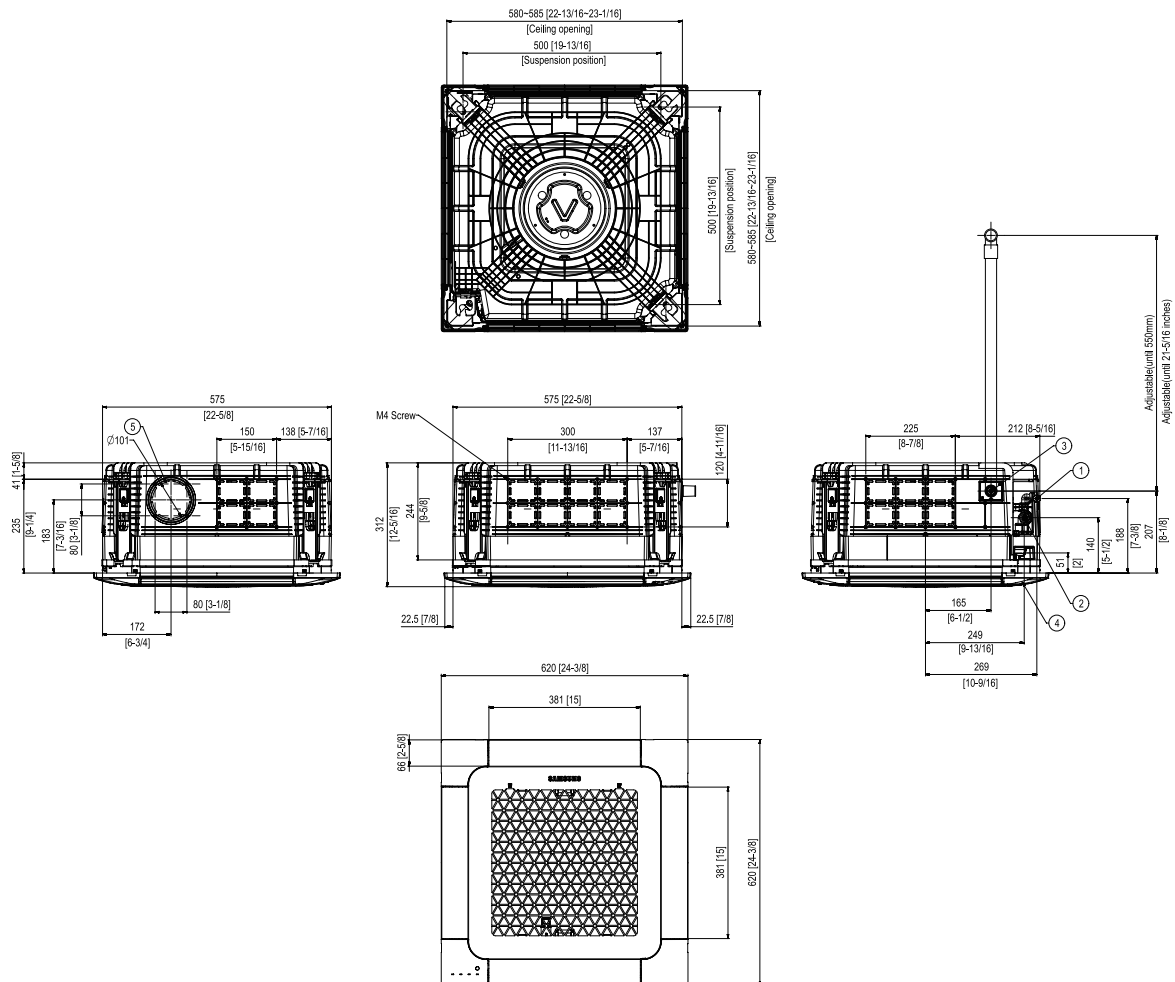

NO	Name	Description
1	Liquid pipe connection	Ø6.35 (1/4)
2	Gas pipe connection	Ø12.70 (1/2)
3	Drain pipe connection	VP25 (OD 32, ID 25)
4	Power supply/communication wiring conduits	Use M4 Screw
5	Fresh air intake knock-out hole	Ø10 [4], use M4 Screw

Note: As for suspension bolt, please use M8-M10. (Procured at local site)



Dimensional drawings ^{1/2}

Universal WindFree™ 4-Way Cassette

AM028DN4DKG/EU, AM036DN4DKG/EU, AM045DN4DKG/EU, AM056DN4DKG/EU, AM071DN4DKG/EU

Units: mm [inches]

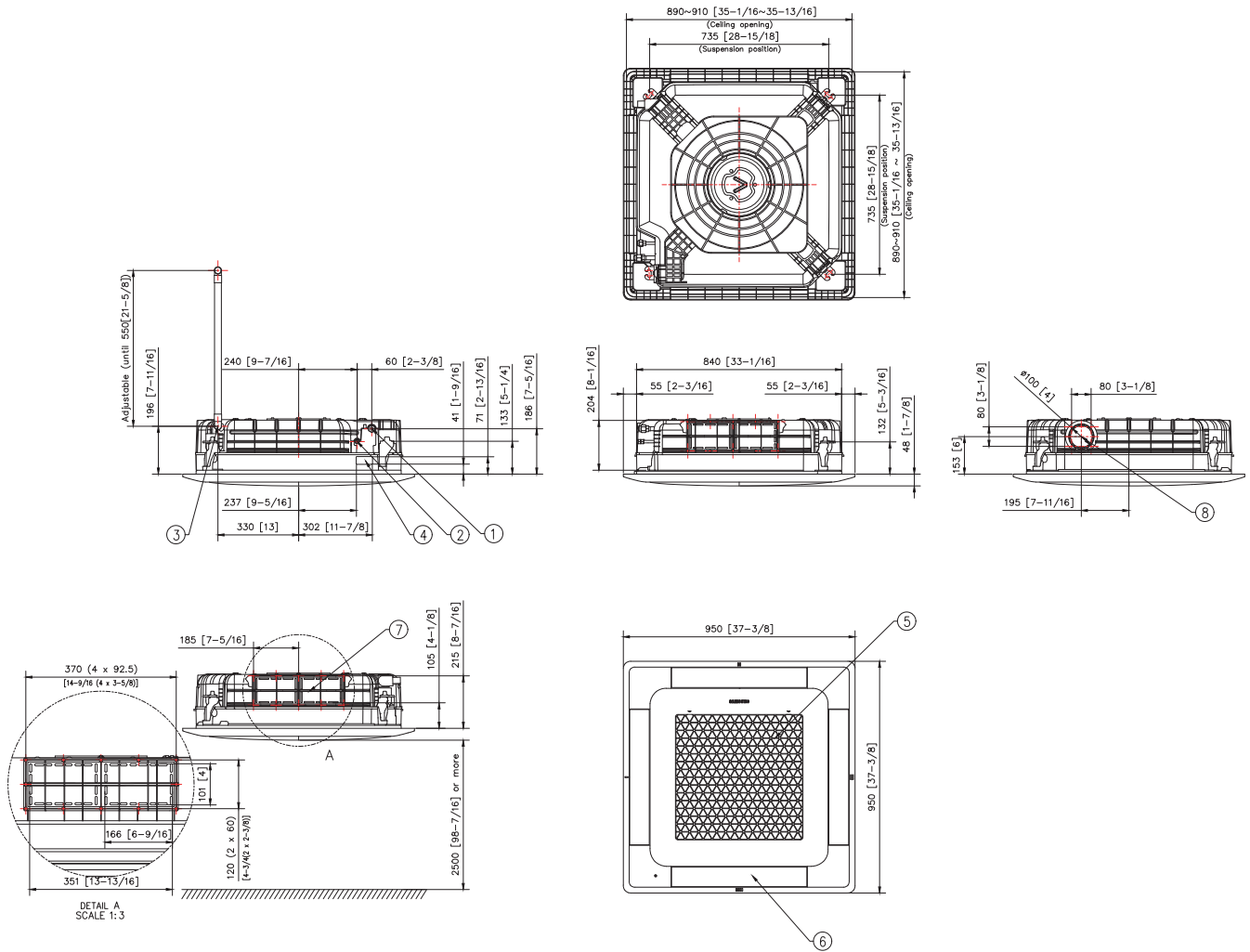

NO	Name	Description
		AM028DN4DKG/EU, AM036DN4DKG/EU, AM045DN4DKG/EU, AM056DN4DKG/EU
		AM071DN4DKG/EU
1	Gas pipe connection	Ø12.7 (1/2)
2	Liquid pipe connection	Ø6.35[1/4]
3	Drain pipe connection	VP25 (OD 32, ID 25)
4	Power supply/communication wiring conduits	
5	Air Inlet Grille	
6	Air Outlet Louver	
7	Sub - duct	* The sub duct is not applicable to the WindFree™ panel
8	Fresh air intake	Ø10 [4], use M4 Screw

Note: As for suspension bolt, please use M8-M10. (Procured at local site)

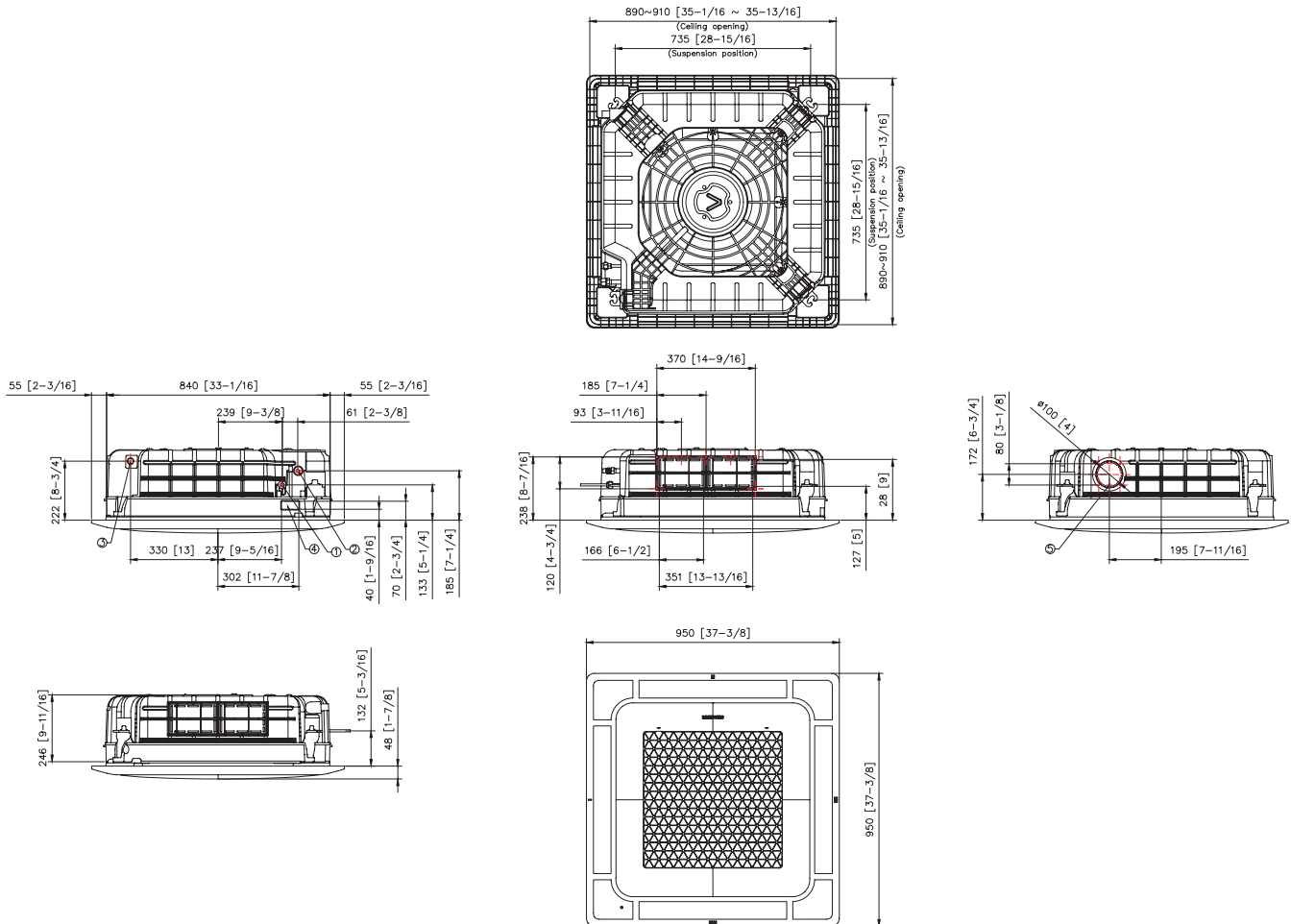

NO	Name	Description
		AM022DN4FKG/EU, AM028DN4FKG/EU AM036DN4FKG/EU, AM045DN4FKG/EU
		AM090DN4DKG/EU, AM112DN4DKG/EU
1	Liquid pipe connection	Ø6.35 (1/4) Ø9.52 (3/8)
2	Gas pipe connection	Ø12.7 (1/2) Ø15.88 (5/8)
3	Drain pipe connection	VP25 (OD 32, ID 25)
4	Power supply/communication wiring conduits	
5	Fresh air intake knock-out hole	Ø10 [4], use M4 Screw

Note: As for suspension bolt, please use M8-M10. (Procured at local site)

Dimensional drawings ^{2/2}

Universal WindFree™ 4-Way Cassette

AM128DN4DKG/EU, AM140DN4DKG/EU, AM056DN4FKG/EU, AM071DN4FKG/EU

Units: mm [inches]

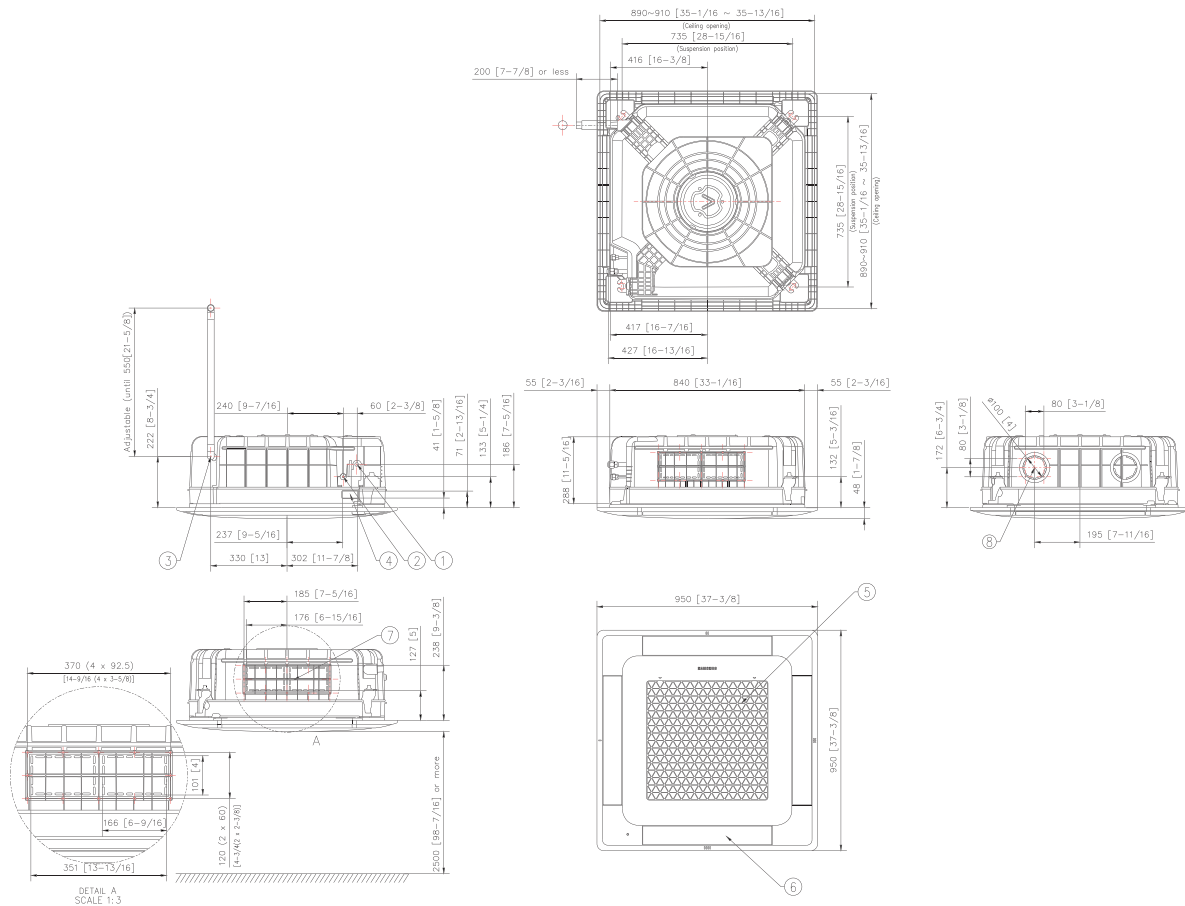

NO	Name	Description	
		AM056DN4FKG/EU	AM071DN4FKG/EU, AM128DN4DKG/EU, AM140DN4DKG/EU
1	Gas pipe connection	Ø6.35[1/4]	Ø15.88 (5/8)
2	Liquid pipe connection	Ø12.7[1/2]	Ø9.52[3/8]
3	Drain pipe connection		VP25 (OD 32, ID 25)
4	Power supply/communication wiring conduits		
5	Air Inlet Grille		
6	Air Outlet Louver		
7	Sub - duct	* The sub duct is not applicabel to the WindFree™ panel	
8	Fresh air intake		Ø10 [4], use M4 Screw

Note: As for suspension bolt, please use M8-M10. (Procured at local site)



Dimensional drawings ^{1/2}

Universal WindFree™ 1-Way Cassette

AM017DN1DKG/EU, AM022DN1DKG/EU

Units: mm [inches]

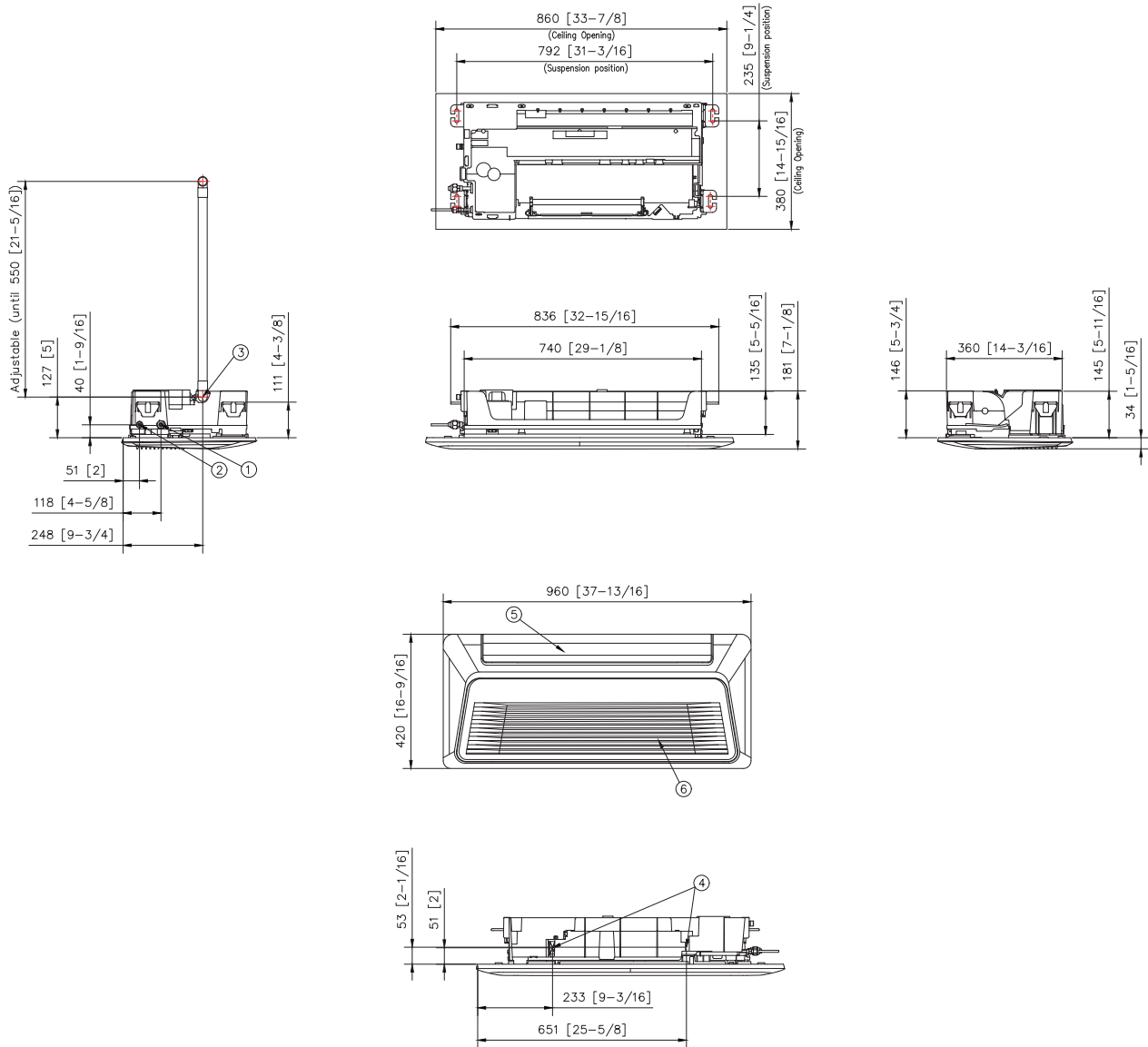

NO	Name	Description
1	Gas pipe connection	Ø12.7 (1/2")
2	Liquid pipe connection	Ø6.35 (1/4")
3	Drain pipe connection	VP25(OD32, ID25)
4	Power supply/Communication wiring conduit	-
5	Air outlet louver	-
6	Air inlet grille	-

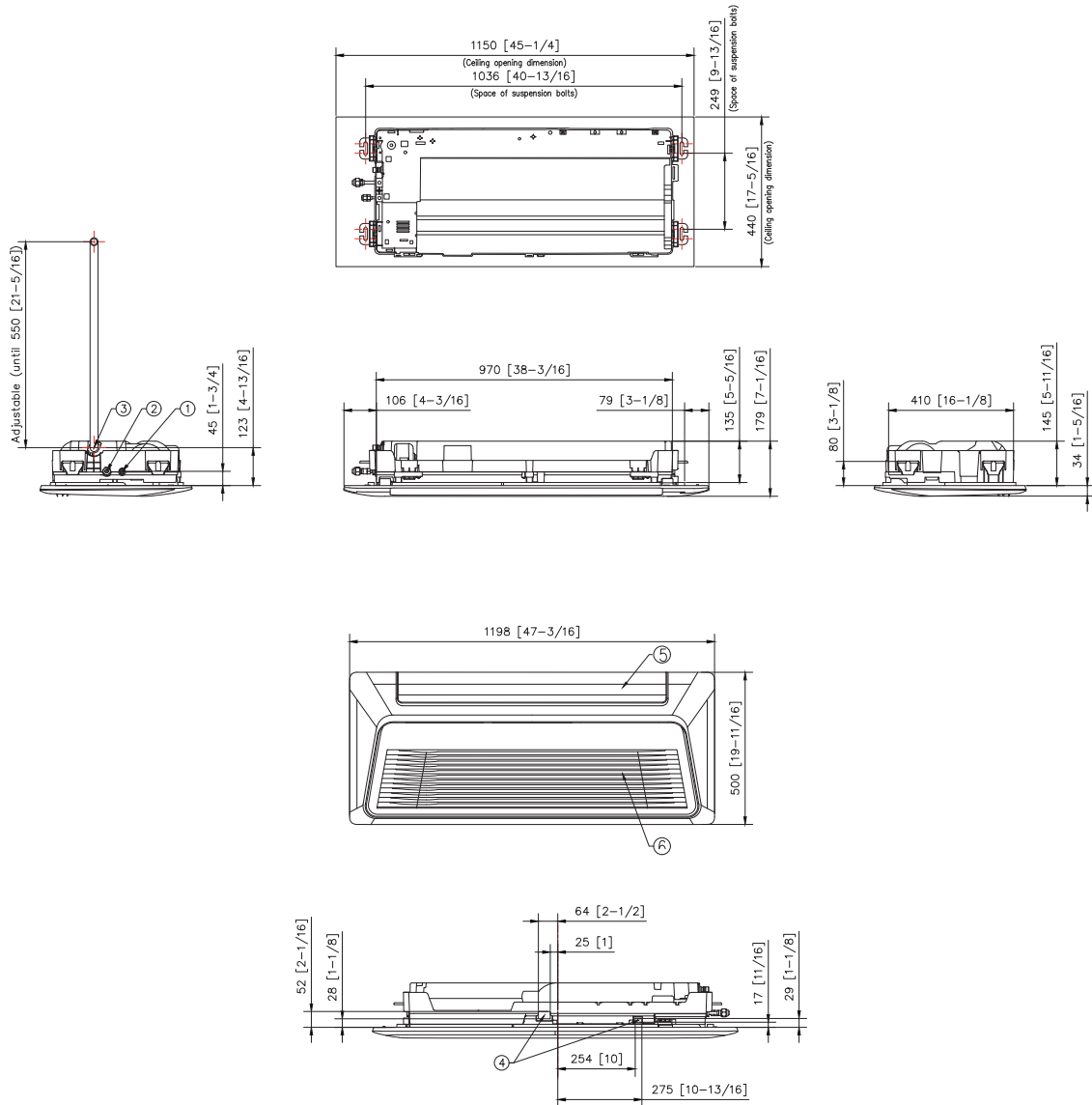

NO	Name	Description
1	Gas pipe connection	Ø12.7 (1/2")
2	Liquid pipe connection	Ø6.35 (1/4")
3	Drain pipe connection	VP25(OD32, ID25)
4	Power supply/Communication wiring conduit	-
5	Air outlet louver	-
6	Air inlet grille	-

Dimensional drawings ^{2/2}

Universal WindFree™ 1-Way Cassette

AM056DN1DKG/EU, AM071DN1DKG/EU

Units: mm [inches]

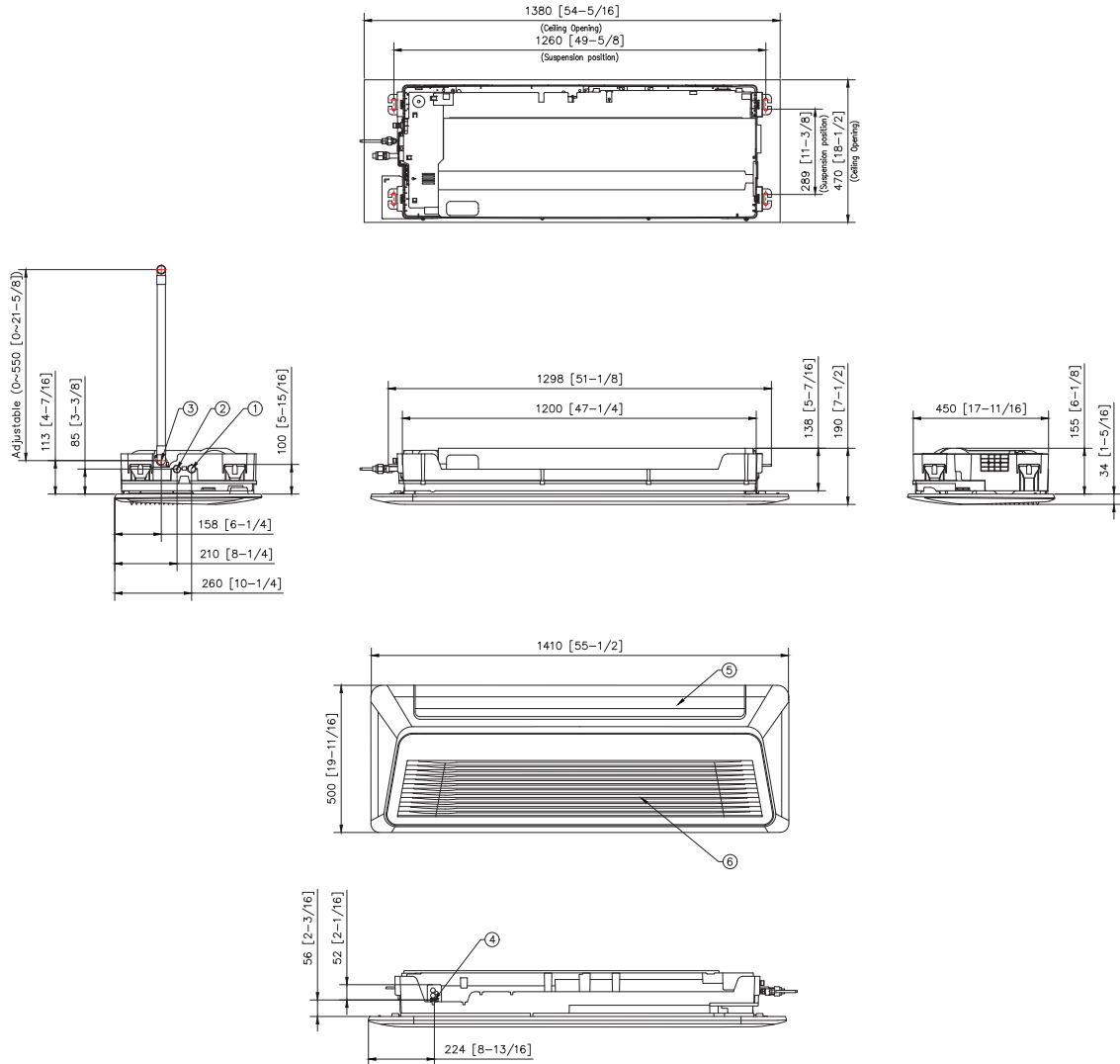

NO	Name	Description	
		5.2 kW	7.1 kW
1	Gas pipe connection	Ø12.70 (1/2")	Ø15.88 (5/8")
2	Liquid pipe connection	Ø6.35 (1/4")	Ø9.52 (3/8")
3	Drain pipe connection	VP25 (OD32, ID25)	
4	Power supply/Communication wiring conduit	-	
5	Air outlet louver	-	
6	Air inlet grille	-	







Dimensional drawings ^{1/2}

Universal LSP Duct (drain pump included)

AM017DNLKDG/EU, AM022DNLKDG/EU, AM028DNLKDG/EU, AM036DNLKDG/EU

Units: mm [inches]

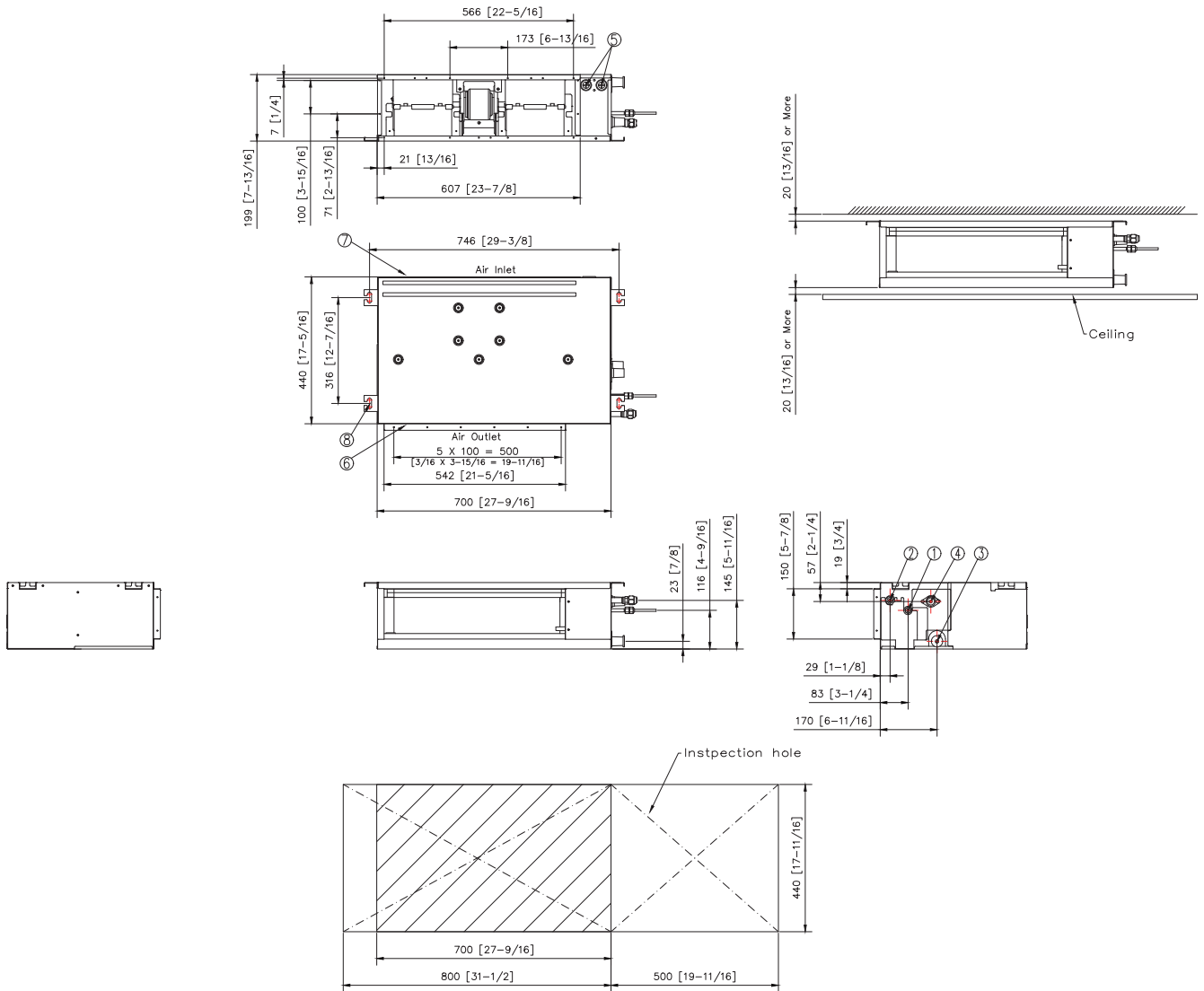

NO	Name	Description
1	Liquid pipe connection	Ø6.35 (1/4)
2	Gas pipe connection	Ø12.70 (1/2)
3	Drain pipe connection without drain pump	VP25 (OD 32, ID 25)
4	Drain pipe connection with drain pump	
5	Power supply/communication wiring conduits	
6	Air discharge grille flange	
7	Return air side	
8	Hook	Ø9.52 or M10

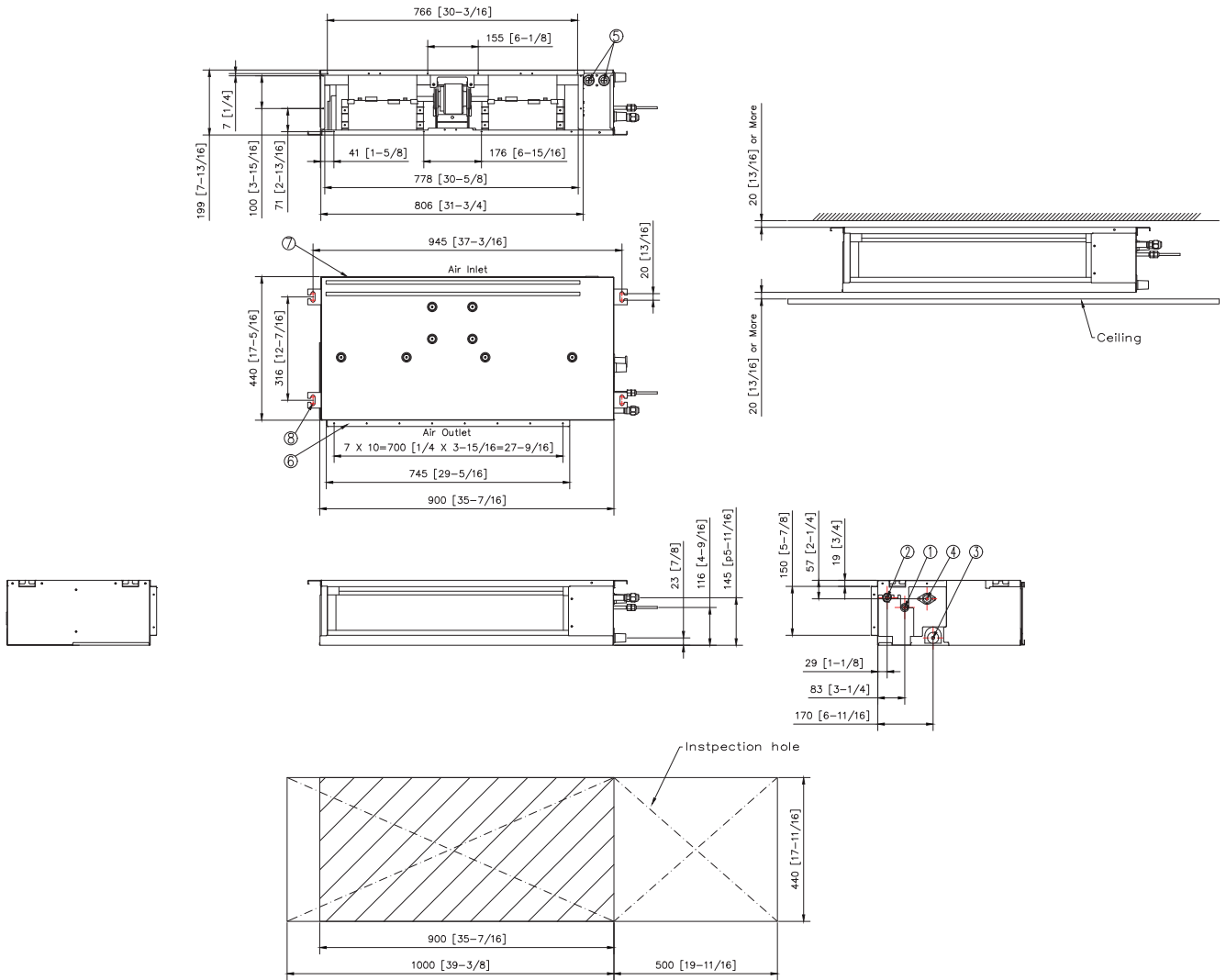

NO	Name	Description
1	Liquid pipe connection	Ø6.35 (1/4)
2	Gas pipe connection	Ø12.70 (1/2)
3	Drain pipe connection without drain pump	VP25 (OD 32, ID 25)
4	Drain pipe connection with drain pump	
5	Power supply/communication wiring conduits	
6	Air discharge grille flange	
7	Return air side	
8	Hook	Ø9.52 or M10

Dimensional drawings ^{2/2}

Universal LSP Duct (drain pump included)

AM071DNLDKG/EU

Units: mm [inches]

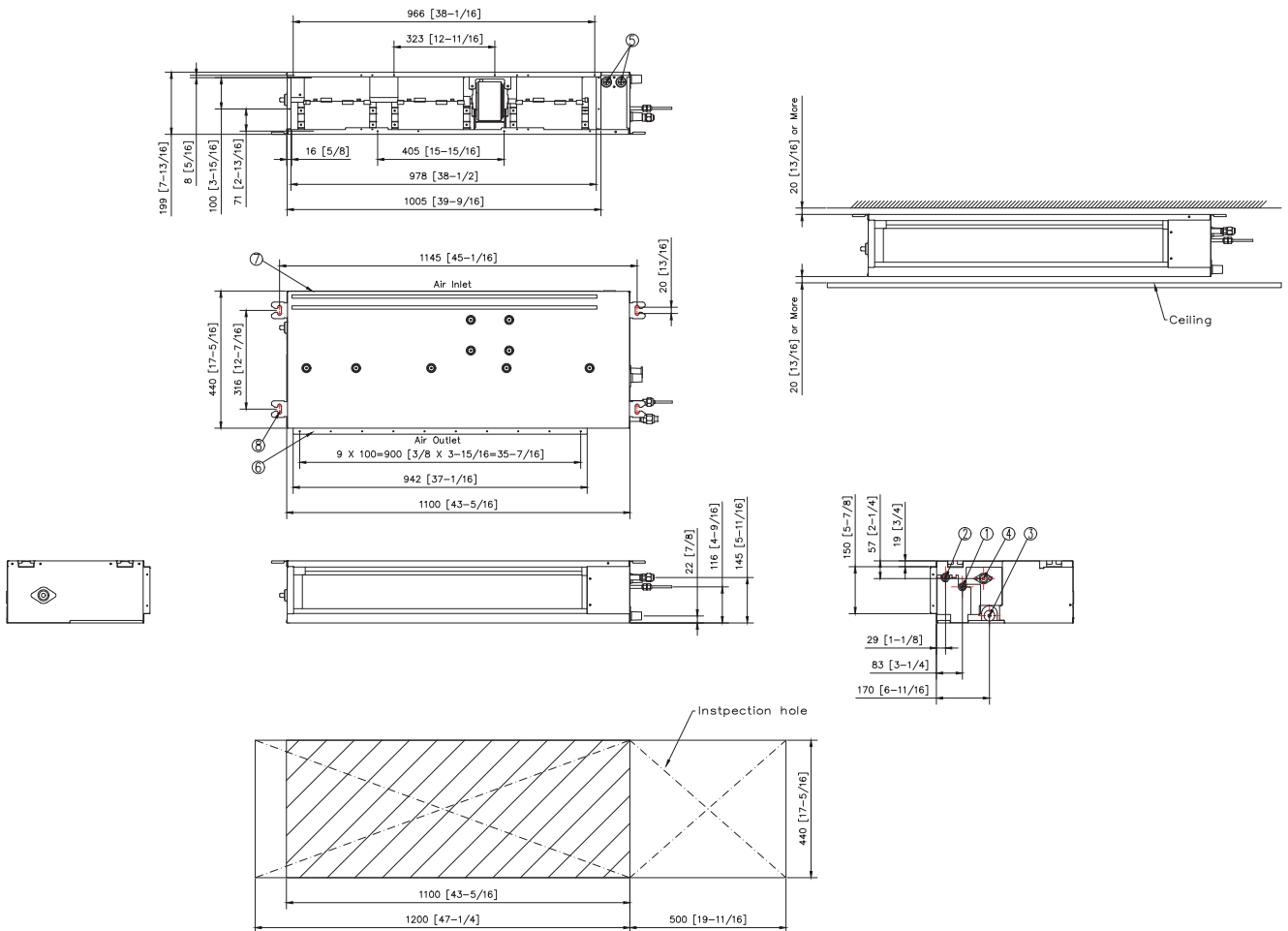

NO	Name	Description
1	Liquid pipe connection	Ø9.52 (3/8)
2	Gas pipe connection	Ø15.88 (5/8)
3	Drain pipe connection without drain pump	VP25 (OD 32, ID 25)
4	Drain pipe connection with drain pump	
5	Power supply/communication wiring conduits	
6	Air discharge grille flange	
7	Return air side	
8	Hook	Ø9.52 or M10



Dimensional drawings ^{1/2}

LSP Duct (drain pump excluded, R410A)

AM017/022/028/036ANLDKH/EU

Units: mm [inches]

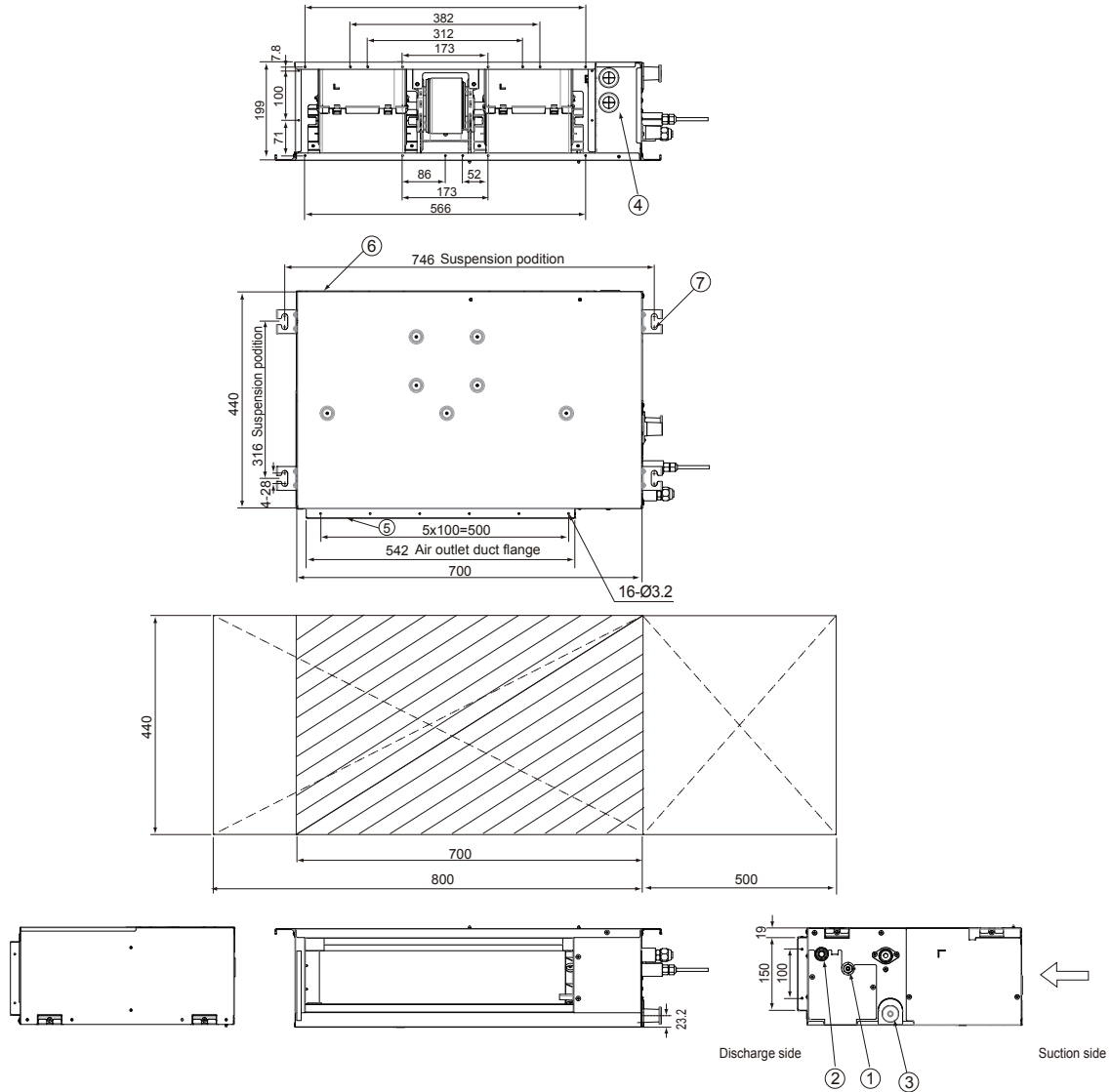

NO	Name	Description
1	Refrigerant Liquid Pipe	Ø6.35 [1/4"]
2	Refrigerant Gas Pipe	Ø12.70 [1/2"]
3	Drain pipe connection without drain pump	VP25 (OD 32, ID 25)
4	Power supply / Communication connection	-
5	Air discharge grille flange	-
6	Return air side	-
7	Hook	Ø9.52 or M10

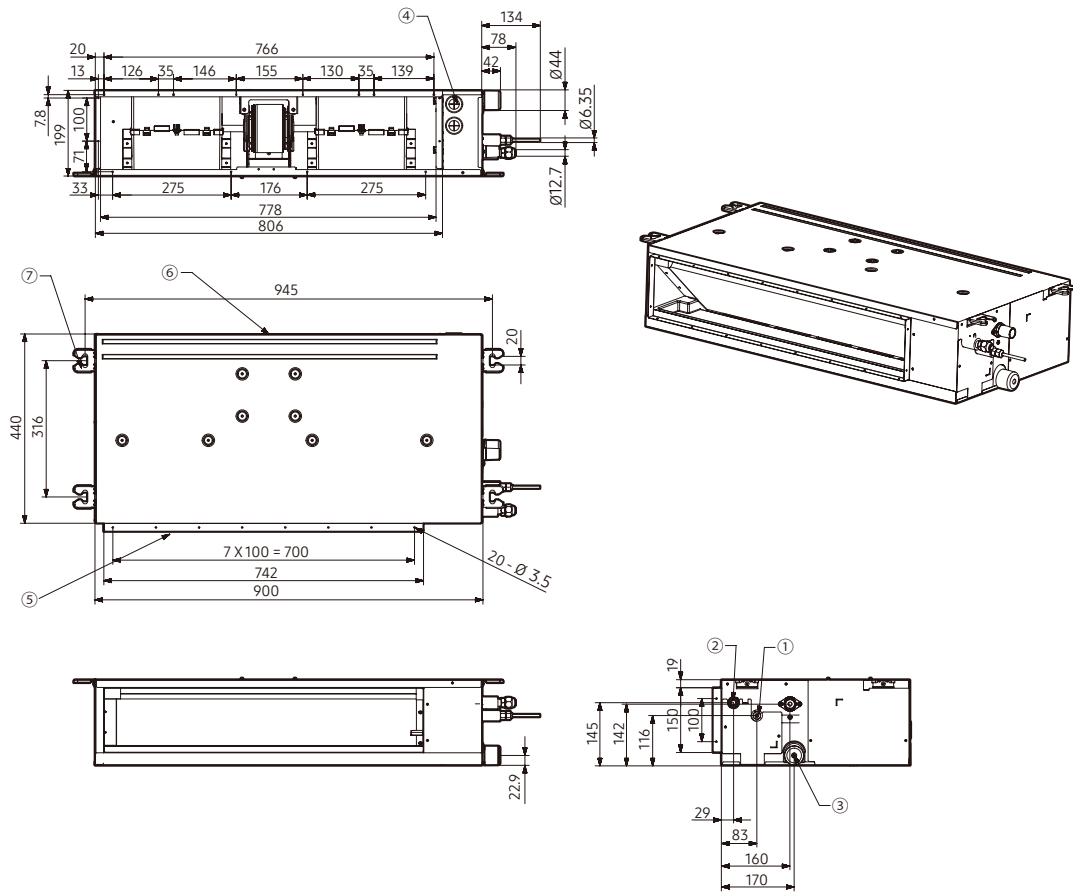

NO	Name	Description
1	Refrigerant Liquid Pipe	Ø6.35 [1/4"] Flare Connection
2	Refrigerant Gas Pipe	Ø12.70 [1/2"] Flare Connection
3	Condensate Drain (Option)	VP25 (OD 32, ID 25)
4	Power & Comm. Wiring Conduits	-
5	Supply Air Flange	-
6	Return Air Flange	-
7	Hook	-

Dimensional drawings ^{2/2}

LSP Duct (drain pump excluded, R410A)

AM071ANLDKH/EU

Units: mm [inches]

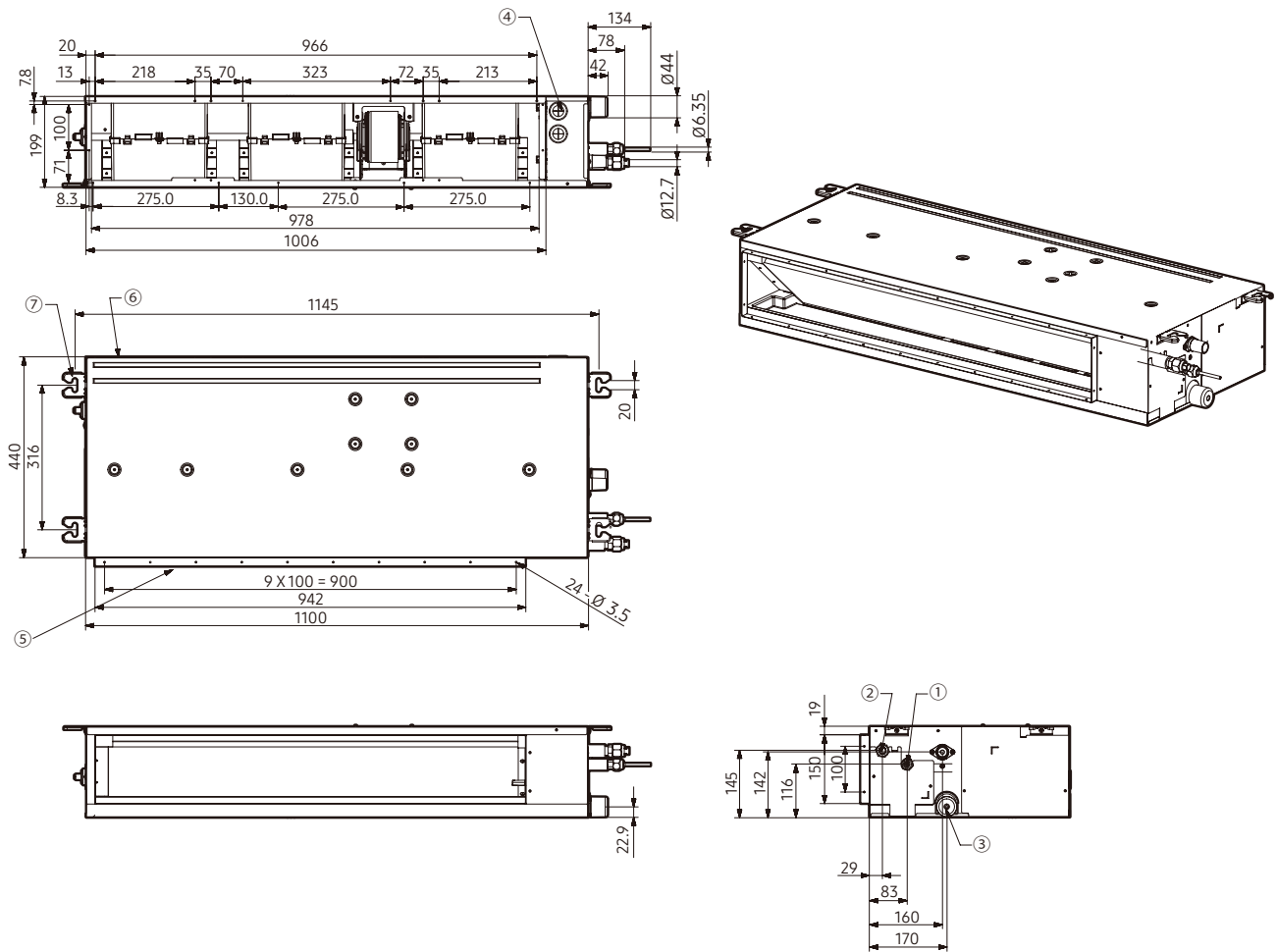

NO	Name	Description
1	Refrigerant Liquid Pipe	Ø9.52 [3/8"] Flare Connection
2	Refrigerant Gas Pipe	Ø15.88 [5/8"] Flare Connection
3	Condensate Drain (Option)	VP25 (OD 32, ID 25)
4	Power & Comm. Wiring Conduits	-
5	Supply Air Flange	-
6	Return Air Flange	-
7	Hook	-

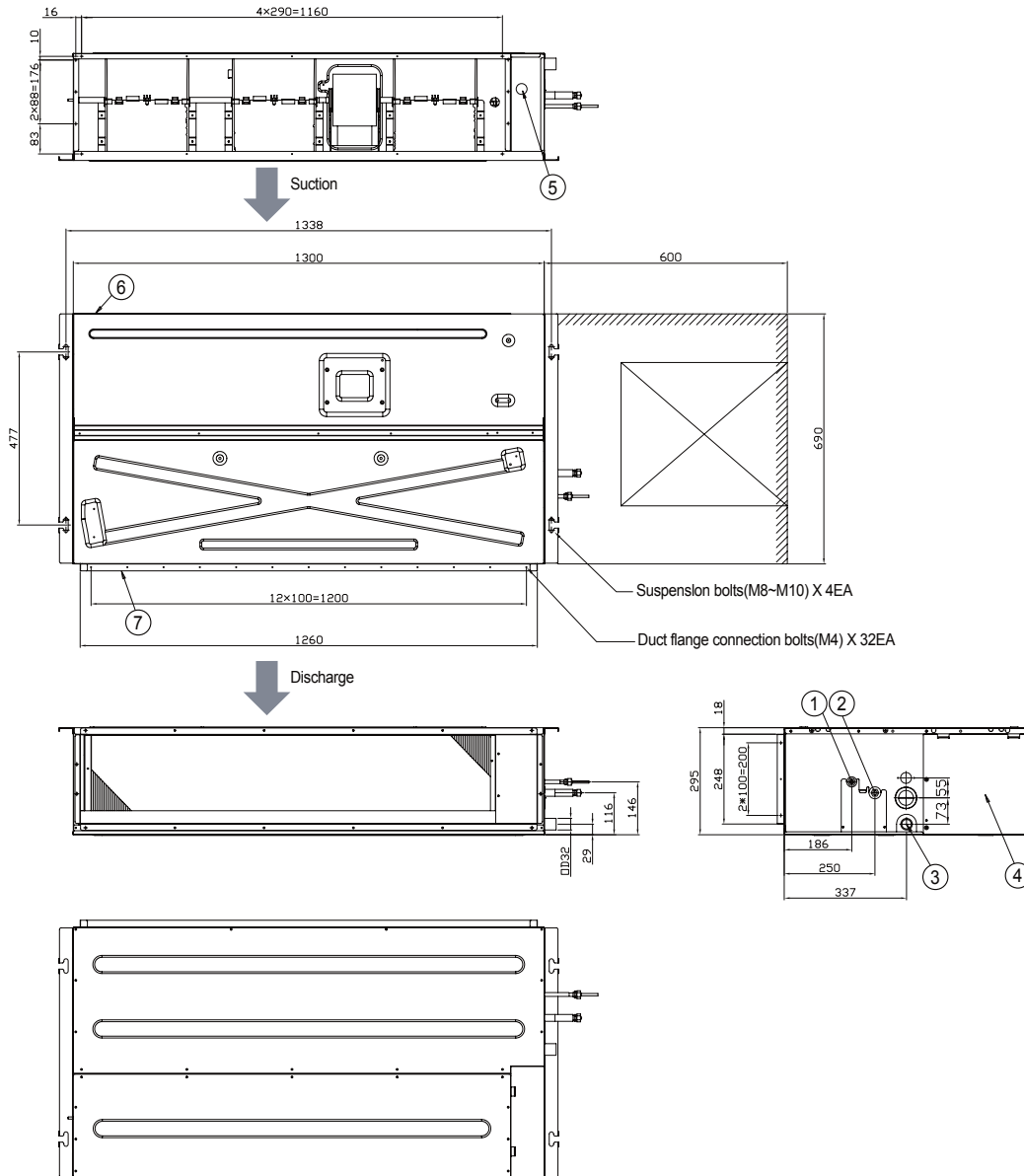

NO	Name	Description
1	Refrigerant Liquid Pipe	Ø9.52 [3/8"] Flare Connection
2	Refrigerant Gas Pipe	Ø15.88 [5/8"] Flare Connection
3	Drain pipe connection without drain pump	VP25 (OD 32, ID 25)
4	Control unit	-
5	Conduit for power supply & communication wiring	-
6	Return air side	-
7	Air outlet duct flange	-

Dimensional drawings ^{1/2}

Universal MSP Duct (drain pump included)

AM022DNMDKG/EU, AM028DNMDKG/EU, AM036DNMDKG/EU, AM045DNMDKG/EU, AM056DNMDKG/EU, AM071DNMDKG/EU

Units: mm [inches]

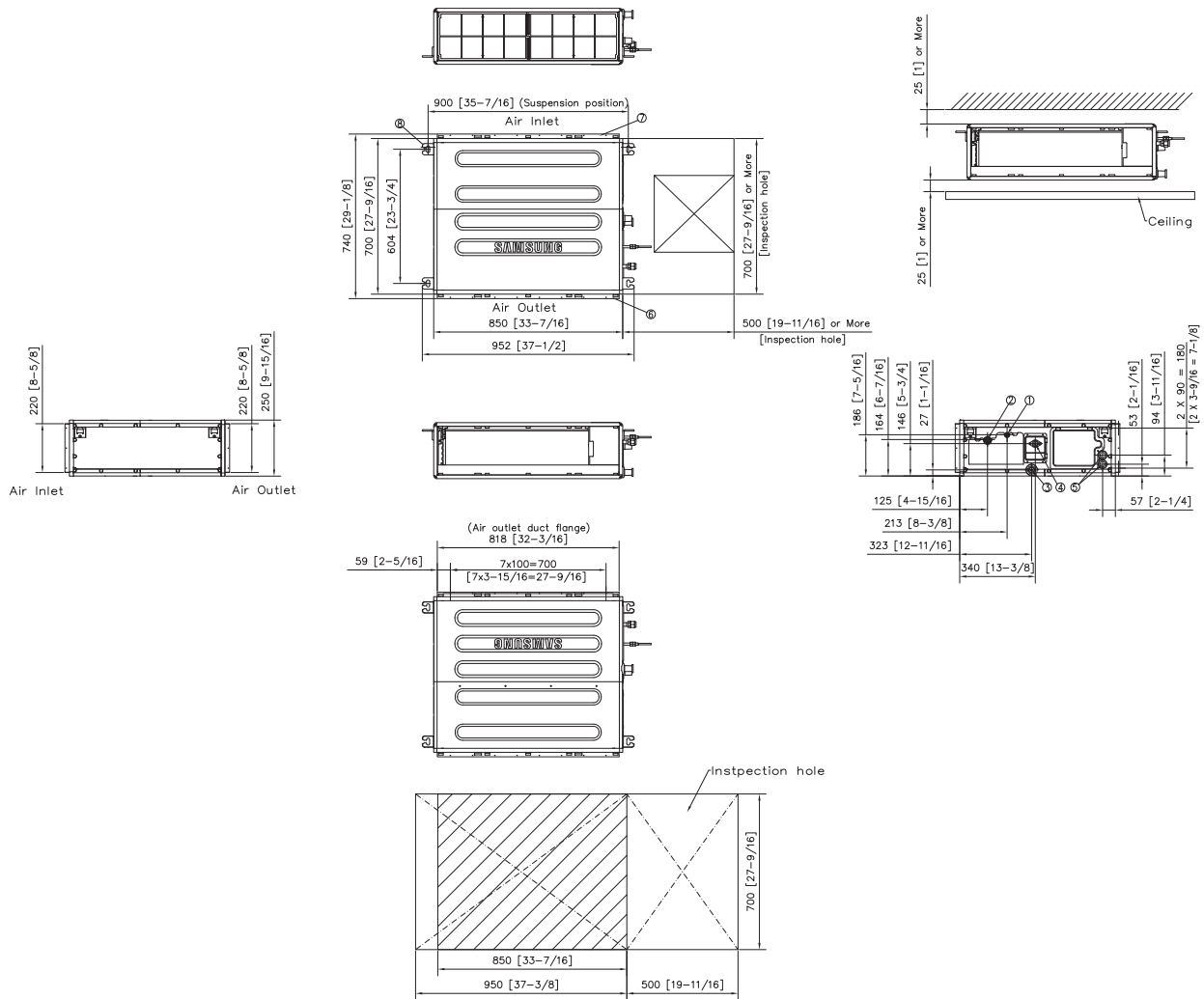

NO	Name	Description
		AM022DNMDKG/EU, AM028DNMDKG/EU, AM036DNMDKG/EU, AM045DNMDKG/EU, AM056DNMDKG/EU
		AM071DNMDKG/EU
1	Gas pipe connection	Ø12.70 (1/2")
2	Liquid pipe connection	Ø6.35 (1/4")
3	Drain pipe connection (Without drain pump)	VP25 (OD32, ID25)
4	Drain pipe connection (With drain pump)	-
5	Power & Communication Conduits	-
6	Air discharge grille flange	-
7	Return Air Side	-
8	Hook	Ø9.52 or M10

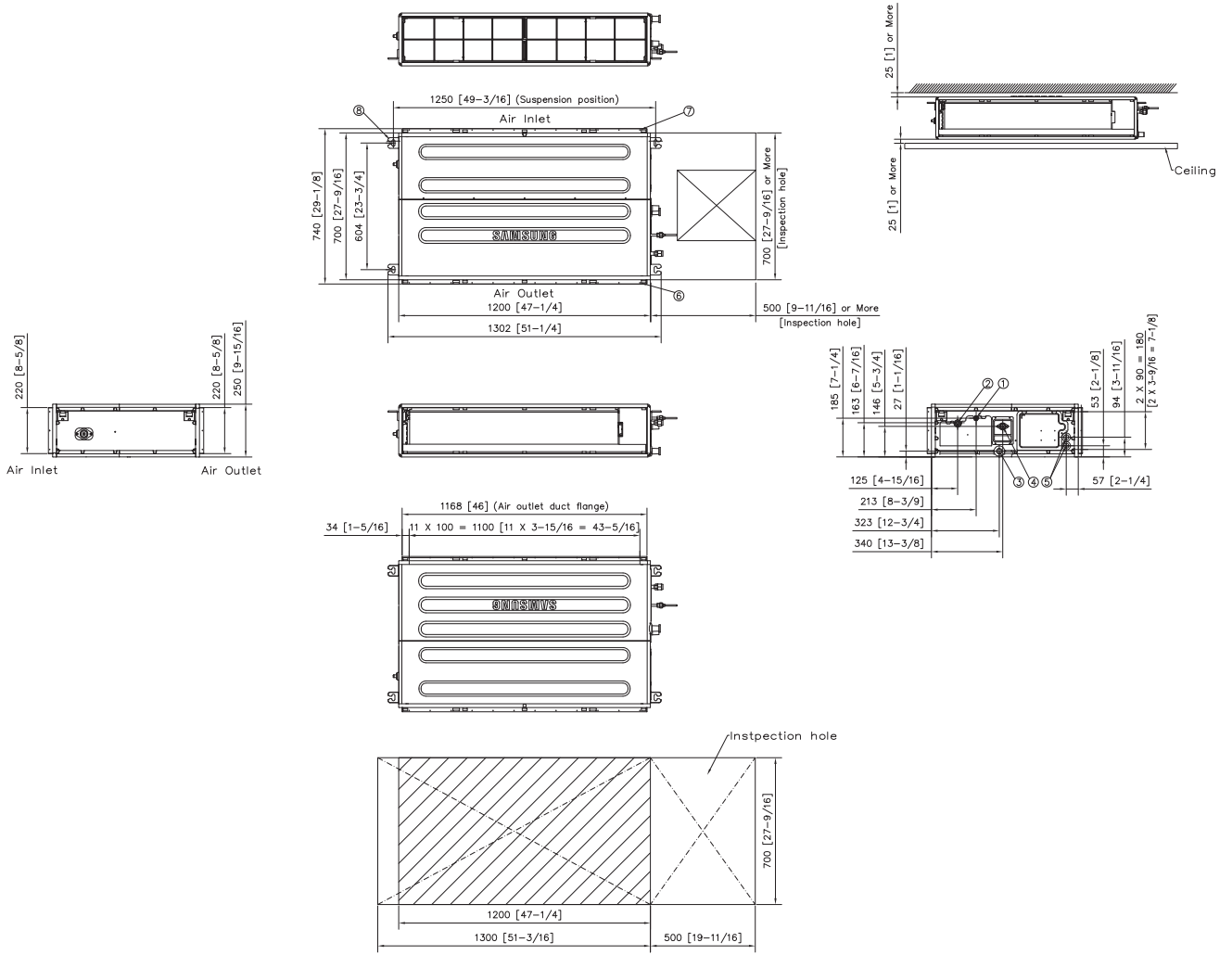

NO	Name	Description
		AM022DNMFKG/EU, AM028DNMFKG/EU, AM036DNMFKG/EU, AM045DNMFKG/EU
		AM090DNMDKG/EU
1	Gas pipe connection	Ø12.70 (1/2")
2	Liquid pipe connection	Ø6.35 (1/4")
3	Drain pipe connection (Without drain pump)	VP25 (OD32, ID25)
4	Drain pipe connection (With drain pump)	-
5	Power & Communication Conduits	-
6	Air discharge grille flange	-
7	Return Air Side	-
8	Hook	Ø9.52 or M10

Dimensional drawings ^{2/2}

Universal MSP Duct (drain pump included)

AM112DNMDKG/EU, AM128DNMDKG/EU, AM140DNMDKG/EU, AM160DNMDKG/EU, AM056DNMFKG/EU, AM071DNMFKG/EU

Units: mm [inches]

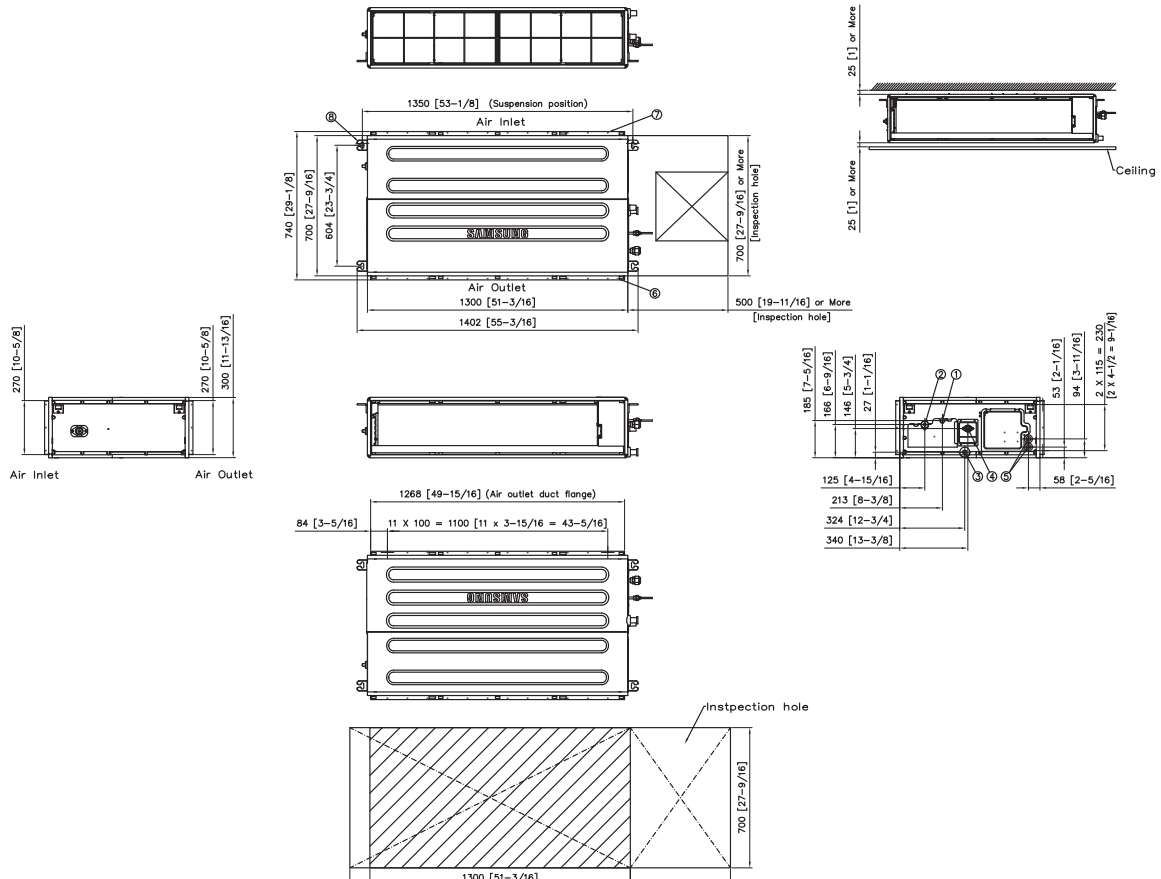

NO	Name	Description
		AM056DNMFKG/EU
		AM112DNMDKG/EU, AM128DNMDKG/EU, AM140DNMDKG/EU, AM160DNMDKG/EU, AM071DNMFKG/EU
1	Gas pipe connection	Ø12.70 (1/2")
2	Liquid pipe connection	Ø6.35 (1/4")
3	Drain pipe connection (Without drain pump)	VP25 (OD32, ID25)
4	Drain pipe connection (With drain pump)	-
5	Power & Communication Conduits	-
6	Air discharge grille flange	-
7	Return Air Side	-
8	Hook	Ø9.52 or M10



Dimensional drawings

Universal HSP Duct

AM090DNHDKG/EU

Units: mm [inches]

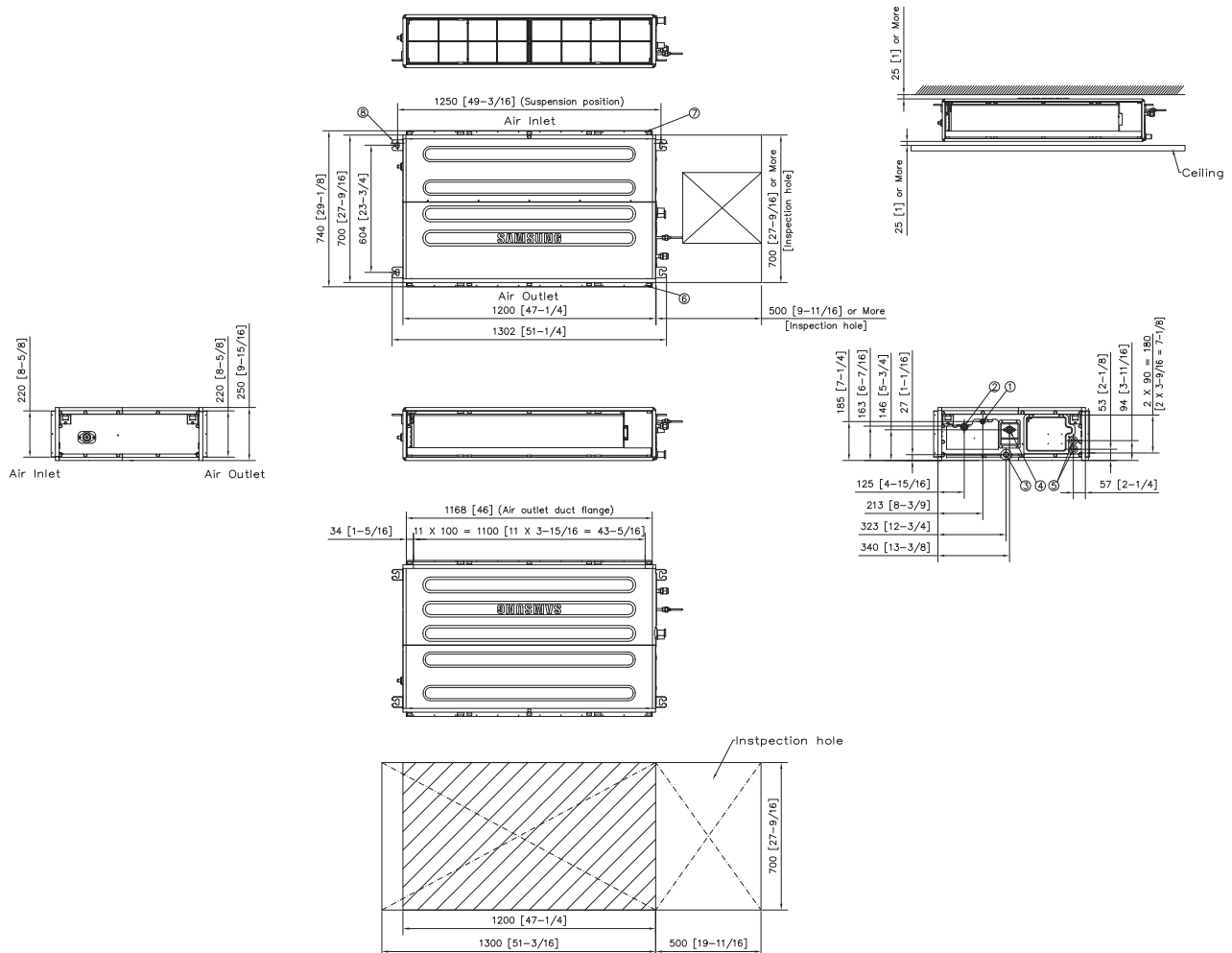

NO	Name	Description
1	Liquid pipe connection	Ø9.52 (3/8)
2	Gas pipe connection	Ø15.88 (5/8)
3	Drain pipe connection (Without drain pump)	VP25 (OD 32, ID 25)
4	Drain pipe connection (With drain pump)	-
5	Power & Communication Conduits	-
6	Air discharge grille flange	-
7	Air suction flange	-
8	Hook	Use M8-M10 bolt(4ea)

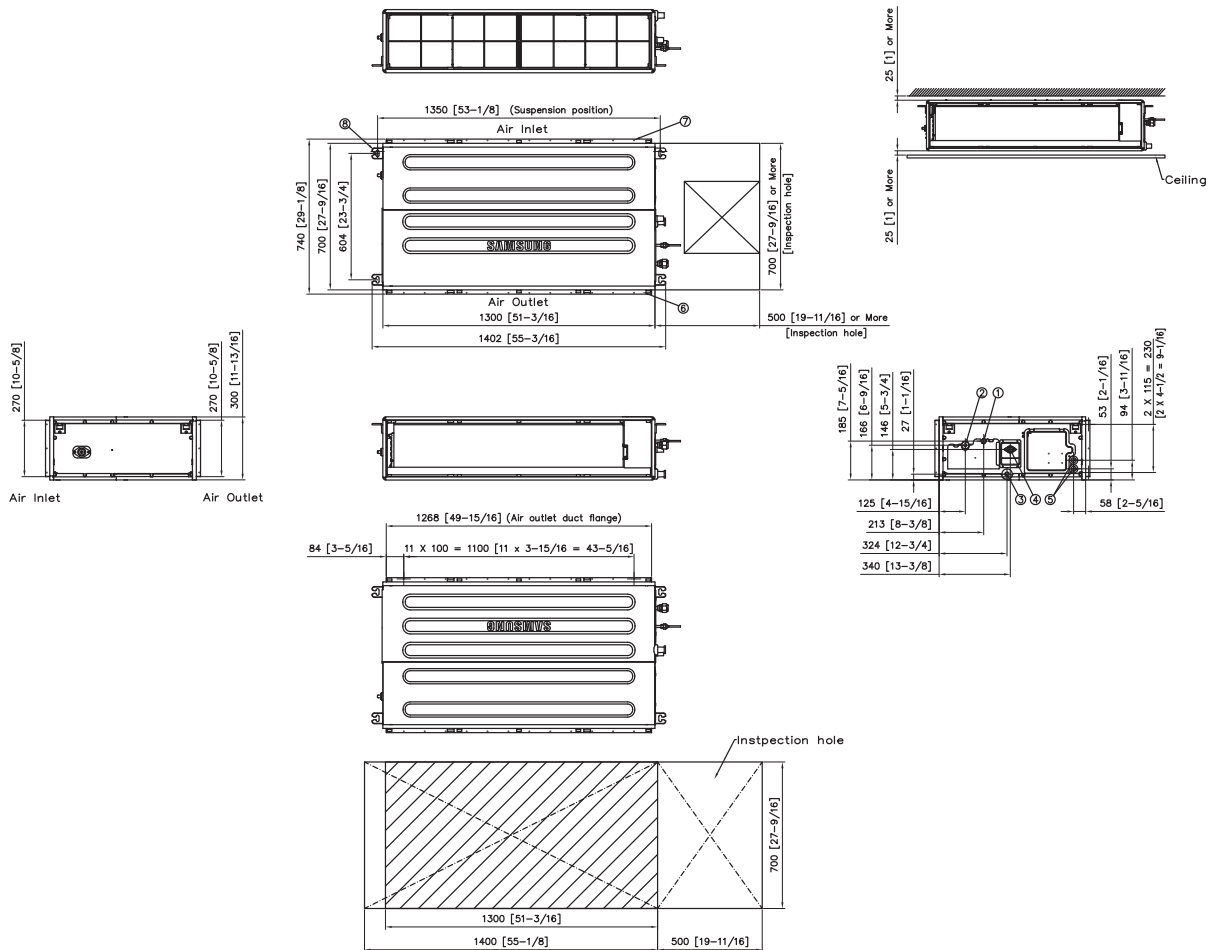

NO	Name	Description
1	Liquid pipe connection	Ø9.52 (3/8)
2	Gas pipe connection	Ø15.88 (5/8)
3	Drain pipe connection (Without drain pump)	VP25 (OD 32, ID 25)
4	Drain pipe connection (With drain pump)	-
5	Power & Communication Conduits	-
6	Air discharge grille flange	-
7	Air suction flange	-
8	Hook	Use M8-M10 bolt(4ea)

Dimensional drawings

HSP Duct (R410A)

AM180J/224JNHFKH/EU

Units: mm [inches]

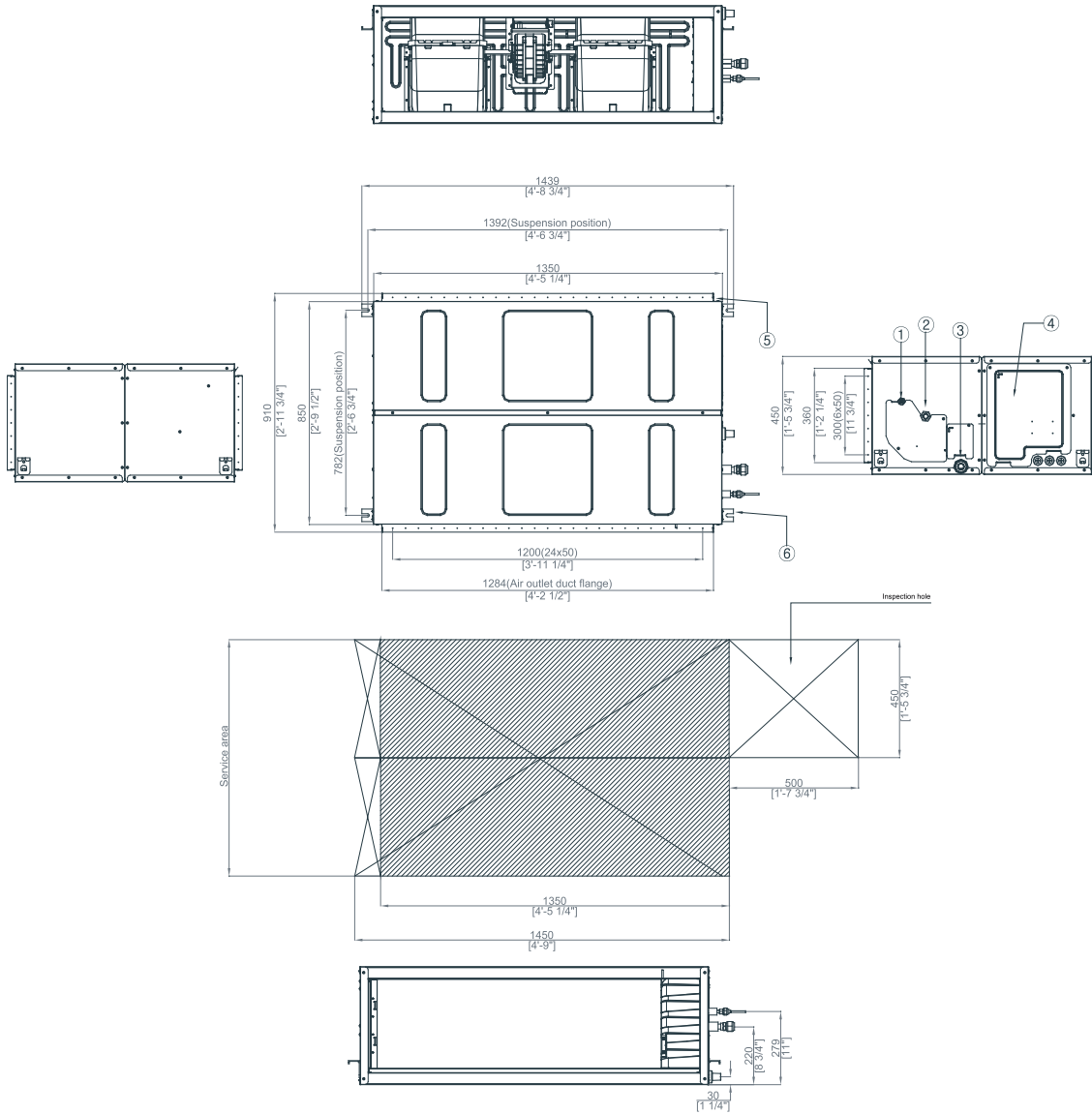

NO	Name
1	Liquid pipe connection
2	Gas pipe connection
3	Drain pipe connection
4	Power supply connetion
5	Air discharge flange
6	Hook

Dimensional drawings ^{1/2}

Console (R410A)

AM022KNJDEH/EU, AM028/036FNJDEH/EU

Units: mm [inches]

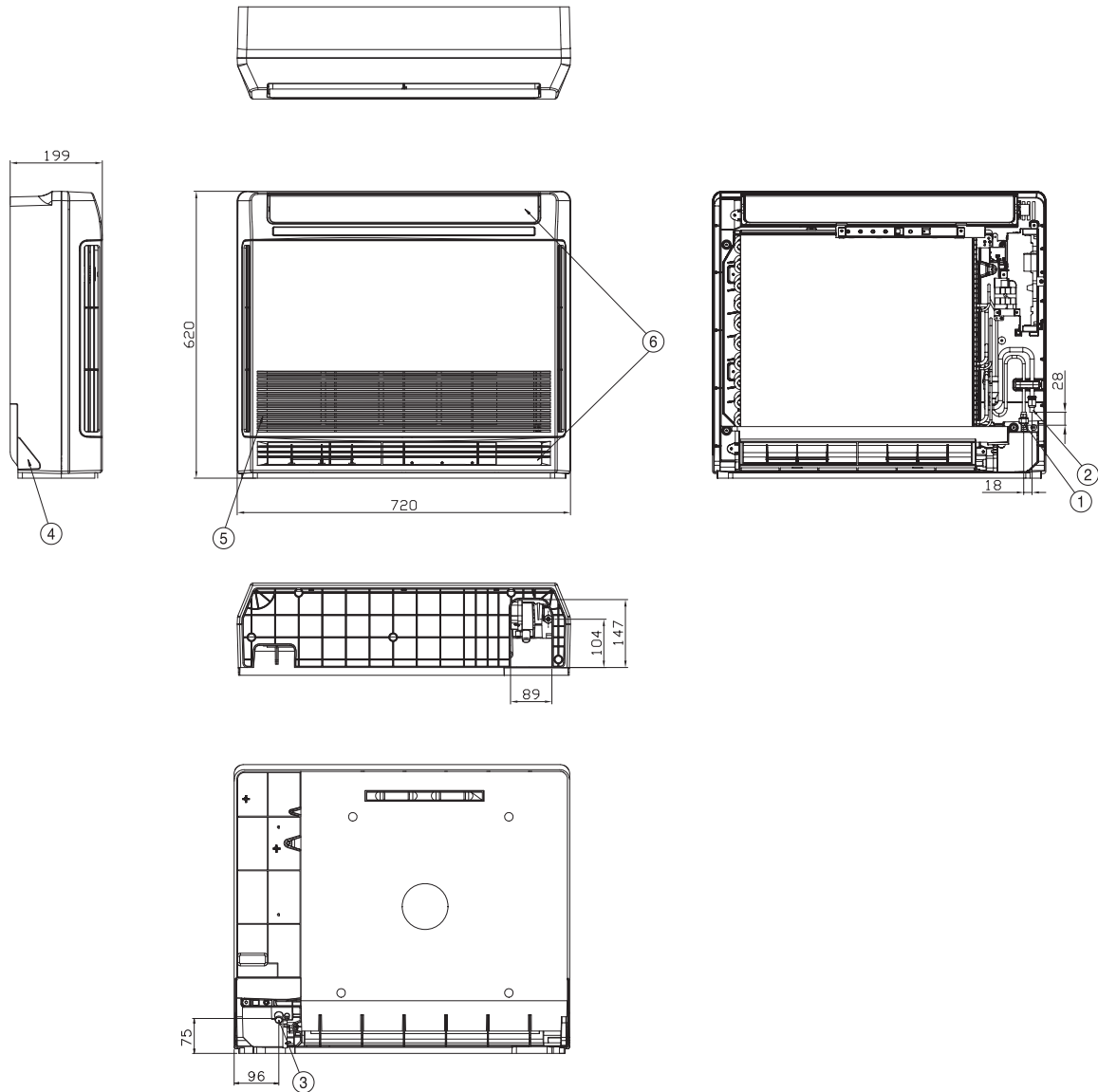

NO	Name	Description
1	Liquid pipe connection	Ø6.35 Flare
2	Gas pipe connection	Ø12.70 Flare
3	Drain pipe connection	ID 18 Hose
4	Power supply/communication wiring conduits	
5	Air inlet grille	
6	Air outlet louvre	



Dimensional drawings ^{2/2}

Console (R410A)

AM045KNJDEH/EU, AM056FNJDEH/EU

Units: mm [inches]

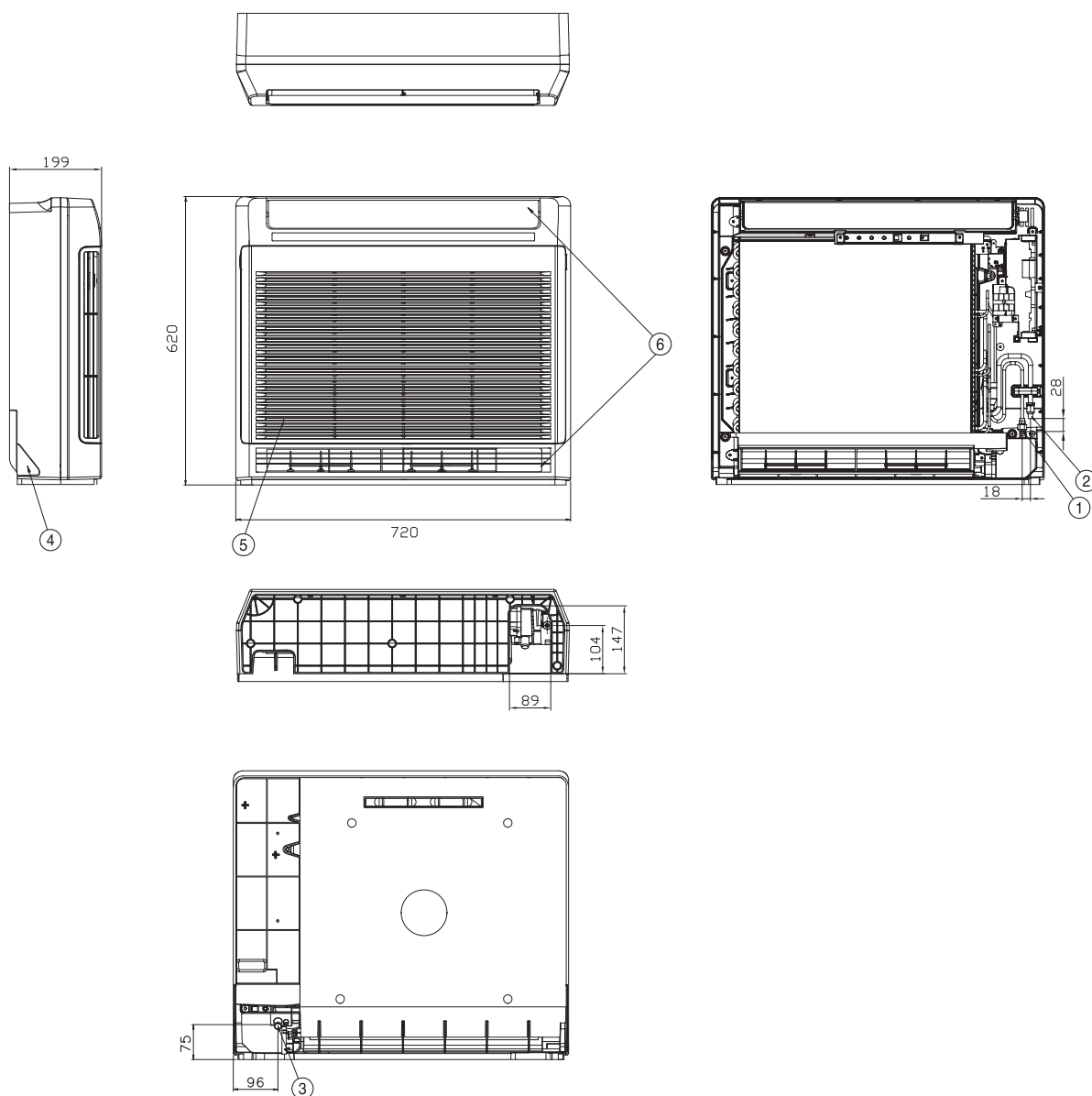

NO	Name	Description
1	Liquid pipe connection	Ø6.35 Flare
2	Gas pipe connection	Ø12.70 Flare
3	Drain pipe connection	ID 18 Hose
4	Power supply/communication wiring conduits	
5	Air inlet grille	
6	Air outlet louvre	

Dimensional drawings

Universal Floor/Ceiling

AM056DNCDKG/EU

Units: mm [inches]

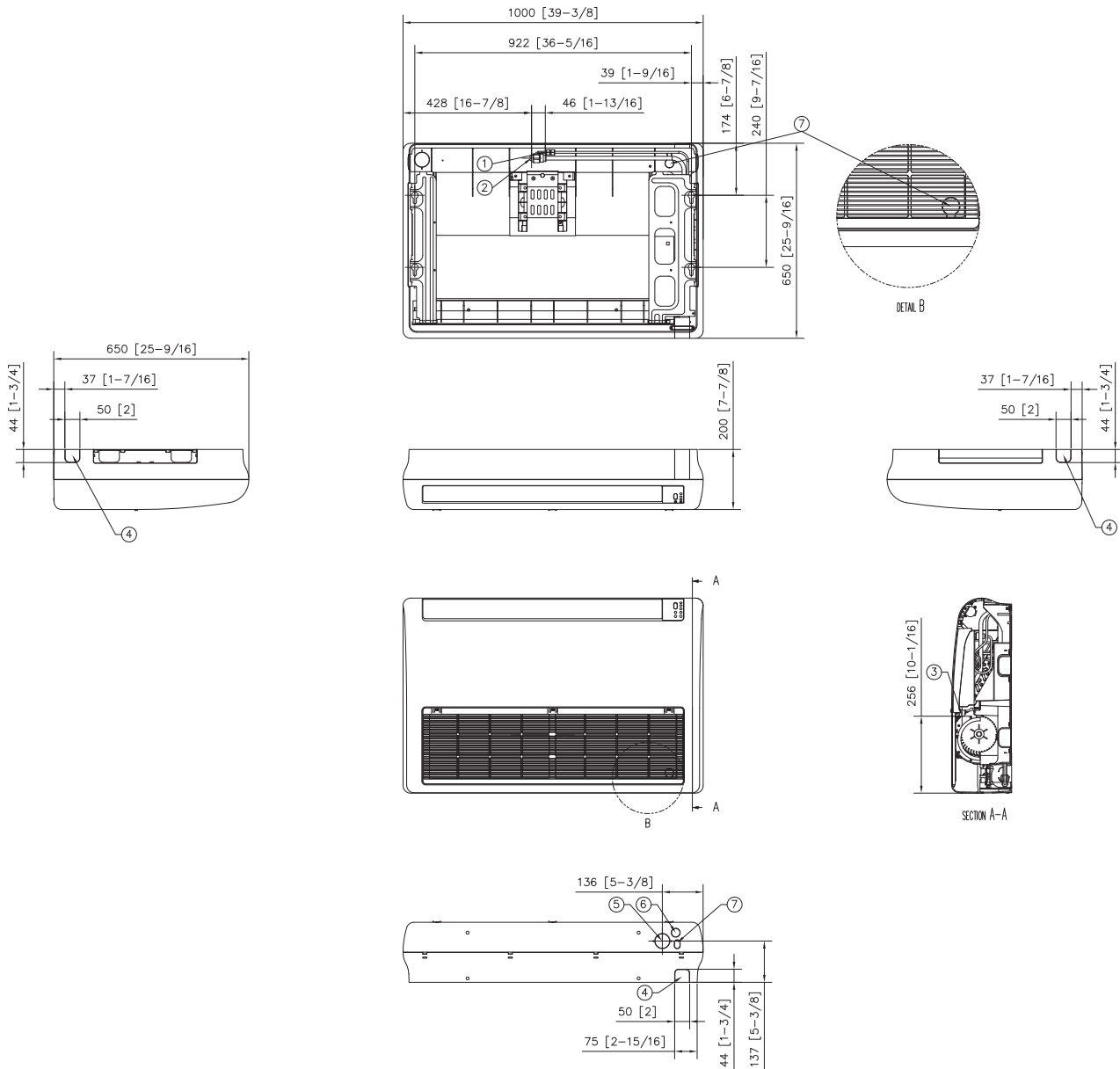

NO	Name	Description
1	Refrigerant gas pipe	Ø12.7(1/2)
2	Refrigerant liquid pipe	Ø6.35(1/4)
3	Condensate drain	ID18mm [11/16inch] Hose
4	Knockout hole for piping	
5	Knockout hole for air intake	Ø50 [2]
6	Knockout hole for drain pipe	
7	Knockout hole for wiring	

Dimensional drawings

Universal Big Ceiling

AM071DNCCKG/EU, AM112DNCCKG/EU

Units: mm [inches]

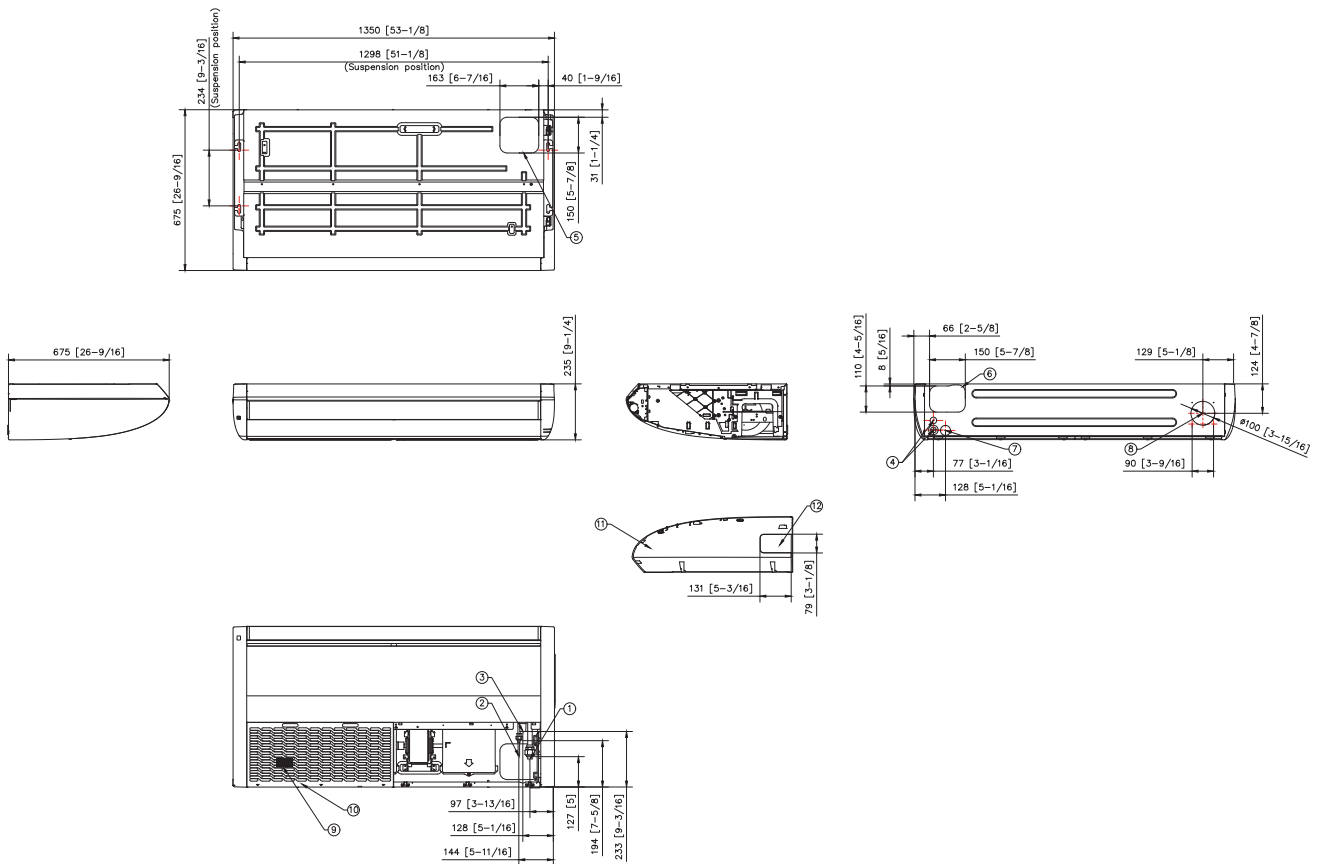

NO	Name	Description
1	Refrigerant gas pipe	$\varnothing 15.88$ (5/8)
2	Refrigerant liquid pipe	$\varnothing 9.52$ (3/8)
3	Condensate drain	VP25 (OD32, ID25)
4	Conduit hole	$\varnothing 28$ ($\varnothing 1-1/8$)
5	Knockout hole for upper piping arrangement	
6	Knockout hole for rear piping arrangement	
7	Knockout hole for drain pipe arrangement	
8	Knockout hole for fresh air intake	$\varnothing 42$ ($\varnothing 1-5/16$)
9	Air filter	
10	Air suction grille	
11	Cover side	
12	Knockout hole for side piping arrangement	

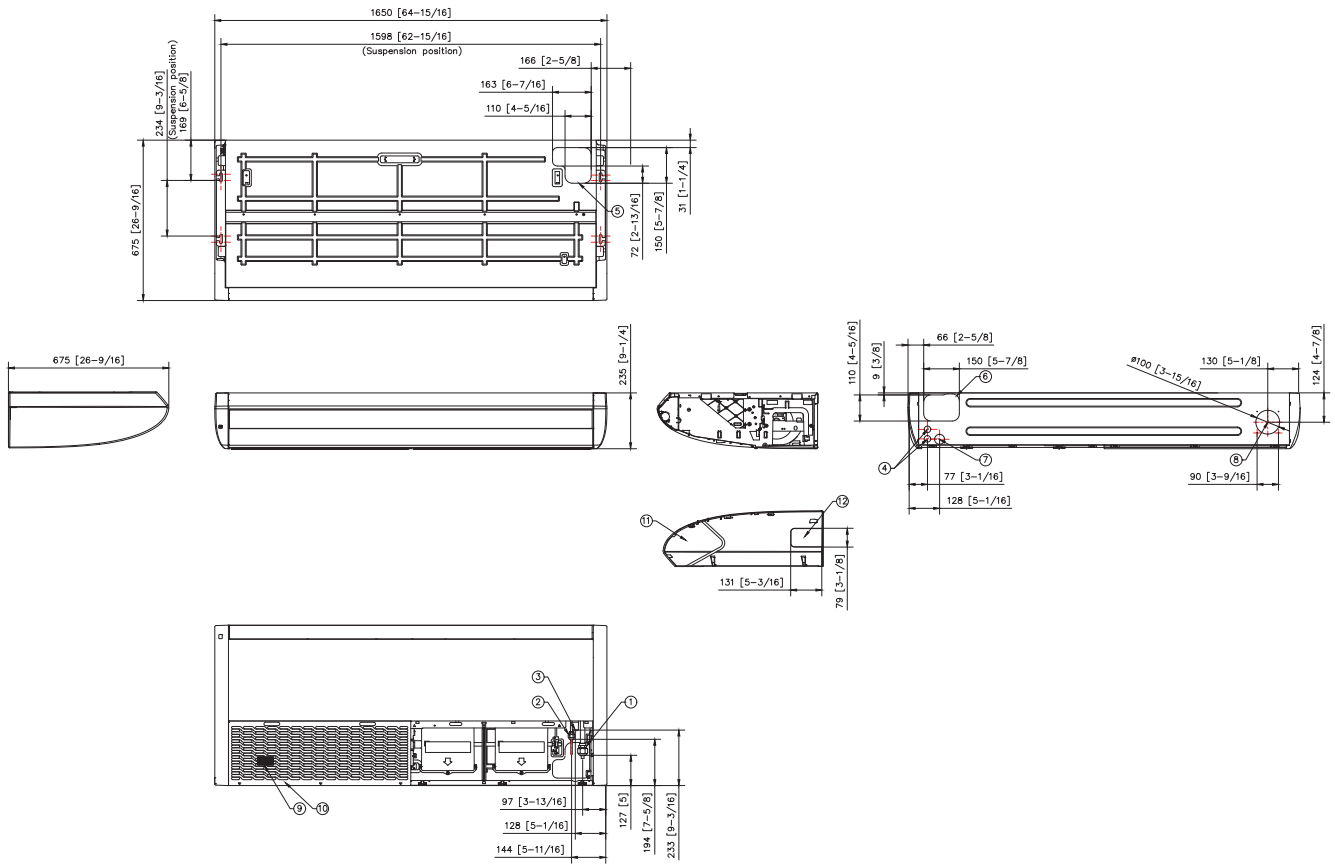

NO	Name	Description
1	Gas pipe connection	$\varnothing 15.88$ (5/8)
2	Liquid pipe connection	$\varnothing 9.52$ (3/8)
3	Drain pipe connection	VP25 (OD32, ID25)
4	Conduit hole	$\varnothing 28$ ($\varnothing 1-1/8$)
5	Knockout hole for upper piping arrangement	
6	Knockout hole for rear piping arrangement	
7	Knockout hole for drain pipe arrangement	
8	Knockout hole for fresh air intake	$\varnothing 42$ ($\varnothing 1-5/16$)
9	Air filter	
10	Air suction grille	
11	Cover side	
12	Knockout hole for side piping arrangement	

Dimensional drawings

Concealed Floor-Standing (R410A)

AM036/056/071FNFDEH/**

Units: mm [inches]

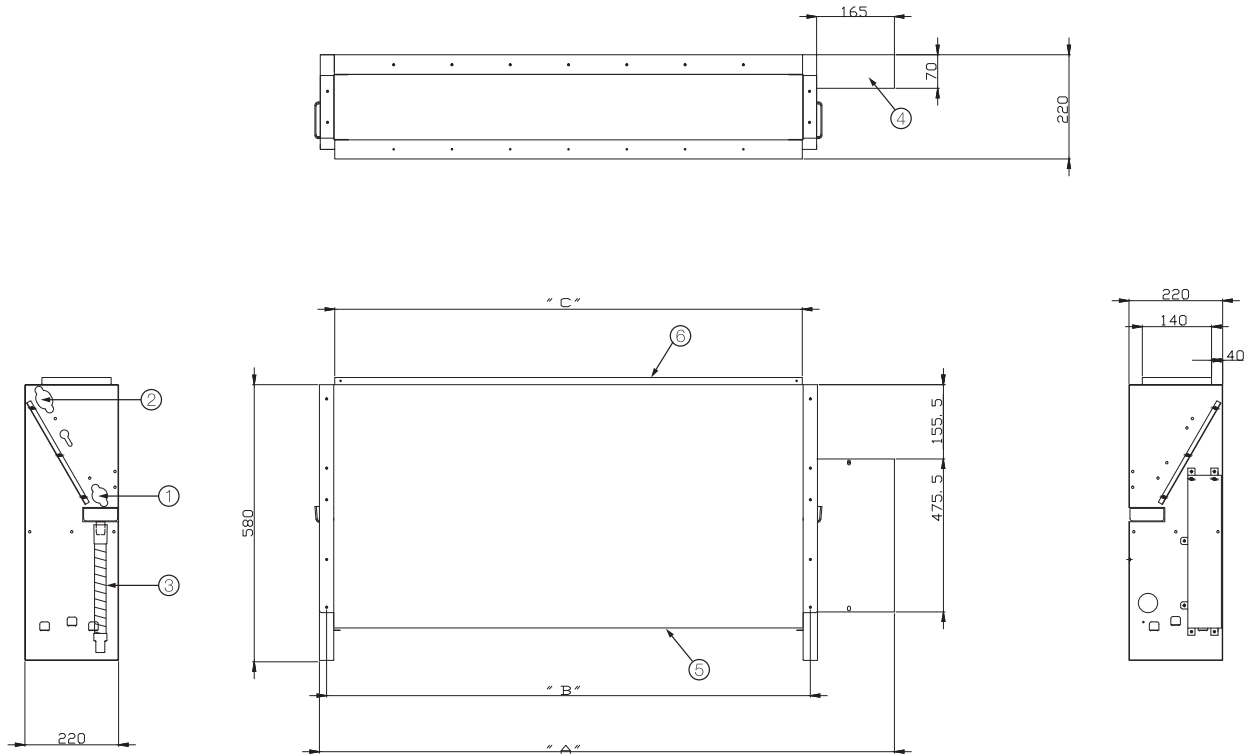

Model	A	B	C
AM036FNFDEH/EU	945	730	700
AM056/071FNFDEH/EU	1,225	1,010	980

NO	Name	Description		
		3.6 kW	5.6 kW	7.1 kW
1	Liquid pipe connection	Ø6.35 Flare	Ø6.35 Flare	Ø9.52 Flare
2	Gas pipe connection	Ø12.70 Flare	Ø12.70 Flare	Ø15.88 Flare
3	Drain pipe connection		ID 18 Hose	
4	Power supply/communication wiring conduits			
5	Air inlet grille			
6	Air outlet louvre			

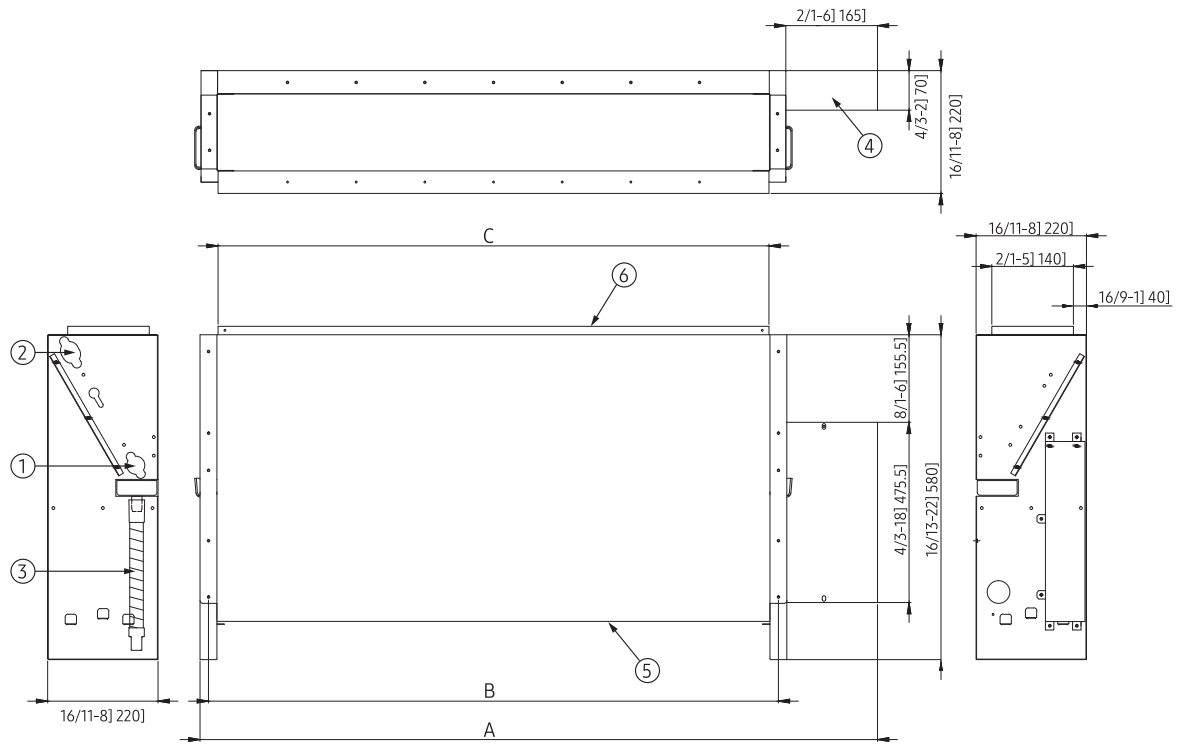

Model	A	B	C
AM036MNFDEH/EU	945	730	700
AM056/071MNFDEH/EU	1,225	1,010	980

NO	Name	Description		
		3.6 kW	5.6 kW	7.1 kW
1	Liquid pipe connection	Ø6.35 Flare	Ø6.35 Flare	Ø9.52 Flare
2	Gas pipe connection	Ø12.70 Flare	Ø12.70 Flare	Ø15.88 Flare
3	Drain pipe connection		ID 18 Hose	
4	Power supply/communication wiring conduits			
5	Air inlet grille			
6	Air outlet louvre			

Dimensional drawings

Packaged Floor-Standing (R410A)

AM140RNPDKH/EU

Units: mm [inches]

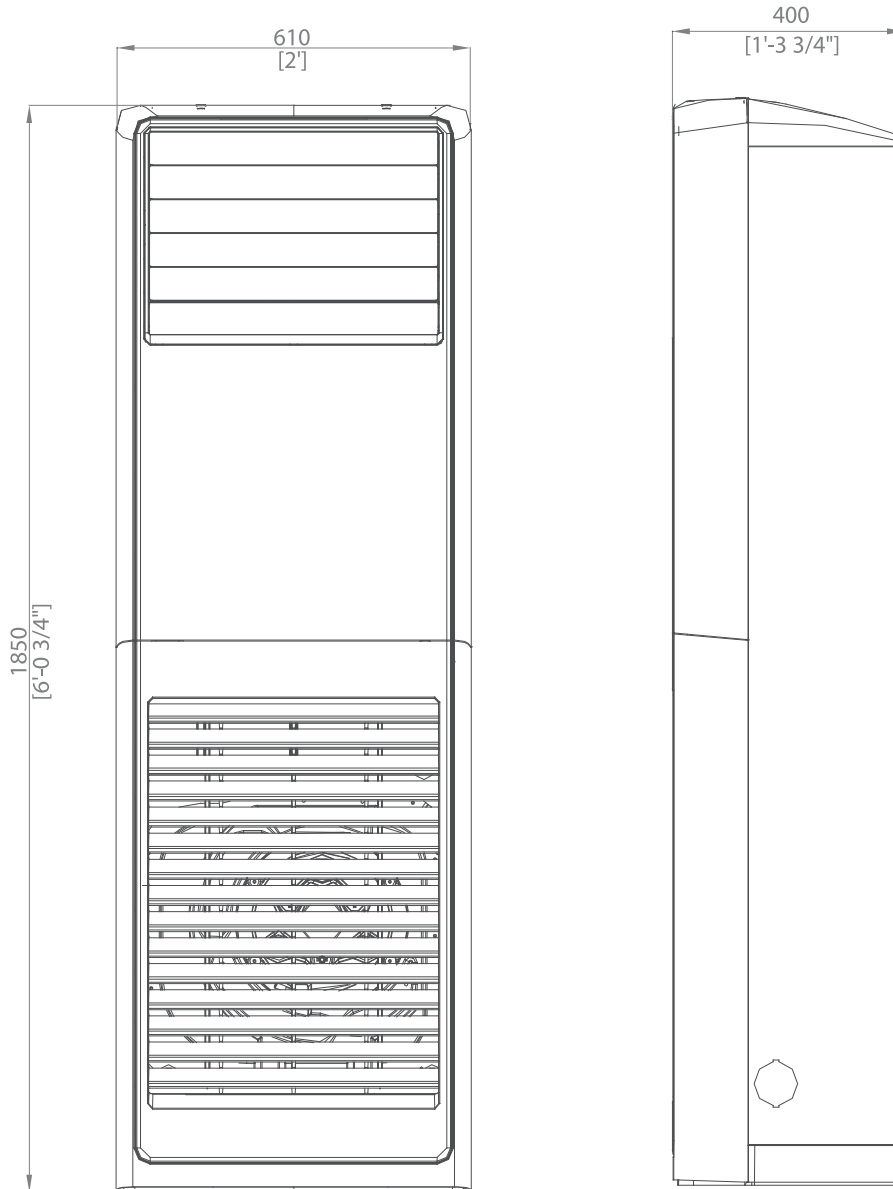

NO	Name	Description
1	Gas piping refrigerant	Ø15.88 (5/8)
2	Liquid piping refrigerant	Ø9.52 (3/8)
3	Condensation drain piping	-

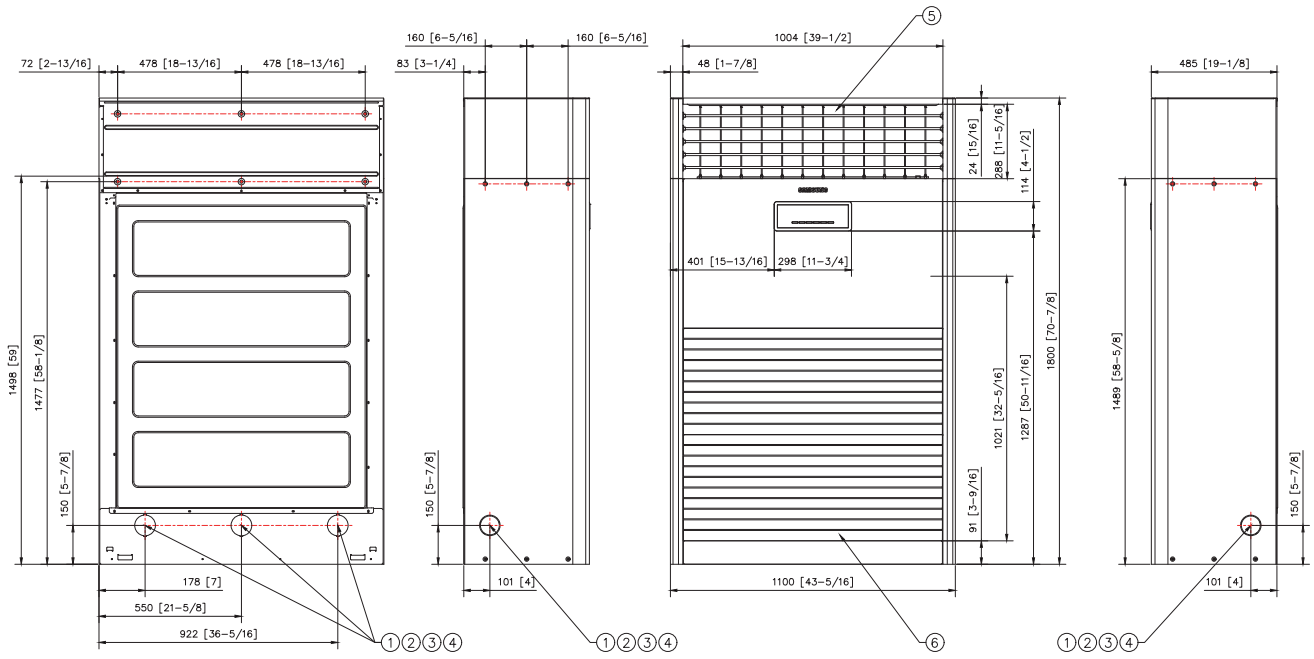

NO	Name	Description
1	Gas pipe connection	Ø22.22 [7/8]
2	Liquid pipe connection	Ø9.52 [3/8]
3	Drain hose connection	-
4	Power supply/Communication wiring conduit	-
5	Air outlet louver	-
6	Air inlet grille	-

Dimensional drawings

Universal WindFree™ Deluxe (EEV included)

AM015DNVDKG/EU, AM022DNVDKG/EU, AM028DNVDKG/EU, AM036DNVDKG/EU

Units: mm [inches]

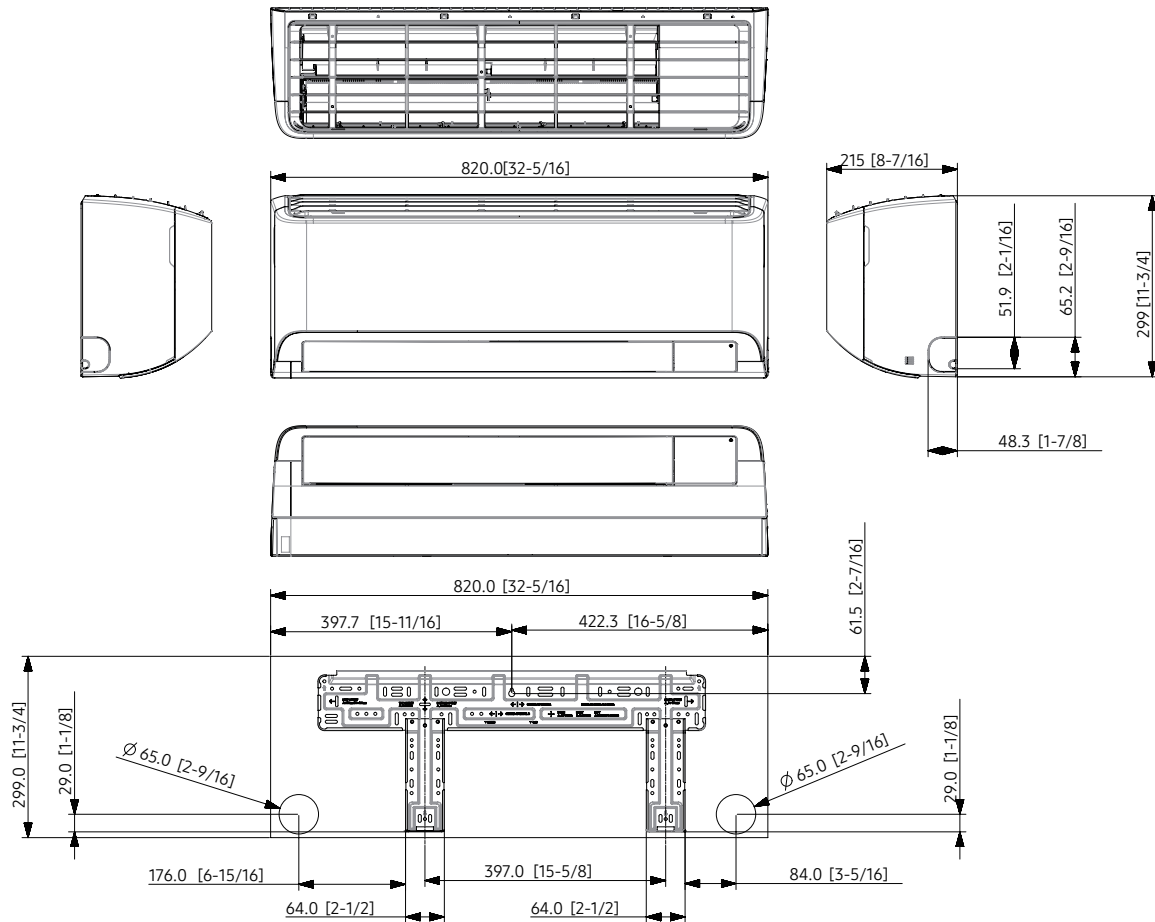

NO	Name	Description
1	Refrigerant gas pipe	$\varnothing 12.70$ (1/2) Flare
2	Refrigerant liquid pipe	$\varnothing 6.35$ (1/4) Flare
3	Drain pipe connection	ID 18 Hose

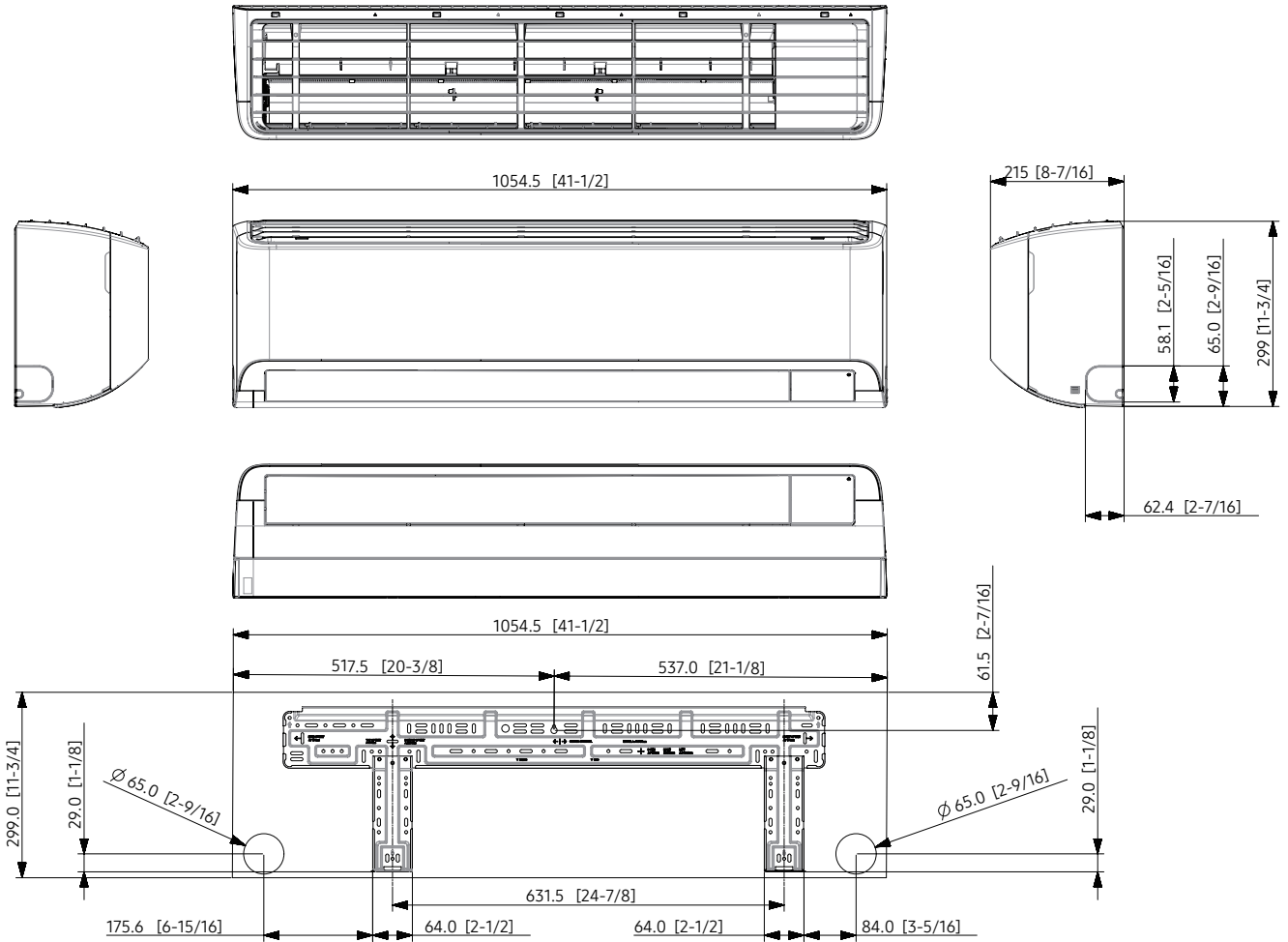

NO	Name	Description	
		AM045DNVDKG/EU AM056DNVDKG/EU	AM071DNVDKG/EU AM082DNVDKG/EU
1	Refrigerant gas pipe	Ø12.70 (1/2) Flare	Ø15.88 (5/8) Flare
2	Refrigerant liquid pipe	Ø6.35 (1/4) Flare	Ø9.52 (3/8) Flare
3	Drain pipe connection	ID 18 Hose	ID 18 Hose

Dimensional drawings

WindFree™ Deluxe (EEV excluded, R410A)

AM015TNADKH/EU, AM022TNADKH/EU, AM028TNADKH/EU, AM036TNADKH/EU

Units: mm [inches]

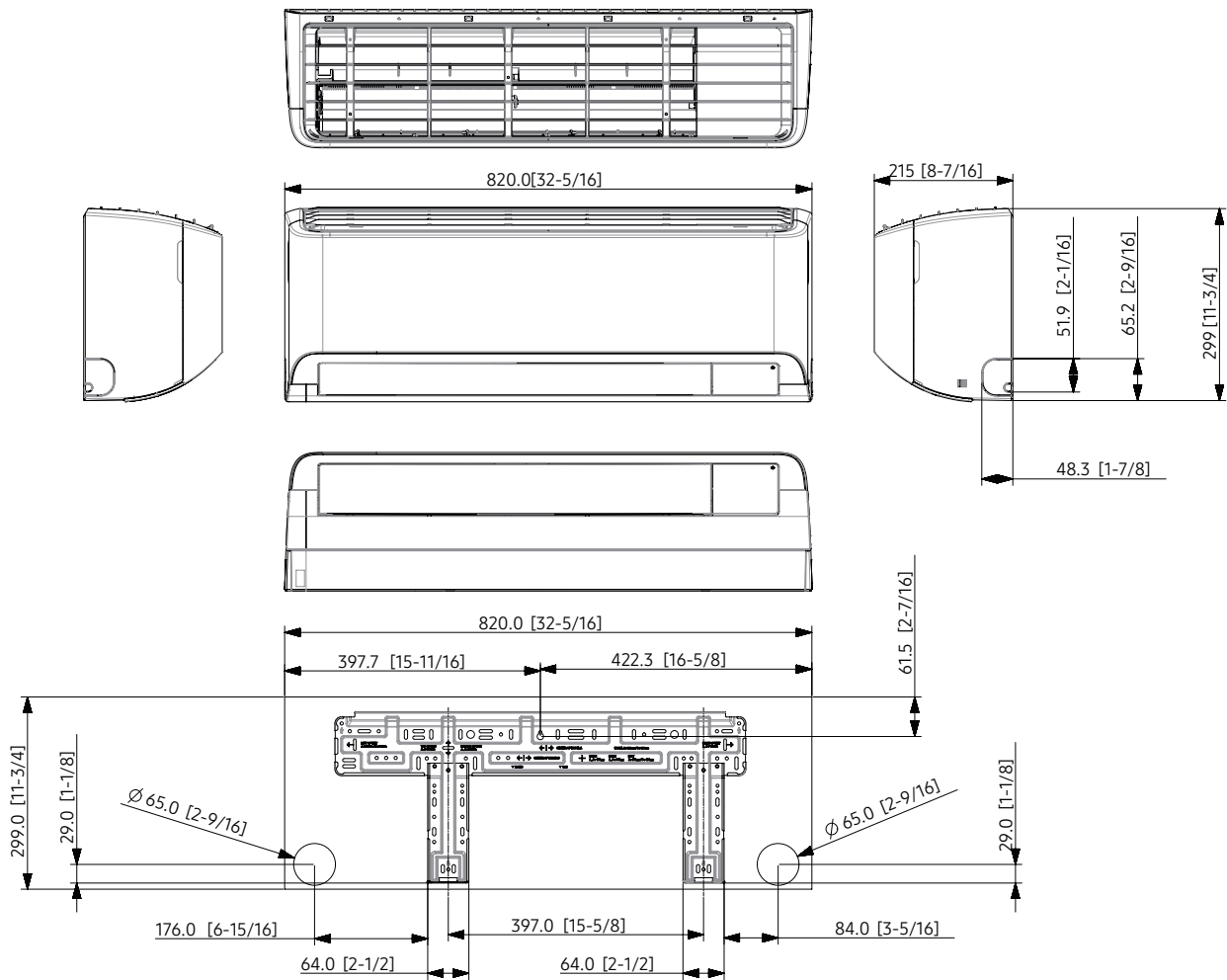

NO	Name	Description
1	Refrigerant gas pipe	$\varnothing 12.70$ (1/2) Flare
2	Refrigerant liquid pipe	$\varnothing 6.35$ (1/4) Flare
3	Drain pipe connection	ID 18 Hose

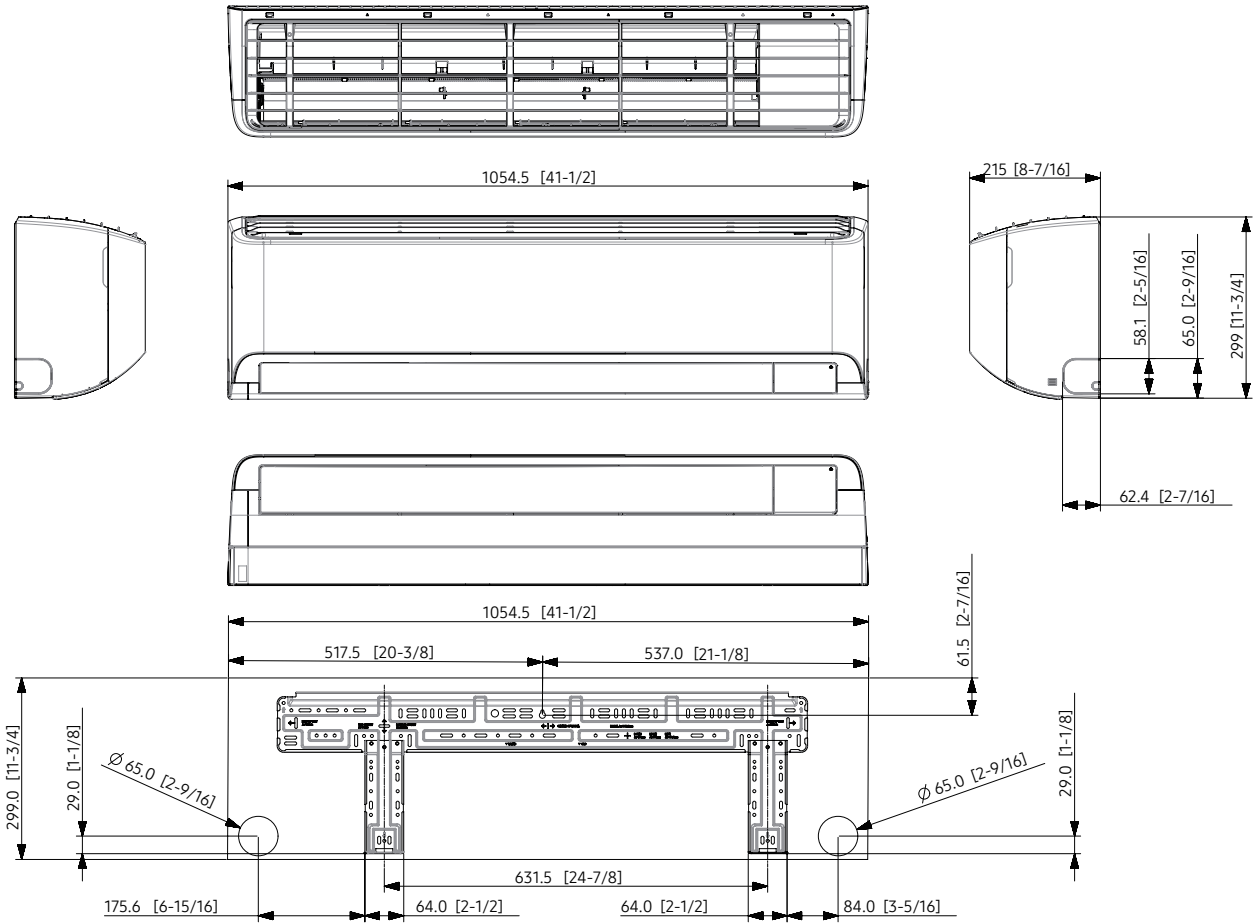

NO	Name	Description
1	Refrigerant gas pipe	$\varnothing 12.70$ (1/2) Flare
2	Refrigerant liquid pipe	$\varnothing 6.35$ (1/4) Flare
3	Drain pipe connection	ID 18 Hose

Dimensional drawings

Universal Max Wall-Mounted

AM093DNQDKG/EU

Units: mm [inches]

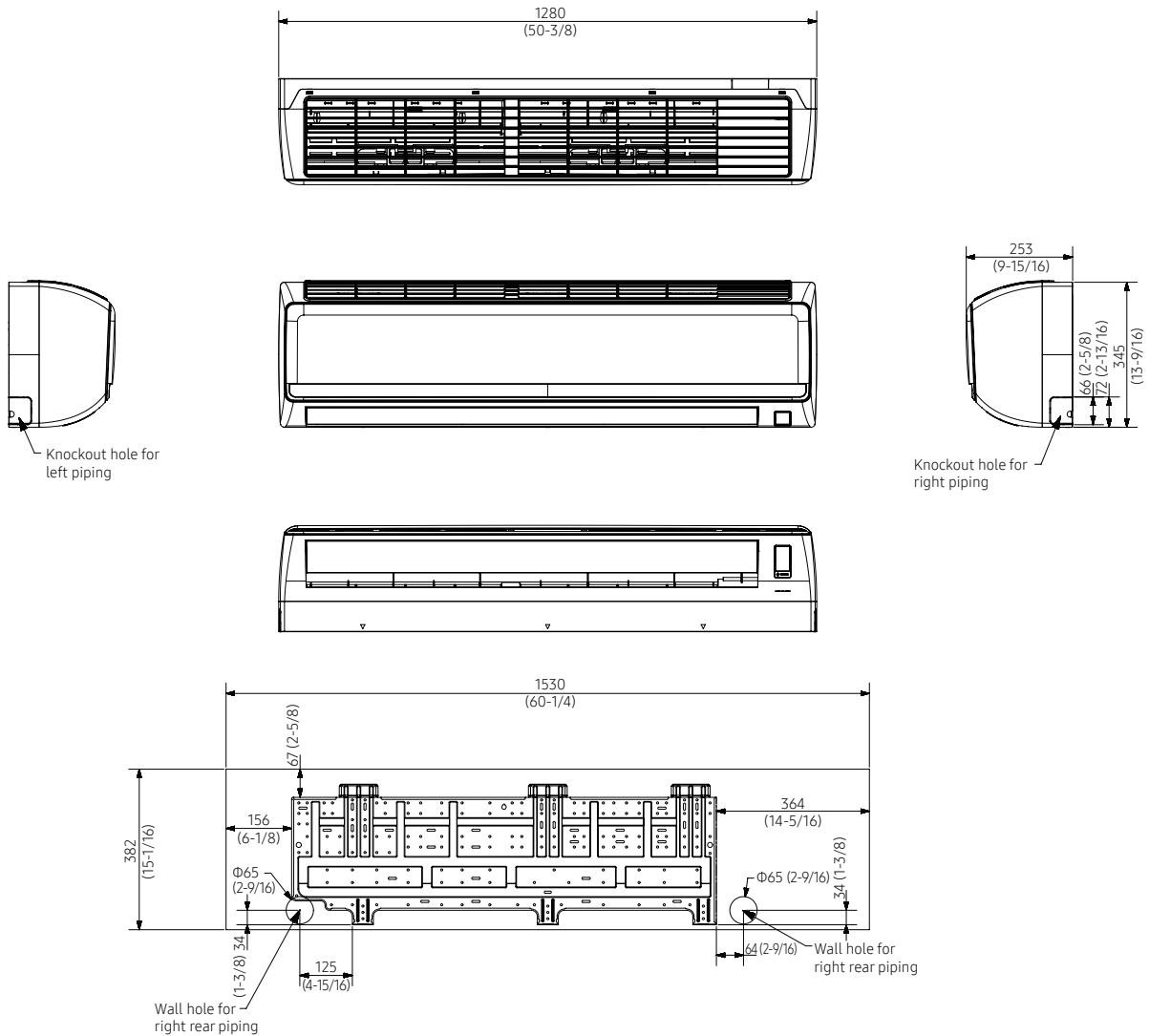

NO	Name	Description
1	Liquid pipe connection	Ø9.52 (3/8)
2	Gas pipe connection	Ø15.88 (5/8)
3	Drain pipe connection	ID 18 HOSE
4	Power supply/communication wiring conduits	-



Dimensional drawings

Hydro Unit (R410A)

AM***FNBDEH/EU

Units: mm [inches]

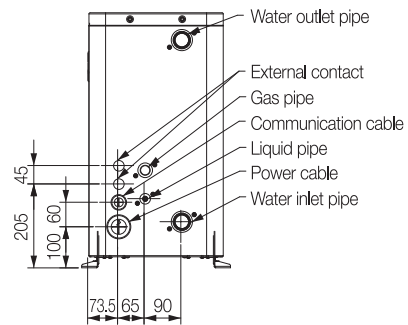
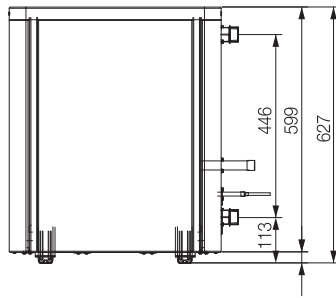
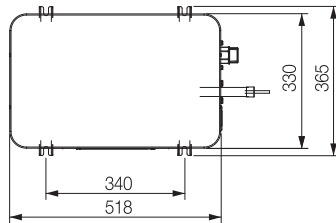

AM***TNBF*B/EU

Units: mm [inches]

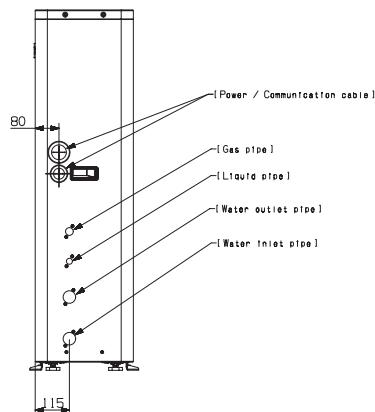
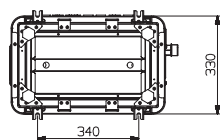
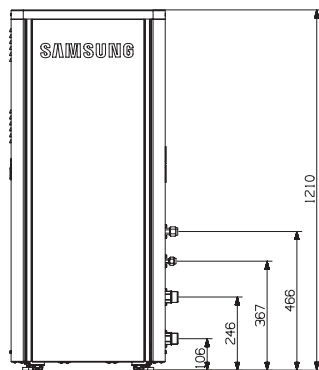
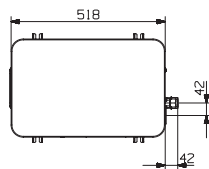

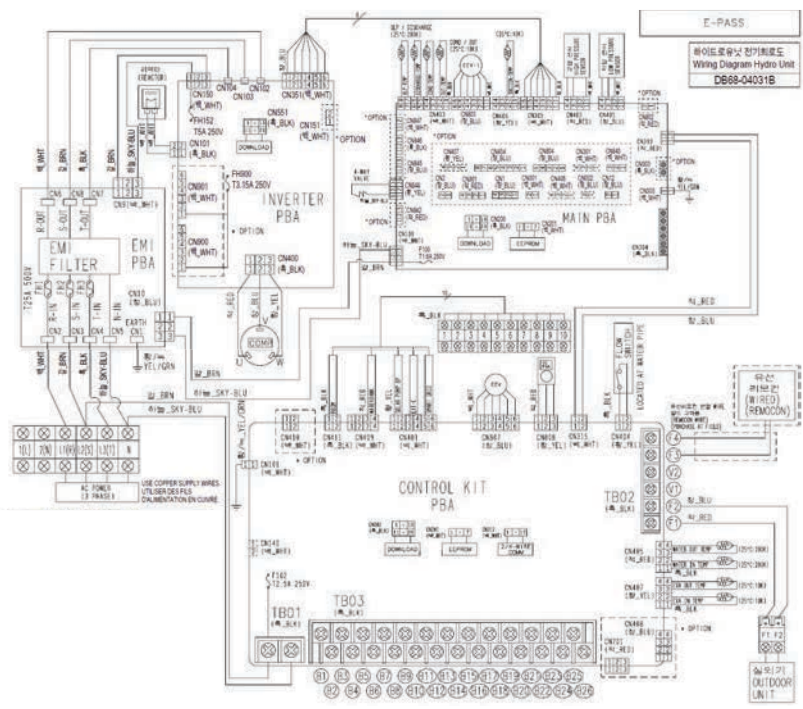
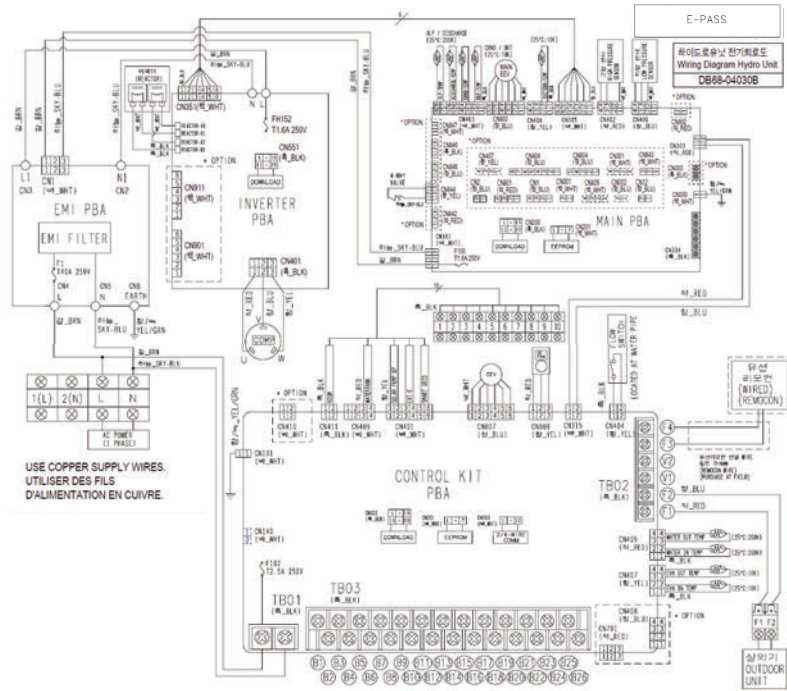

Dimensional drawings ^{1/4}

Mode Control Unit (MCU, R410A)

MCU-R4NEK0N

Units: mm [inches]

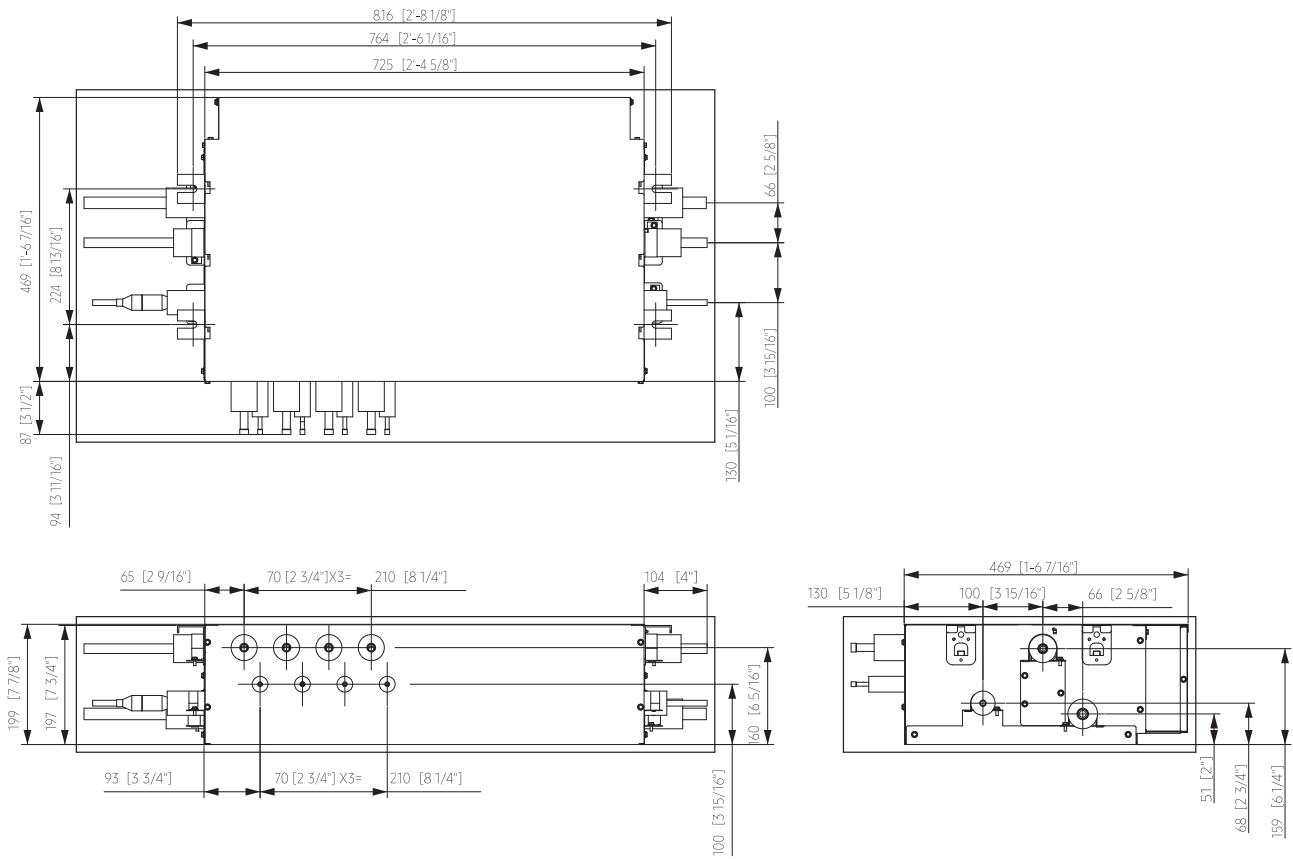

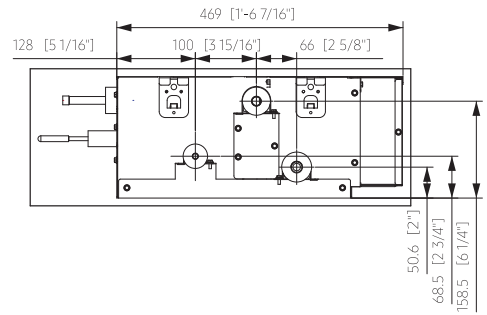
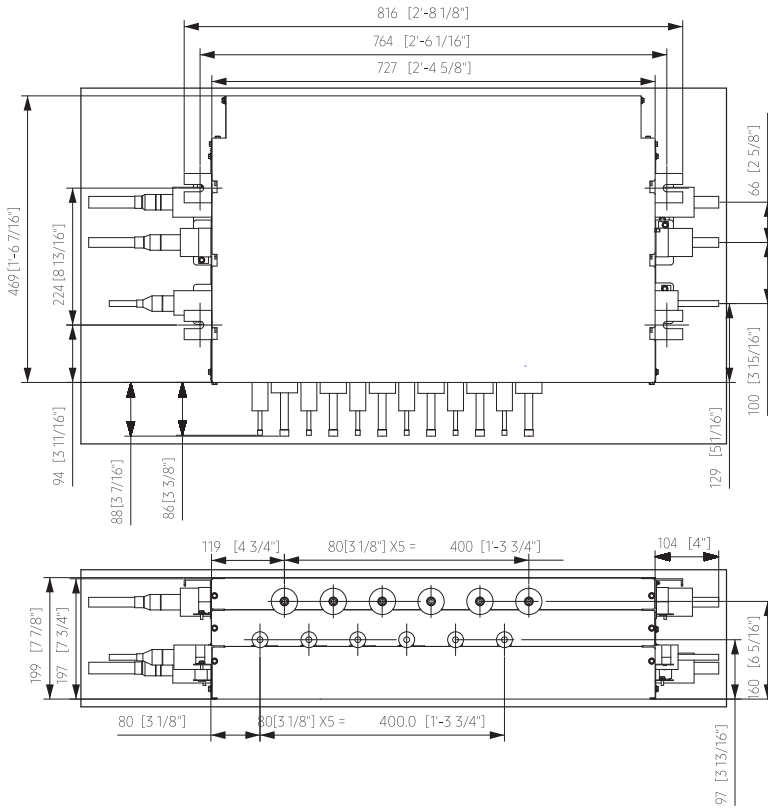

Dimensional drawings 2/4

Mode Control Unit (MCU, R410A)

MCU-S1NEK1N

Units: mm [inches]

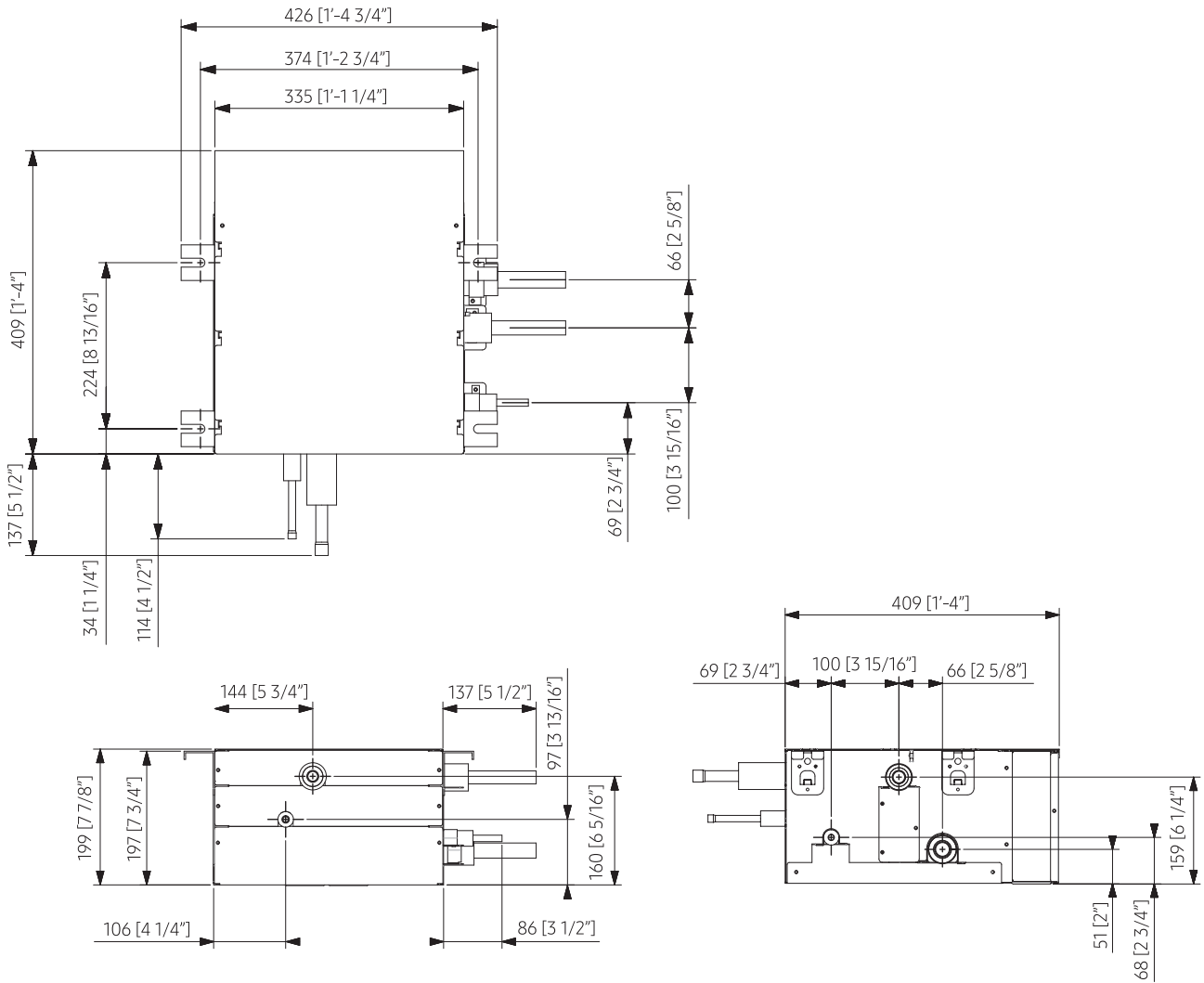

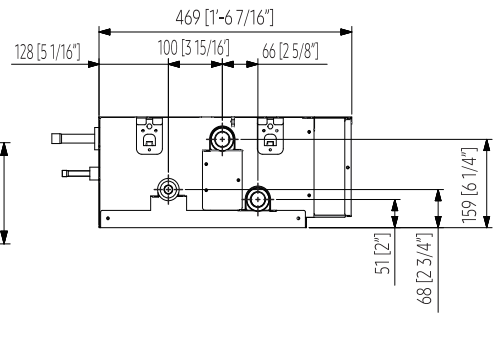
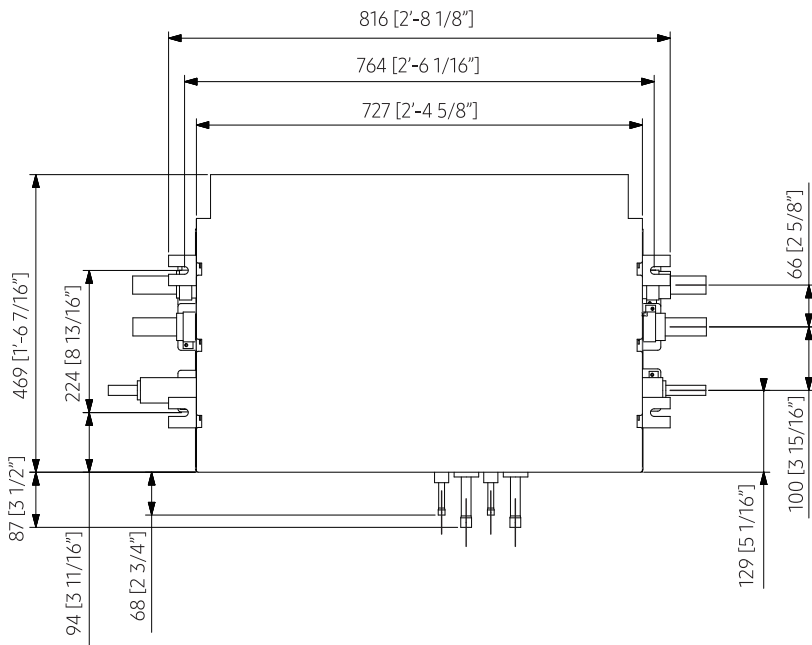

Dimensional drawings ^{3/4}

Mode Control Unit (MCU, R410A)

MCU-S4NEK3N

Units: mm [inches]

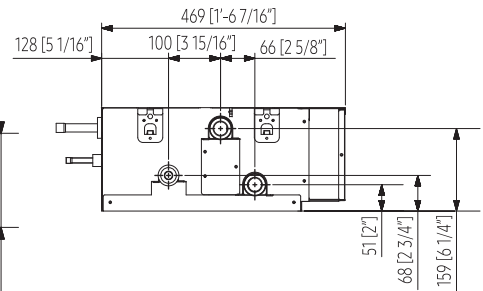
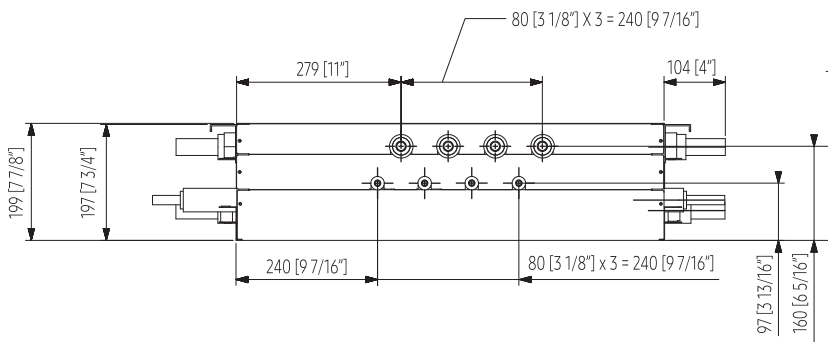
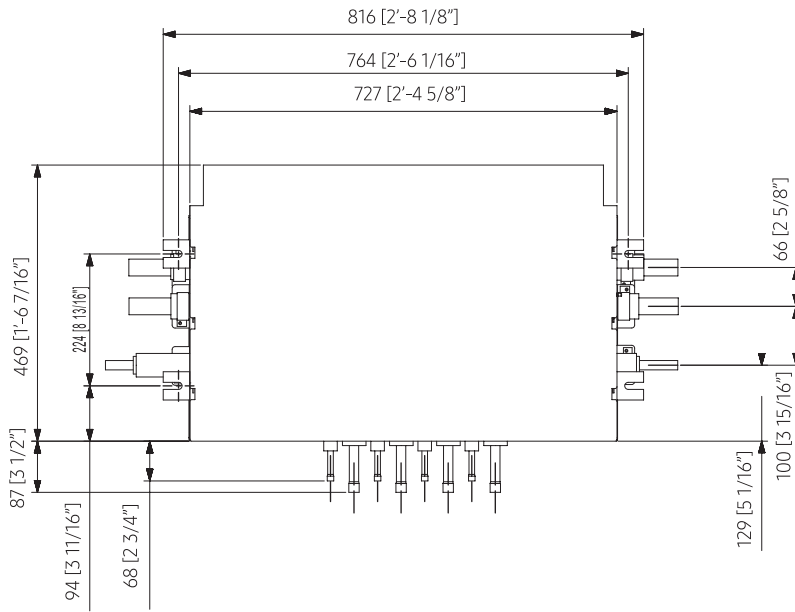

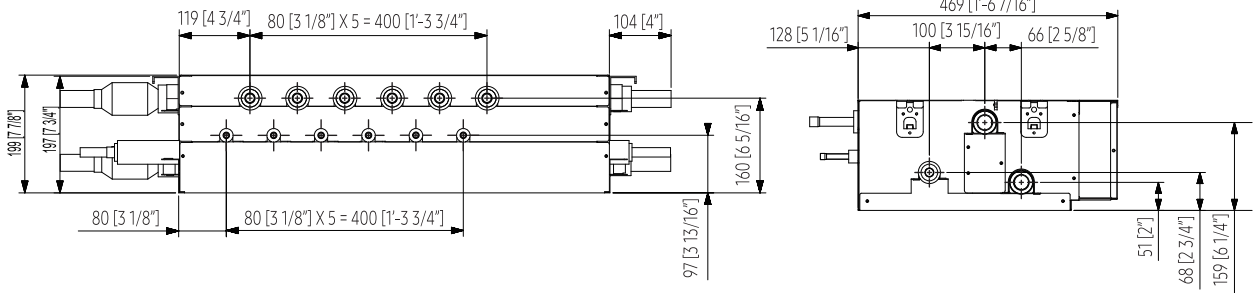
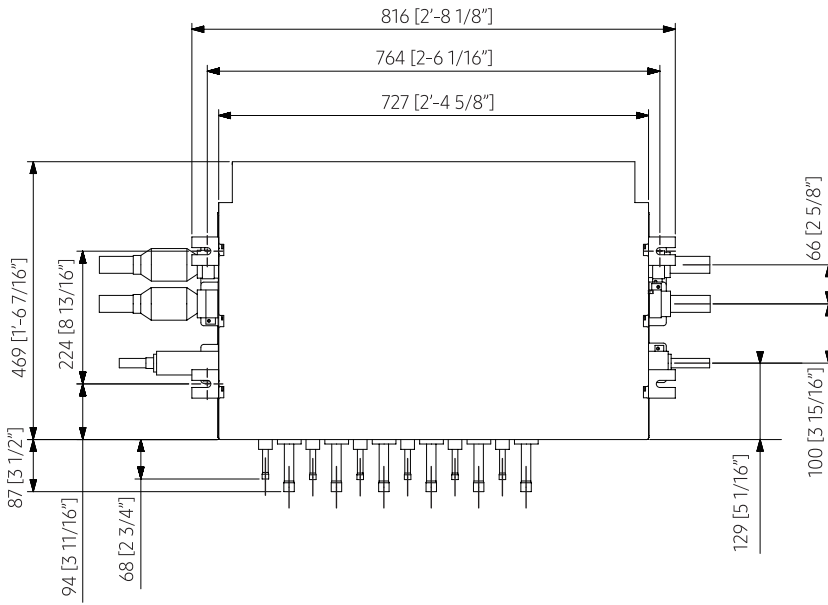

Dimensional drawings 4/4

Mode Control Unit (MCU, R410A)

MCU-S8NEK1N

Units: mm [inches]

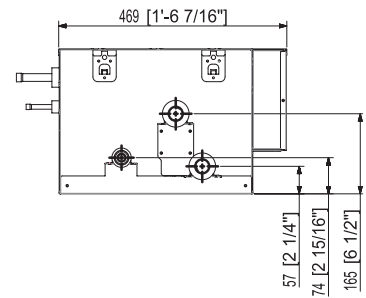
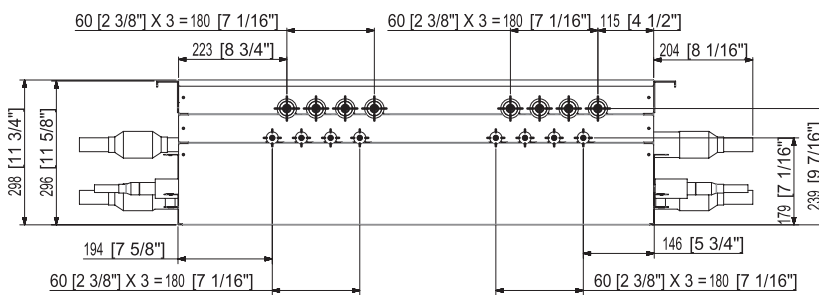
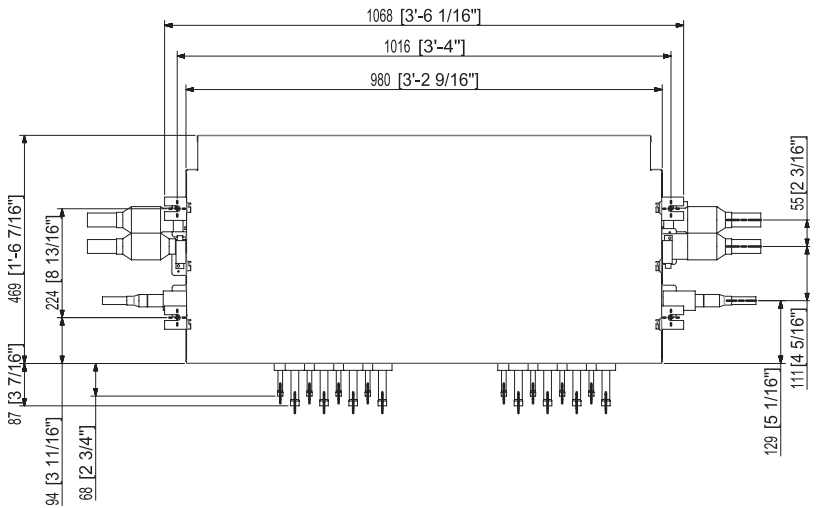

VRF Chillers

HVM: water-based cooling and heating of individual zones

A Hydro Variable Multi (HVM) system combines the benefits of VRF and Chiller technologies to provide a water-based solution for retrofit and new design projects.

It is an air-to-water heat pump that can be connected via water piping to a variety of indoor Fan Coil Units (FCUs) such as the 360 Cassette or a one-Way cassette, to provide cooling and heating to individual zones. An HVM system can also be connected to thermal storage systems and hot water systems.





Line-up outdoor

Model Type	Image	42 kW	56 kW	65 kW
Standard model (pump excluded)		AG042KSVANH/EU AG042FAVANG/EU R32 NEW	AG056KSVANH/EU AG056FAVANG/EU R32 NEW	AG070KSVANH/EU

Combining modules allows each product to work at high capacity. You can combine up to 16 modules.

Combination guide





outdoor

Modulation guide

Total Capacity (kW)	Model			Suggested Ø water type controller piping
	AG042	AG056	AG070	
42	1			40
56		1		40
65			1	50
84	2			50
112		2		65
126	3			65
130			2	80
168		3		80
168 (high efficiency)	4			80
195			3	80
210	5			80
224		4		100
252	6			100
260			4	100
280		5		100
294	7			100
325			5	100
336		6		100
336 (high efficiency)	8			100
378	9			100
390			6	100
392		7		100
420	10			100
448		8		125

Total Capacity (kW)	Model			Suggested Ø water type controller piping
	AG042	AG056	AG070	
455			7	125
462	11			125
504		9		125
504 (high efficiency)	12			125
520			8	125
546	13			125
560		10		125
585			9	125
588	14			125
616		11		125
630	15			125
650			10	125
672		12		125
672 (high efficiency)	16			125
715			11	150
728		13		125
780			12	150
784		14		150
840		15		150
845			13	150
896		16		150
910			14	150
975			15	150
1,040			16	150

Line-up indoor

Model Type	Image	1.9 kW	2.6 kW	3.0 kW	4.2 kW	6.0 kW	7.2 kW	7.8 kW	9.0 kW	10.0 kW
WindFree™ 1-Way Cassette FCU			•	•	•					
WindFree™ 4-Way Cassette FCU						•	•		•	•
360 Cassette FCU						•	•		•	•
Concealed FCU		•		•	•		•	•		
Cased FCU		•		•	•		•	•		

Selection guide

Cassette



Feature	WindFree™ 1-Way Cassette FCU	WindFree™ 4-Way Cassette FCU	360 Cassette FCU
Cooling capacity range (nominal)	2.6–4.15 kW	6.0–10.0 kW	6.0–10.0 kW
Heating capacity range (nominal)	2.9–5.0 kW	7.3–10.7 kW	7.3–10.7 kW
Fan motor type	BLDC	BLDC	BLDC
Drain Pump	Built-in	Built-in	Built-in
Filter	Microfibrous filter	Microfibrous filter	Microfibrous filter
3-Way Valve	Optional	Optional	Optional
2-pipe	●	●	●
4-pipe (optional)			
Installation	Horizontal	Horizontal	Horizontal

Concealed and Cased



Feature	Concealed FCU ¹	Cased FCU ¹
Cooling capacity range (nominal)	1.9–7.8 kW	1.9–7.8 kW
Heating capacity range (nominal)	2.1–8.4 kW	2.1–8.4 kW
Fan motor type	3-step AC	3-step AC
Drain Pump	Optional	Optional
Filter	Polypropylene washable	Polypropylene washable
3-Way Valve	Built-in	Built-in
2-pipe	●	●
4-pipe (optional)	●	●
Installation	Horizontal/vertical	Horizontal/vertical

¹ Concealed FCU and Cased FCU are third party products

Nomenclature

Indoor units

AG	072	A	N	4	P	K	H
1	2	3	4	5	6	7	8

1	Classification	AG	Chiller/Fan Coil Unit (FCU)
2	Capacity	x1/10 kW (3 digits)	
3	Version	K	2016
		M	2017
		N	2018
		T	2020
		A	2021
4	Product Type	N	Indoor Unit
5	Product Notation	1	WindFree™ 1-Way Cassette
		4	WindFree™ 4-Way Cassette, 360 Cassette
6	Feature	D	Deluxe
		P	Premium
7	Voltage Rating	K	1Φ, 220~240 V, 50/60 Hz
8	Mode	H	Heat Pump

Indoor units (third party)

ACL	65	D	F
1	2	3	4

1	Classification	ACL	Chiller/Fan Coil Unit (FCU)
2	Capacity	x1/10 kW (3 digits)	
3	Product Notation	D	2-Pipe FCU
		Q	4-Pipe FCU
		A	Accessory
4	Product Type	F	Concealed
		G	Cased

Outdoor units

AG	070	K	S	V	A	N	H
1	2	3	4	5	6	7	8

1	Classification	AG	Chiller (HVM Chiller)
2	Capacity	kW (3 digits)	
3	Version	K	2016
		M	2017
		N	2018
4	Product Type	S	SETHVM Chiller
5	Product Notation	V	Inverter
6	Feature	A	Non-pump
7	Voltage Rating	N	3Φ, 380-415 V, 50/60 Hz
8	Mode	H	Heat Pump

HVM Chiller



Modular Function

HVM Chiller heat pump outdoor units are available in three different sizes: 42/56/65 kW. A maximum of 16 outdoor units can be connected to achieve a maximum capacity of 1,040 kW. By connecting multiple units within a single system, the workload is adjusted automatically

for maximum efficiency. The HVM system's water-based concept eliminates the need for refrigerant inside the building, making it safer than traditional VRF systems. Its refrigerant charge is up to 65 % lower¹ than in traditional VRF systems.

¹ Compared to a Samsung DVM S 60 HP, holding R410A refrigerant, connected to twelve 14 kW indoor units and 100 metres of pipes.

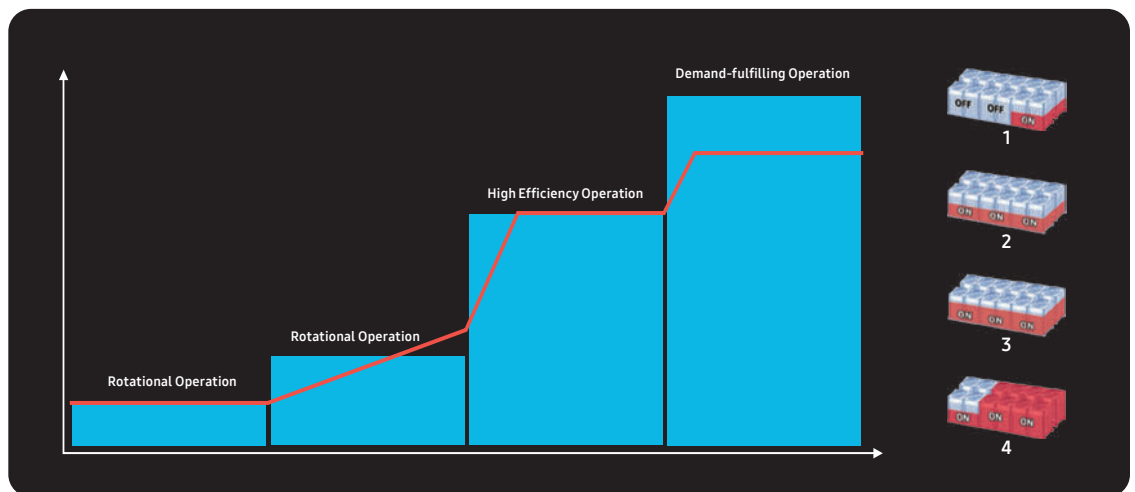

1. At low load, the varying outdoor units are switched on at alternate intervals
- 2/3. At average load, the outdoor units are operated at partial load to optimise efficiency
4. At maximum load, all compressors of all outdoor units are operated at maximum capacity

Local and centralised controls

The DVM Chiller utilises the same integrated control systems as a VRF system, and can be connected to a third-party Building Management System (BMS). With the use of the Fan Coil Unit (FCU) kit, third-party indoor units and control systems can also be connected. The Samsung DMS 2.5 makes control and maintenance easy.

System control

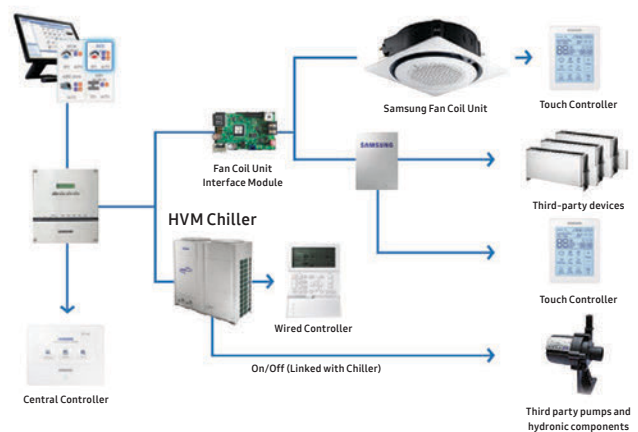



WindFree™ 1&4-Way Cassette

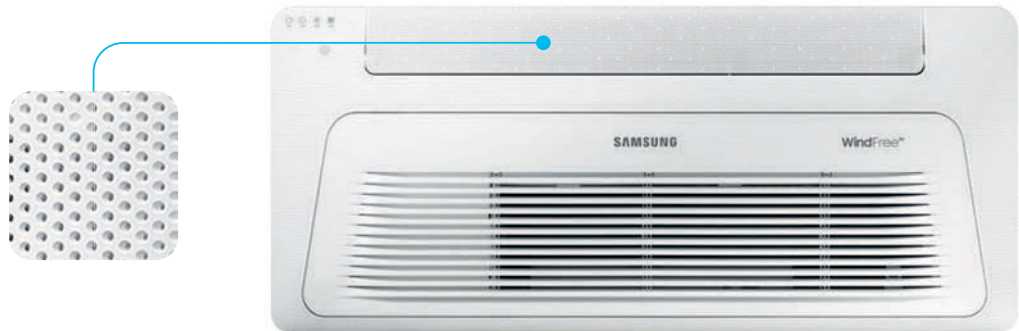

WindFree™ Technology

The WindFree™ Cassette¹ directs air through thousands of micro-holes in the panel. These micro-holes are essential for creating a type of airflow called “Still Air”² which cools the room gradually and noticeably without drafts.

¹ WindFree™ 1-Way Cassette uses 13,000 microholes, WindFree™ 4-Way Cassette uses 15,700 microholes, WindFree™ 4-Way 600 x 600 Cassette uses 9,000 microholes.

² ASHRAE (American Society of Heating, Refrigeration, and Air-Conditioning Engineers) defines “Still Air” as air currents at speeds below 0.15 m/s which lack the presence of cold drafts.

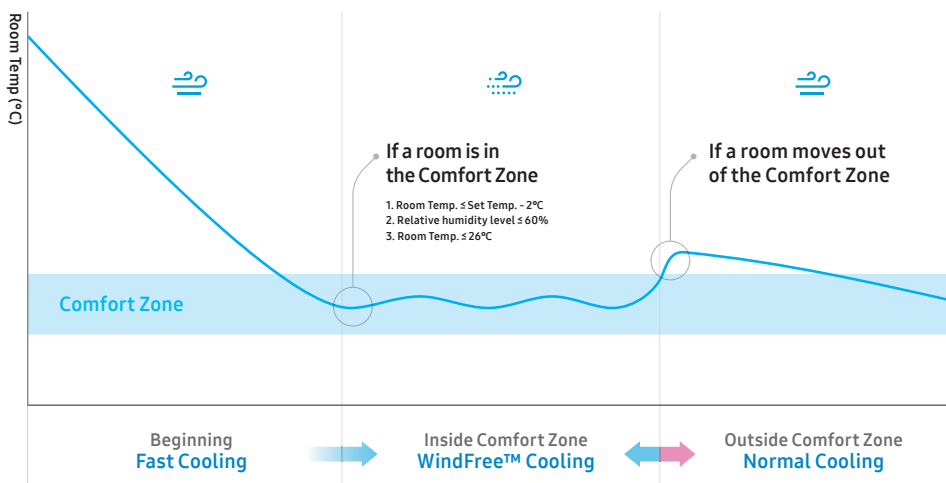

Smart Comfort Operation

The Fast Cooling process helps to achieve the desired temperature in a room quickly. By simultaneously detecting the humidity¹ levels, the Smart Comfort Operation feature maintains the room's temperature automatically.

¹ The humidity level will only be shown during WindFree™ operation and Dry Mode via the SmartThings app display.

Slim installation

At a height of only 135 mm¹, the WindFree™ 1-Way Cassette is a compact and lightweight device (8–13.5 kg). This slim design makes it not only visually pleasing but also easier to install and maintain, and it can be fitted into small gaps or ceilings.

¹ 135 mm is the height of the unit until the ceiling tile. 145 mm is the height including the ceiling tile. Up to 3.6 kW (DVM) models measures 135 mm (180 mm including panel).

Optimised blades

The larger optimised blade(s) of the 1- and 4-Way facilitate a wider cooling range and improved air circulation within the room. This advanced technology also cools the space much faster leaving no zone untouched. The blades of the 4-Way cassette are detachable and can be washed easily with water to remove dust or debris that has collected on them, therefore allowing for optimal quality of airflow that in turn helps maintain a cleaner environment.

¹ 100 mm WindFree™ 1-Way Cassette, 84 mm WindFree™ 4-Way Cassette, 66 mm WindFree™ 4-Way 600 x 600 Cassette. Samsung testing compares the WindFree™ 1-Way Cassette to a conventional 1-Way Cassette-type air conditioner. And the WindFree™ 4-Way and WindFree™ 4-Way 600 x 600 Cassette to a previous 4-Way Cassette type air conditioner.

² Based on the 7.1 kW indoor unit.

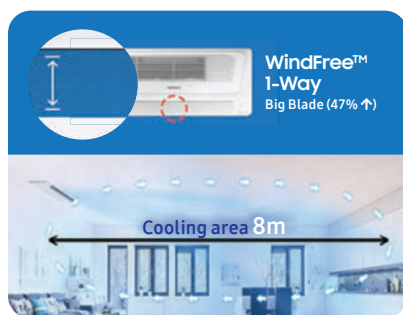

360 cassette

Circular LED display

The unit features a stylish panel and an intuitive Circular LED display, which allows users to choose or adjust the direction of the airflow with an intuitive wireless (jog shuttle) wireless remote controller. Besides the LED Display also monitors other essential operating information, such as the filter the air flow direction, filter status and any errors. So, with just one glance, you can quickly tell where the air is going and how your 360 Cassette is performing.



Airflow Control

The air supply is easily adjusted without the use of flaps. Three booster fans work to alter the direction of airflow from within the cassette's hollow space. A rain-like distribution of the air (known as the 'coanda' effect) keeps the room cool and comfortable at all times. The innovative technology overcomes the usual limits of the conventional outlets that use blades, as they obstruct the air at low angles and cause a significant low airflow¹. The Motion Detector Sensor (MDS) is available for the 360 Cassette.

¹ Based on internal testing compared to a general 4-Way Cassette air conditioner.

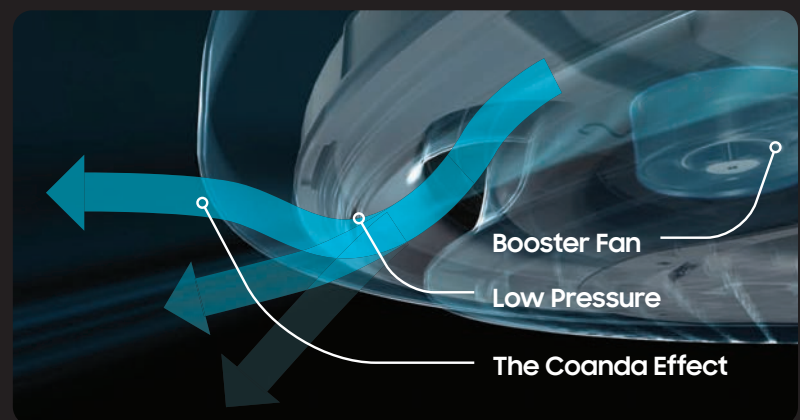

For more product features, refer to the following pages:

WindFree™ 4-Way cassette: pages 84-93

WindFree™ 1-Way Cassette: pages 94-99

360 Cassette: pages 100-107

Specifications

HVM Chiller



- Option of connecting up to 16 modules for a total capacity of more than 1 MW.
- Air-cooled HVM Chiller Heat Pump.
- Capacity modulation between 15% and 100%.
- Each unit houses 2 Inverter Scroll compressors, all equipped with Flash Injection technology.



Model			AG042KSVANH/EU	AG056KSVANH/EU	AG070KSVANH/EU
Power Supply			Φ, #, V, Hz		
			3Φ, 4, 380-415 V, 50/60 Hz	3Φ, 4, 380-415 V, 50/60 Hz	3Φ, 4, 380-415 V, 50/60 Hz
Performance					
Capacity (Nominal)	Cooling	kW	42	56	65
	Heating	kW	42.0	56.0	69.5
Power					
Power Input (Nominal)	Cooling	kW	12.35	18.67	26.00
	Heating	kW	11.83	17.50	24.39
Current Input (Nominal)	Cooling	A	19.6	29.6	41.2
	Heating	A	18.8	27.8	38.7
Current	MCA	A	32	46	58
	MFA	A	40	60	75
Efficiency					
ESEER (Pump input is not included)	W/W		5.7	5.4	5.0
Fan					
Type	-		Axial Fan	Axial Fan	Axial Fan
Number of Fans	-		2	2	2
Airflow Rate	m ³ /min		364 (182 x 2)	364 (182 x 2)	392 (196 x 2)
	U/s		6,067	6,067	6,535
External Static Pressure	Max.	mmAq	8.00	8.00	8.00
		Pa	78.5	78.5	78.5
Fan Motor					
Type	-		BLDC Motor	BLDC Motor	BLDC Motor
Output x n	W		630 x 2	630 x 2	630 x 2
Water Side Heat Exchanger					
Type	-		Brazing Plate	Brazing Plate	Brazing Plate
Water Flow Rate (Cooling/Heating)	L/min		120/120	160/160	186/200
Pressure Drop (Set. Nominal)	kPa		60	100	120
Max. Operating Pressure	MPa		1	1	1
Connection Type	-		FLANGE	FLANGE	FLANGE
Pipe Connection (Inlet/Outlet)	Ø, mm		40	40	50
	Ø, inch		1 1/2	1 1/2	2
Quantity	-		2	2	2
Wiring Connections					
Communication	Min.	mm ²	0.75	0.75	0.75
	Remark		F1, F2	F1, F2	F1, F2
Refrigerant					
Type	-		R410A (Fluorinated greenhouse gas, GWP=2,088)		
Factory Charging	kg/tCO ₂ e		18/37.58	18/37.58	18/37.58
Sound					
Sound Pressure	Cooling	dB(A)	60	62	63
	Heating	dB(A)	57	59	64
Sound Power	dB(A)		80	83	85
External Dimensions					
Net Weight	kg		446.0	446.0	465.0
Net Dimensions (W x H x D)	mm		1,795 x 1,695 x 765	1,795 x 1,695 x 765	1,795 x 1,695 x 765
Operating Water Temperature Range					
Cooling	°C		5.0-25.0	5.0-25.0	5.0-25.0
Cooling (if using brine)	°C		-10.0-25.0	-10.0-25.0	-10.0-25.0
Heating	°C		25.0-55.0	25.0-55.0	25.0-55.0
Operating Water Flow Range					
Water Flow Rate	L/min		60-240	80-320	93-400
Minimum Water Storage in the System	L		294	392	490
Operating Ambient Temperature Range					
Cooling	°C		-15.0-48.0	-15.0-48.0	-15.0-48.0
Heating	°C		-25.0-43.0	-25.0-43.0	-25.0-43.0

Accessories



Module Controller	DMS2.5	BACnet Gateway	Touch Centralised Controller	On/Off controller	PIM Module (Pulse Interface Module)	LonWorks Gateway	External Contact Interface Module
MCM-A00N	MIM-D01AN	MIM-B17BN	MCM-A300N	MCM-A202DN	MIM-B16N	MIM-B18BN	MIM-B14



Specifications

WindFree™ 1-Way Cassette FCU UNIQUE

- One-Way air supply by means of a 100 mm wide blade.
- Cross-flow fan direct driven by a BLDC motor.
- Built-in condensation drain pump.
- Optional 3-Way valve kit.
- Available in WindFree™ function.
- Can be controlled by Smartphone via Wi-Fi Kit.



Model			AG026TN1DKH/EU	AG032TN1DKH/EU	AG042TN1DKH/EU
Power Supply			Φ, V, Hz		
			1Φ, 220-240 V, 50/60 Hz	1Φ, 220-240 V, 50/60 Hz	1Φ, 220-240 V, 50/60 Hz
Mode			HP		
Performance					
Capacity (Nominal)	Cooling	kW	2.60	3.00	4.20
	Heating	kW	2.90	3.40	5.00
Power					
Power Input (Nominal)	Cooling	W	27	35	55
	Heating	W	27	35	55
Current Input (Nominal)	Cooling	A	0.14	0.19	0.29
	Heating	A	0.14	0.19	0.29
Heat Exchanger					
Type			Fin & tube	Fin & tube	Fin & tube
Fan					
Type			Crossflow fan	Crossflow fan	Crossflow fan
Number of Fans			1	1	1
Airflow Rate	H/M/L	m ³ /min	6.8/5.8/4.9	7.8/6.8/5.8	14.6/12.6/10.7
Fan Motor					
Type			BLDC	BLDC	BLDC
Output x n			27 x 1	27 x 1	65 x 1
Water					
Water Flow Rate	Cooling	L/min	7.5	9.6	11.9
Water Flow Rate	Heating	L/min	8.4	9.7	14.4
Pressure Drop	Cooling	kPa	23.0	34.5	45.0
Pressure Drop	Heating	kPa	28.0	35.8	64.6
Piping Connections					
Liquid Pipe (IN)	Type		PF MALE	PF MALE	PF MALE
	Ø, mm (inch)		20A (3/4")	20A (3/4")	20A (3/4")
Liquid Pipe (OUT)	Type		PF MALE	PF MALE	PF MALE
	Ø, mm (inch)		20A (3/4")	20A (3/4")	20A (3/4")
Heat Insulation			Both inlet/outlet pipes	Both inlet/outlet pipes	Both inlet/outlet pipes
Drain Pipe	Ø, mm		VP20 (OD 26, ID 20)	VP20 (OD 26, ID 20)	VP25 (OD 32, ID 25)
Sound					
Sound Pressure ¹	(H/M/L)	dB(A)	33/31/29	38/35/31	40/37/33
Sound Power	Cooling	dB(A)	50	53	59
Dimensions					
Net Weight			10.1	10.1	14.0
Net Dimensions (W × H × D)			970 × 135 × 410	970 × 135 × 410	1,200 × 138 × 450
Casing			Plastic	Plastic	Plastic
Material			Plastic	Plastic	Plastic
Panel					
Panel Model			PC1NWFMBN(WindFree™)	PC1NWFMBN(WindFree™)	PC1BWFMBN(WindFree™)
Additional Accessories					
Drain Pump	Type		Built-in	Built-in	Built-in
	Max. Lifting Height/ Displacement	mm/(cc/min)	750/400	750/400	750/400
3-Way Valve Kit (optional)			ACL-A60V3	ACL-A60V3	ACL-A60V3
Filter			-	-	-

Accessories



Panel WindFree™ (optional)	Panel WindFree™ (optional)	FCU Interface Module	Wireless Remote Controller	Simple Type Controller	Touch Controller	Wired Remote Controller
PC1NWFMBN	PC1BWFMBN	MIM-F10N	AR-EH03E, AR-CH01E	MWR-SH00N	MWR-SH11N	MWR-WG00*N

Cooling: Indoor temperature 27°C DB, 19°C WB/Water In/Out temperature 7°C, 12°C Heating: Indoor temperature 20°C DB, 15°C WB/Water In/Out temperature 45°C, 40°C.
 Sound level was acquired in an anechoic room. Thus actual noise level may be different depending on the installation conditions.
 Specifications may be subject to change without prior notice.
 Select wire size based on the Minimum Circuit Ampacity (MCA) value.

Specifications

WindFree™ 4-Way Cassette FCU UNIQUE

- Four-Way air supply via independently adjustable blades.
- Direct drive fan powered by a BLDC motor.
- Built-in condensation drain pump.
- Optional 3-Way valve kit.
- Can be controlled by Smartphone via Wi-Fi Kit.
- Available in WindFree™ function.



			AG060AN4DKH/EU	AG072AN4DKH/EU	AG090AN4DKH/EU	AG105AN4DKH/EU	
Power Supply		Φ, V, Hz	1Φ, 220-240 V, 50/60 Hz	1Φ, 220-240 V, 50/60 Hz	1Φ, 220-240 V, 50/60 Hz	1Φ, 220-240 V, 50/60 Hz	
Mode			HP	HP	HP	HP	
Performance							
Capacity (Nominal)	Cooling	kW	6.0	7.2	9.0	10.0	
	Heating	kW	7.3	8.5	10.0	10.7	
Power							
Power Input (Nominal)	Cooling	W	50	73	82	99	
	Heating	W	50	73	82	99	
Current Input (Nominal)	Cooling	A	0.37	0.50	0.58	0.79	
	Heating	A	0.37	0.50	0.58	0.79	
Heat Exchanger							
Type		-	Fin & tube	Fin & tube	Fin & tube	Fin & tube	
Fan							
Type		-	Turbo Fan	Turbo Fan	Turbo Fan	Turbo Fan	
Number of Fans		-	1	1	1	1	
Airflow Rate		H/M/L	18.9/16.5/13.6	21.3/18.2/13.6	23.3/21.3/19.4	30.1/26.2/19.4	
Fan Motor							
Type		-	BLDC	BLDC	BLDC	BLDC	
Output x n		W	65 x 1	65 x 1	97 x 1	97 x 1	
Water							
Water Flow Rate		Cooling	L/min	17.5	20.8	26.0	28.9
Water Flow Rate		Heating	L/min	21.1	24.5	28.9	30.9
Pressure Drop		Cooling	kPa	27.0	36.0	46.8	56.3
Pressure Drop		Heating	kPa	37.3	48.6	56.3	63.4
Piping Connections							
Liquid Pipe (IN)		Type	PF MALE	PF MALE	PF MALE	PF MALE	
		Ø, mm (inch)	20A (3/4)	20A (3/4)	20A (3/4)	20A (3/4)	
Liquid Pipe (OUT)		Type	PF MALE	PF MALE	PF MALE	PF MALE	
		Ø, mm (inch)	20A (3/4)	20A (3/4)	20A (3/4)	20A (3/4)	
Heat Insulation		-	Both inlet/outlet pipes	Both inlet/outlet pipes	Both inlet/outlet pipes	Both inlet/outlet pipes	
Drain Pipe		Ø, mm	VP25 (OD 32, ID 25)	VP25 (OD 32, ID 25)	VP25 (OD 32, ID 25)	VP25 (OD 32, ID 25)	
Sound							
Sound Pressure		(H/M/L)	dB(A)	37/33/30	41/36/30	42/39/36	45/41/37
Sound Power		Cooling	dB(A)	56	60	58	60
Dimensions							
Net Weight		kg	15.5	15.5	18.0	18.0	
Net Dimensions (W × H × D)		mm	840 × 204 × 840	840 × 204 × 840	840 × 246 × 840	840 × 246 × 840	
Panel							
Panel Model		-	PC4NUFMAN	PC4NUFMAN	PPC4NUFMAN	PC4NUFMAN	
Additional Accessories							
Drain Pump		Type	-	Built-in	Built-in	Built-in	Built-in
		Max. Lifting Height/ Displacement	mm/(cc/min)	750/400	750/400	750/400	750/400
3-Way Valve Kit (optional)			ACL-A60V3	ACL-A60V3	ACL-A60V3	ACL-A60V3	
Filter		-	Microfibrous filter	Microfibrous filter	Microfibrous filter	Microfibrous filter	

Accessories



Panel WindFree™	FCU Interface Module	Wireless Remote Controller	Simple Type Controller	Touch Controller	Wired Remote Controller
PC4NUFMAN	MIM-F10N	AR-EH03E, AR-CH01E	MWR-SH00N	MWR-SH11N	MWR-WG00*N

Cooling: Indoor temperature 27°C DB, 19°C WB/Water In/Out temperature 7°C, 12°C Heating: Indoor temperature 20°C DB, 15°C WB/Water In/Out temperature 45°C, 40°C.
 Sound level was acquired in an anechoic room. Thus actual noise level may be different depending on the installation conditions.
 Specifications may be subject to change without prior notice.
 Select wire size based on the Minimum Circuit Ampacity (MCA) value.

Specifications

360 Cassette FCU

- 360 degree air supply.
- Bladeless discharge. Booster fans can be individually controlled, allowing for completely horizontal flow discharge. Coandă effect is created even without ceiling.
- 3-Way valve kit (optional).
- Can be controlled by Smartphone via Wi-Fi Kit.
- A front panel is mandatory and can be selected from one of the 4 front panels mentioned in the accessories.
- Built-in condensation drain pump.
- Predisposition of the air inlet to let fresh air in.
- Circular or square cassette panel.
- Optional Motion Detect Sensor.













Model			AG060MN4PKH/EU	AG072MN4PKH/EU	AG090MN4PKH/EU	AG105MN4PKH/EU	
Power Supply		Φ, V, Hz	1Φ, 220-240 V, 50/60 Hz	1Φ, 220-240 V, 50/60 Hz	1Φ, 220-240 V, 50/60 Hz	1Φ, 220-240 V, 50/60 Hz	
Mode			HP	HP	HP	HP	
Performance							
Capacity (Nominal)		Cooling	kW	6.0	7.2	9.0	10.0
		Heating	kW	7.3	8.5	10.0	10.7
Power							
Power Input (Nominal)		Cooling	W	58	58	77	100
		Heating	W	58	58	77	100
Current Input (Nominal)		Cooling	A	0.50	0.50	0.62	0.79
		Heating	A	0.50	0.50	0.62	0.79
Heat Exchanger							
Type		-	Fin & tube	Fin & tube	Fin & tube	Fin & tube	
Fan							
Type		-	Turbo Fan	Turbo Fan	Turbo Fan	Turbo Fan	
Number of Fans		ea	1	1	1	1	
Airflow Rate		H/M/L	m ³ /min	21.0/17.5/15.0	25.5/22.0/19.8	29.5/24.0/19.8	31.5/22.5/19.8
Fan Motor							
Type		-	BLDC	BLDC	BLDC	BLDC	
Output x n		W	65 x 1	97 x 1	97 x 1	97 x 1	
Water							
Water Flow Rate		Cooling	L/min	17.5	20.8	26.0	28.9
		Heating	L/min	21.1	24.5	28.9	30.9
Pressure Drop		Cooling	kPa	27.0	26.0	38.5	47.4
		Heating	kPa	37.6	35.6	47.4	53.2
Piping Connections							
Liquid Pipe (IN)		Type	PF MALE	PF MALE	PF MALE	PF MALE	
		Ø, mm (inch)	20A (3/4)	20A (3/4)	20A (3/4)	20A (3/4)	
Liquid Pipe (OUT)		Type	PF MALE	PF MALE	PF MALE	PF MALE	
		Ø, mm (inch)	20A (3/4)	20A (3/4)	20A (3/4)	20A (3/4)	
Heat Insulation		-	Both inlet/outlet pipes	Both inlet/outlet pipes	Both inlet/outlet pipes	Both inlet/outlet pipes	
Drain Pipe		Ø, mm	VP25 (OD 32, ID 25)	VP25 (OD 32, ID 25)	VP25 (OD 32, ID 25)	VP25 (OD 32, ID 25)	
Sound							
Sound Pressure		(H/M/L)	dB(A)	40/37/32	39/35/33	43/38/33	45/39/33
Sound Power		Cooling	dB(A)	57	58	60	62
Dimensions							
Net Weight		kg	21.0	25.0	25.0	25.0	
Net Dimensions (W × H × D)		mm	947 x 281 x 947	947 x 365 x 947	947 x 365 x 947	947 x 365 x 947	
Casing							
Material		-	-	-	-	-	
Panel							
Panel Model		White	PC4NUDMAN	PC4NUNMAN	PC4NUNMAN	PC4NUNMAN	
			PC4NUNMAN	PC4NUNMAN	PC4NUNMAN	PC4NUNMAN	
		Black	PC4NBDMAN	PC4NBDMAN	PC4NBDMAN	PC4NBDMAN	
			PC4NBNMAN	PC4NBNMAN	PC4NBNMAN	PC4NBNMAN	
Additional Accessories							
Drain Pump		Type	-	Built-in	Built-in	Built-in	
		Max. Lifting Height/ Displacement	mm/(cc/min)	750/400	750/400	750/400	
		3-Way Valve Kit	(optional)	ACL-A60V3	ACL-A60V3	ACL-A60V3	
Filter		-	Microfibrous filter	Microfibrous filter	Microfibrous filter	Microfibrous filter	

Cooling: Indoor temperature 27°C DB, 19°C WB/Water In/Out temperature 7°C, 12°C Heating: Indoor temperature 20°C DB, 15°C WB/Water In/Out temperature 45°C, 40°C.
 Sound level was acquired in an anechoic room. Thus actual noise level may be different depending on the installation conditions.
 Specifications may be subject to change without prior notice.
 Select wire size based on the Minimum Circuit Ampacity (MCA) value.



Accessories

									
Panel (Mandatory)	Panel (Mandatory)	Panel (Mandatory)	Panel (Mandatory)	FCU Interface Module	Wireless Remote Controller	Touch Controller	Wired Remote Controller	Simple Type Controller	Motion Detect Sensor (Optional)
PC4NBDMAN	PC4NBNMAN	PC4NUDMAN	PC4NUNMAN	MIM-F10N	AR-EH03E, AR-CH01E	MWR-SH11N	MWR-WG00*N	MWR-SH00N	MCR-SME

Specifications

Concealed FCU

- Plug & play solution in combination with HVM Chiller.
- Optional vertical or horizontal installation.
- 3-Way valve kit included as standard.
- FCU kit included as standard.
- Optional drain pipe.
- Optional heating coil 4-pipe.
- Optional 3-Way valve kit 4-pipe.
- Auxiliary Drain Pan vertical/horizontal.



Model			ACL-18DF	ACL-25DF	ACL-35DF	
Power Supply		Φ , V, Hz	1 Φ , 220-240 V, 50/60 Hz	1 Φ , 220-240 V, 50/60 Hz	1 Φ , 220-240 V, 50/60 Hz	
Mode			HP	HP	HP	
Performance						
Capacity (Nominal)	Cooling (H/M/L)	kW	1.91/1.66/1.34	2.87/2.34/1.73	4.24/3.20/2.47	
	Heating (H/M/L)	kW	2.15/1.81/1.50	2.91/2.35/1.73	4.24/3.24/2.47	
Power						
Power Input (Nominal)	Cooling (H/M/L)	W	53/36/24	56/43/29	90/50/40	
	Heating (H/M/L)	W	53/36/24	56/43/29	90/50/40	
Current Input (Nominal)	Cooling	A	0.26	0.28	0.45	
	Heating	A	0.26	0.28	0.45	
Heat Exchanger						
Type		-	Fin & tube	Fin & tube	Fin & tube	
Fan						
Type		-	Double suction centrifugal fan	Double suction centrifugal fan	Double suction centrifugal fan	
Number of Fans		ea	2	2	2	
Airflow Rate		H/M/L	m³/min			
			5.7/4.5/3.5	7.6/5.7/4.0	11.7/8.3/6.0	
Fan Motor						
Type		-	3-step AC	3-step AC	3-step AC	
Output x n		W	53/36/24	56/43/29	90/50/40	
Water						
Water Flow Rate	Cooling	L/min	5.6	8.4	12.4	
	Heating	L/min	6.2	8.4	12.4	
Pressure Drop	Cooling	kPa	17	24	35	
	Heating	kPa	20	24	35	
Piping Connections						
Liquid Pipe (IN)	Type	-	Female	Female	Female	
	Dimension	Φ, mm (inch)	1/2	1/2	1/2	
Liquid Pipe (OUT)	Type	-	Female	Female	Female	
	Dimension	Φ, mm (inch)	1/2	1/2	1/2	
Heat Insulation		-	-	-	-	
Drain Pipe		Φ, mm	-	-	-	
Sound						
Sound Pressure		(H/M/L)	dB(A)	42/36/32	40/34/28	45/35/27
Sound Power		(H/M/L)	dB(A)	50/44/40	48/42/36	53/43/35
Dimensions						
Net Weight		kg	18.0	23.0	27.0	
Net Dimensions (W x H x D)		mm	725 x 224 x 535	935 x 224 x 535	1,145 x 224 x 535	
Casing						
Material		-	-	-	-	
Panel						
Panel Model		-	-	-	-	
Additional Accessories						
Drain Pump	Type	optional	ACL-ADP	ACL-ADP	ACL-ADP	
	Max. Lifting Height/Displacement	mm/(cc/min)	750/133	750/133	750/133	
Heating Coil	4-pipe	optional	ACL-A018HC	ACL-A025HC	ACL-A035HC	
3-Way Valve	4-pipe	optional	ACL-A018V3	ACL-A018V3	ACL-A018V3	
Auxiliary Drain Pan	Vertical	optional	ACL-ADV	ACL-ADV	ACL-ADV	
	Horizontal	optional	ACL-ADH	ACL-ADH	ACL-ADH	
Filter		-	Polypropylene washable	Polypropylene washable	Polypropylene washable	

Cooling: Indoor temperature 27°C DB, 19°C WB/Water In/Out temperature 7°C, 12°C Heating: Indoor temperature 20°C DB, 15°C WB/Water In/Out temperature 45°C, 40°C. Sound level was acquired in an anechoic room. Thus actual noise level may be different depending on the installation conditions. Specifications may be subject to change without prior notice. Select wire size based on the Minimum Circuit Ampacity (MCA) value.



ACL-55DF	ACL-65DF
1Φ, 220-240 V, 50/60 Hz HP	1Φ, 220-240 V, 50/60 Hz HP
719/5.69/4.32	778/6.07/4.00
719/5.69/4.32	8.37/6.53/4.39
182/127/86	244/169/109
182/127/86	244/169/109
0.90	1.20
0.90	1.20
Fin & tube	Fin & tube
Double suction centrifugal fan 3	Double suction centrifugal fan 3
16.8/12.8/9.5	23.2/17.0/10.7
3-step AC 182/127/86	3-step AC 244/169/109
21.1	22.9
20.2	24.2
39	42
35	47
Female 3/4	Female 3/4
Female 3/4	Female 3/4
-	-
-	-
53/46/39	59/52/41
61/54/47	67/60/49
370	370
1,355 x 249 x 535	1,355 x 249 x 535
-	-
-	-
ACL-ADP	ACL-ADP
750/133	750/133
ACL-A055HC	ACL-A055HC
ACL-A055V3	ACL-A055V3
ACL-ADV	ACL-ADV
ACL-ADH	ACL-ADH
Polypropylene washable	Polypropylene washable

Accessories



FCU Interface Module	FCU Kit	Touch Controller
----------------------	---------	------------------

MIM-F10N

MIM-F00N

MWR-SH11N



Wired Remote Controller	Simple Type Controller
-------------------------	------------------------

MWR-WG00*N

MWR-SH00N

Specifications

Cased FCU

- Plug & play solution in combination with HVM Chiller.
- Optional vertical or horizontal installation.
- 3-Way valve kit included as standard.
- FCU kit included as standard.
- Optional drain pipe.
- Optional heating coil 4-pipe.
- Optional 3-Way valve kit 4-pipe.
- Auxiliary Drain Pan vertical/horizontal.



Model			ACL-18DG	ACL-25DG	ACL-35DG
Power Supply		Φ , V, Hz	1 Φ , 220-240 V, 50/60 Hz	1 Φ , 220-240 V, 50/60 Hz	1 Φ , 220-240 V, 50/60 Hz
Mode			HP	HP	HP
Performance					
Capacity (Nominal)	Cooling (H/M/L)	kW	1.91/1.66/1.34	2.87/2.34/1.73	4.24/3.20/2.47
	Heating (H/M/L)	kW	2.15/1.81/1.50	2.91/2.35/1.73	4.24/3.24/2.47
Power					
Power Input (Nominal)	Cooling (H/M/L)	W	53/36/24	56/43/29	90/50/40
	Heating (H/M/L)	W	53/36/24	56/43/29	90/50/40
Current Input (Nominal)	Cooling	A	0.26	0.28	0.45
	Heating	A	0.26	0.28	0.45
Heat Exchanger					
Type		-	Fin & tube	Fin & tube	Fin & tube
Fan					
Type		-	Double suction centrifugal fan	Double suction centrifugal fan	Double suction centrifugal fan
Number of Fans		-	2	2	2
Airflow Rate	H/M/L	m³/min	5.7/4.5/3.5	7.6/5.7/4.0	11.7/8.3/6.0
Fan Motor					
Type		-	3-step AC	3-step AC	3-step AC
Output x n		W	53/36/24	56/43/29	90/50/40
Water					
Water Flow Rate	Cooling	l/min	5.6	8.4	12.4
	Heating	l/min	6.2	8.4	12.4
Pressure Drop	Cooling	kPa	17	24	35
	Heating	kPa	20	24	35
Piping Connections					
Liquid Pipe (IN)	Type	-	Female	Female	Female
	Dimension	\emptyset, mm (inch)	1/2	1/2	1/2
Liquid Pipe (OUT)	Type	-	Female	Female	Female
	Dimension	\emptyset, mm (inch)	1/2	1/2	1/2
Heat Insulation		-	-	-	-
Drain Pipe		\emptyset, mm	-	-	-
Sound					
Sound Pressure	(H/M/L)	dB(A)	42/36/32	40/34/28	45/35/27
Sound Power	(H/M/L)	dB(A)	50/44/40	48/42/36	53/43/35
Dimensions					
Net Weight		kg	22.0	29.0	35.0
Net Dimensions (W x H x D)		mm	774x564x226	984x564x226	1,194x564x226
Casing					
Material		-	-	-	-
Panel					
Panel Model		-	-	-	-
Additional Accessories					
Drain Pump	Type	optional	ACL-ADP	ACL-ADP	ACL-ADP
	Max. Lifting Height/Displacement	mm / (cc/min)	750/133	750/133	750/133
Heating Coil	4-pipe	optional	ACL-A018HC	ACL-A025HC	ACL-A035HC
3-Way Valve	4-pipe	optional	ACL-A018V3	ACL-A018V3	ACL-A018V3
Auxiliary Drain Pan	Vertical	optional	ACL-ADV	ACL-ADV	ACL-ADV
Auxiliary Drain Pan	Horizontal	optional	ACL-ADH	ACL-ADH	ACL-ADH
Filter		-	Polypropylene washable	Polypropylene washable	Polypropylene washable

Cooling: Indoor temperature 27°C DB, 19°C WB/Water In/Out temperature 7°C, 12°C Heating: Indoor temperature 20°C DB, 15°C WB/Water In/Out temperature 45°C, 40°C.
 Sound level was acquired in an anechoic room. Thus actual noise level may be different depending on the installation conditions.
 Specifications may be subject to change without prior notice.
 Select wire size based on the Minimum Circuit Ampacity (MCA) value.



ACL-55DG	ACL-65DG
1Φ, 220~240 V, 50/60 Hz HP	1Φ, 220~240 V, 50/60 Hz HP
719/5.69/4.32	778/6.07/4.00
719/5.69/4.32	8.37/6.53/4.39
182/127/86	244/169/109
182/127/86	244/169/109
0.90	1.20
0.90	1.20
Fin & tube	Fin & tube
Double suction centrifugal fan 3	Double suction centrifugal fan 3
16.8/12.8/9.5	23.2/17.0/10.7
3-step AC	3-step AC
182/127/86	244/169/109
21.1	22.9
20.2	24.2
39	42
35	47
Female 3/4	Female 3/4
Female 3/4	Female 3/4
-	-
-	-
53/46/39	59/52/41
61/54/47	67/60/49
45.0	45.0
1,404x564x251	1,404x564x251
-	-
-	-
ACL-ADP	ACL-ADP
750/133	750/133
ACL-A055HC	ACL-A055HC
ACL-A055V3	ACL-A055V3
ACL-ADV	ACL-ADV
ACL-ADH	ACL-ADH
Polypropylene washable	Polypropylene washable

Accessories



FCU Interface Module	FCU Kit	Touch Controller
----------------------	---------	------------------

MIM-F10N

MIM-F00N

MWR-SH11N



Wired Remote Controller	Simple Type Controller
-------------------------	------------------------

MWR-WG00*N

MWR-SH00N

Dimensional drawings

HVM Chiller

AG042/056/070KSVANH/EU

Units: mm [inches]

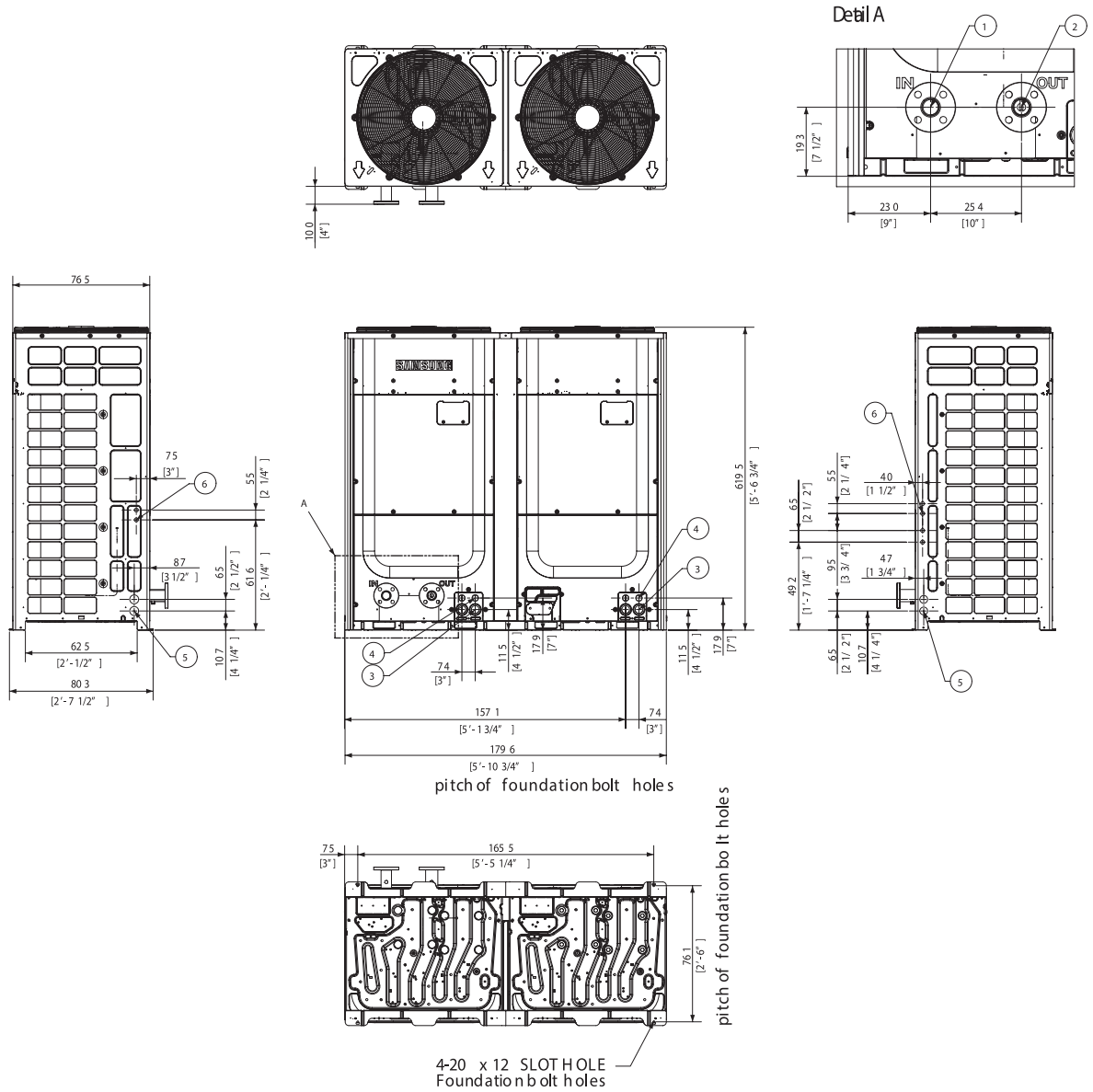

NO	Name	Description
1	Inlet water flange	15/20 HP: 40A Din Flange, 25 HP: 50A Din Flange
2	Outlet water flange	15/20 HP: 40A Din Flange, 25 HP: 50A Din Flange
3	Power wiring conduits	Knock-out hole (front)
4	Communication wiring conduits	Knock-out hole (front)
5	Power wiring conduits	Knock-out hole (side)
6	Communication wiring conduits	Knock-out hole (side)



Dimensional drawings

WindFree™ 1-Way Cassette FCU

AG026/032TN1DKH/EU

Units: mm [inches]

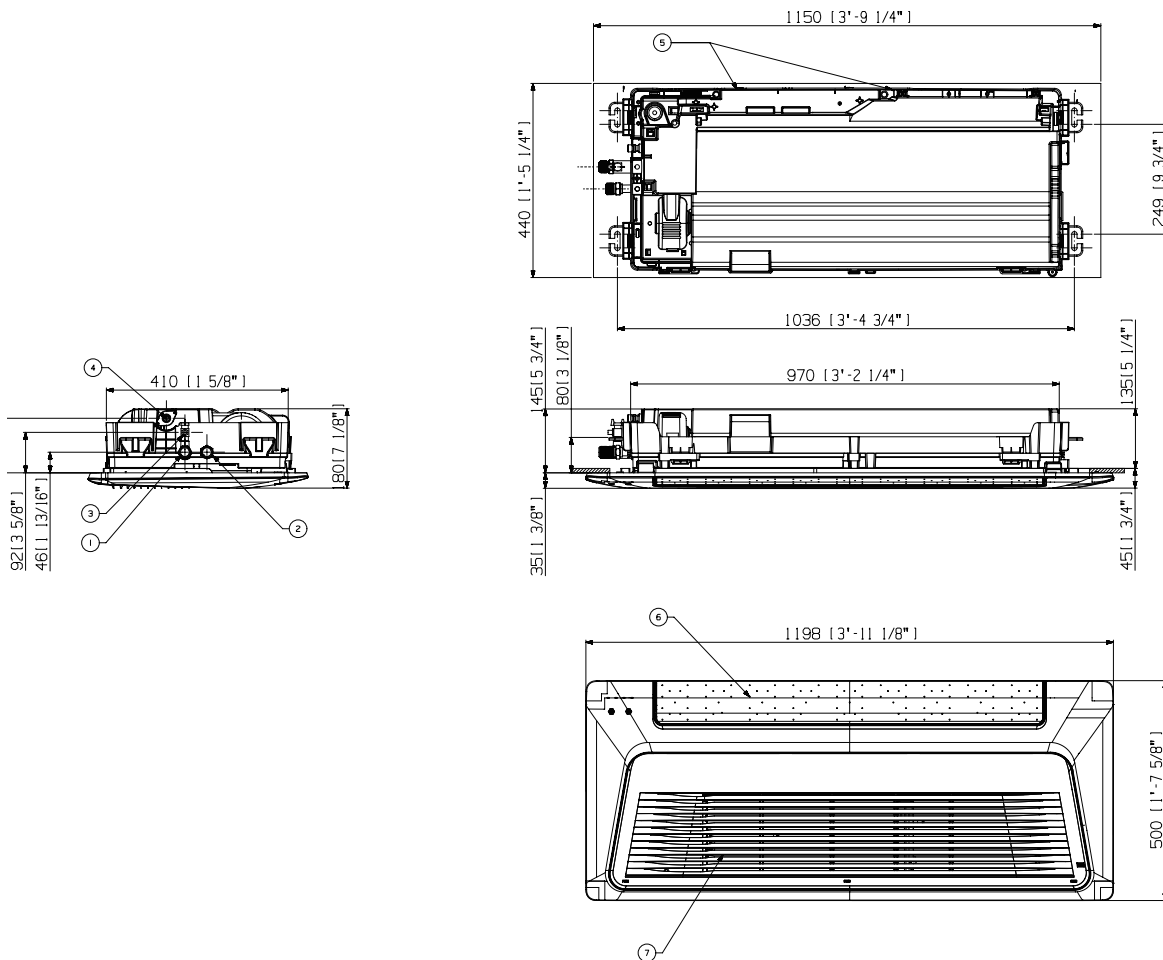

NO	Name	Description
1	Water pipe connection out	PF Male 3/4" (20A)
2	Water pipe connection in	PF Male 3/4" (20A)
3	Air vent valve	
4	Drain hose	VP20 (OD 26, ID 20)
5	Power supply/communication wiring conduits	
6	Air discharge part	
7	Air suction part	

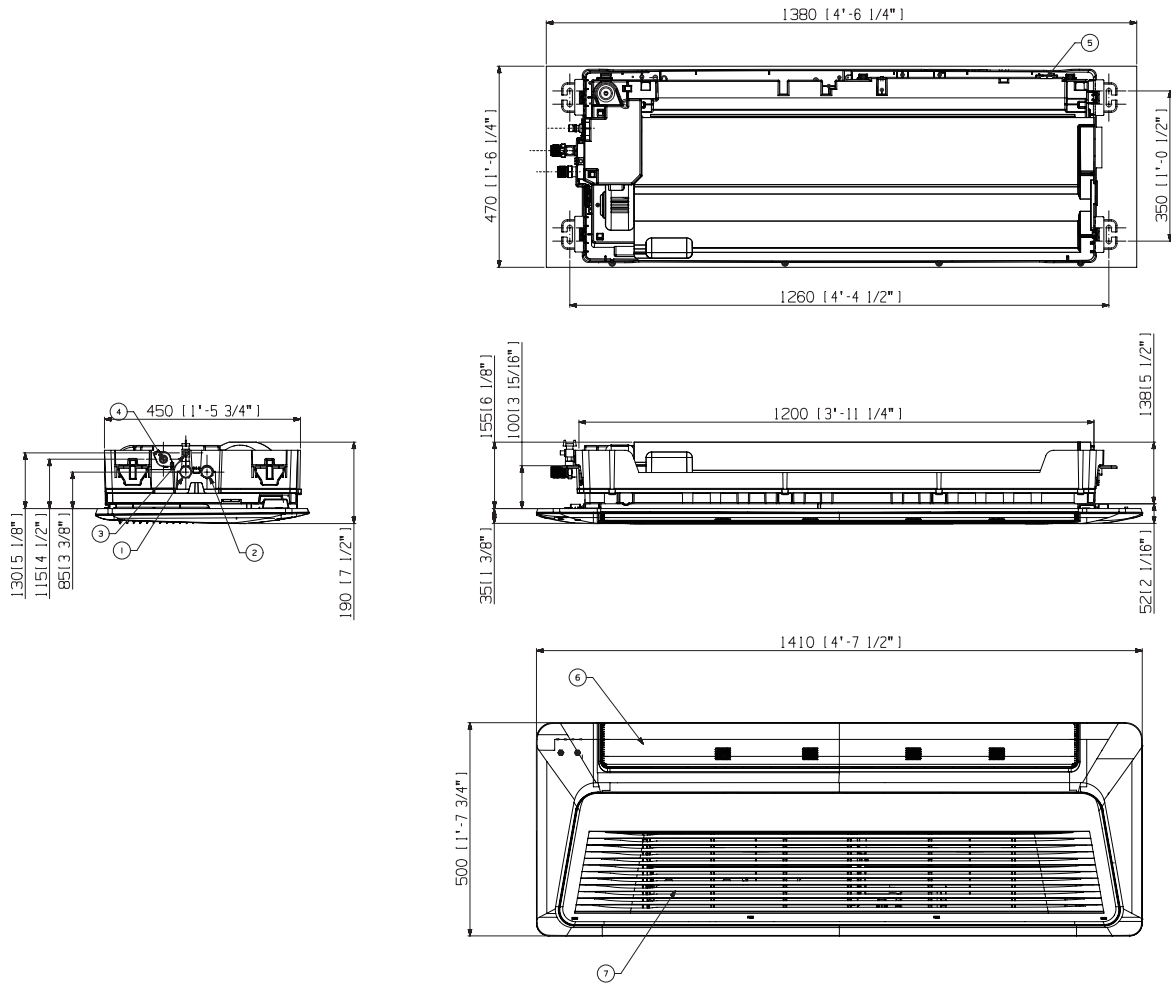

NO	Name	Description
1	Water pipe connection out	PF Male 3/4" (20A)
2	Water pipe connection in	PF Male 3/4" (20A)
3	Air vent valve	
4	Drain hose	VP25 (OD 32, ID 25)
5	Power supply/communication wiring conduits	
6	Air discharge part	
7	Air suction part	

Dimensional drawings

WindFree™ 4-Way Cassette FCU

AG060/072/090/105AN4DKH/EU

Units: mm [inches]

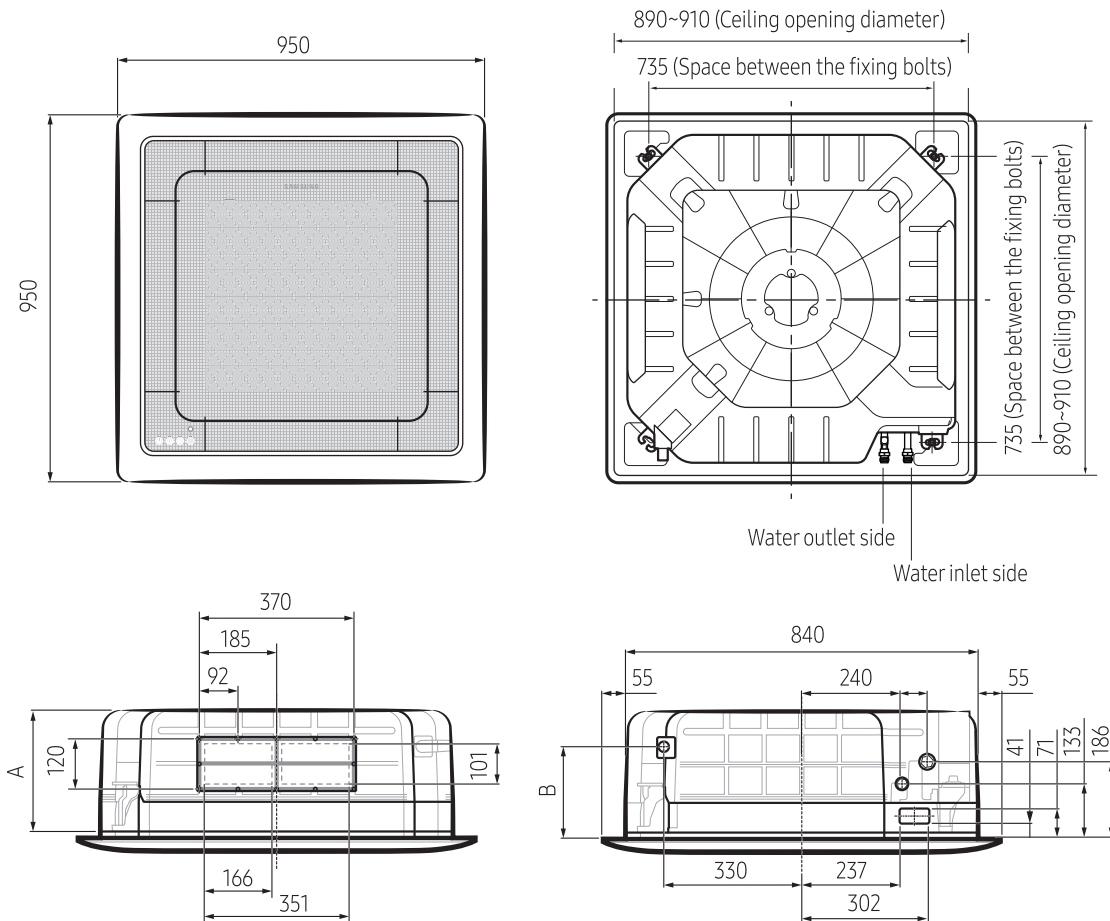

The sub duct hole is not applicable to the WindFree™ models.

Category	Type A	Type B
Model	AG060*N4DKH*	AG090*N4DKH*
	AG072*N4DKH*	AG105*N4DKH*
A (mm)	204	246
B (mm)	196	222
Connection port (mm)	PF 3/4" Male	
Flexible hose connection port (mm)	VP25 (outer diameter: Ø32, inner diameter: Ø25)	



Dimensional drawings

360 Cassette FCU

AG060/072/090/105MN4PKH/EU

Units: mm [inches]

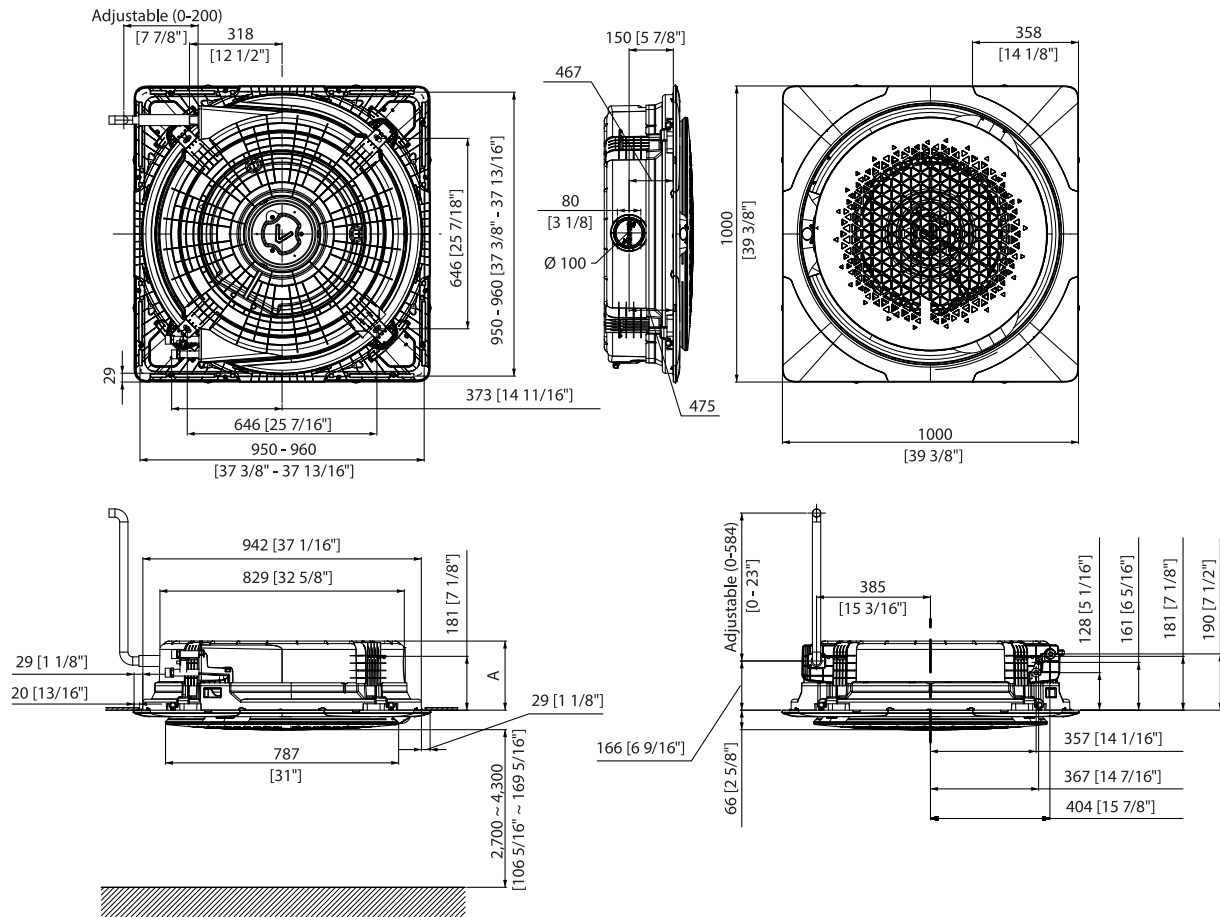

Pos.	A Type	B Type
Model	AG060MN4PKH/EU	AG072MN4PKH/EU AG090MN4PKH/EU AG105MN4PKH/EU
A	233 [9 3/16"]	317 [12 1/2"]
Pipe connection	PF 3/4 Male	
Drain pipe connection		VP25 (OD 32, ID 25)

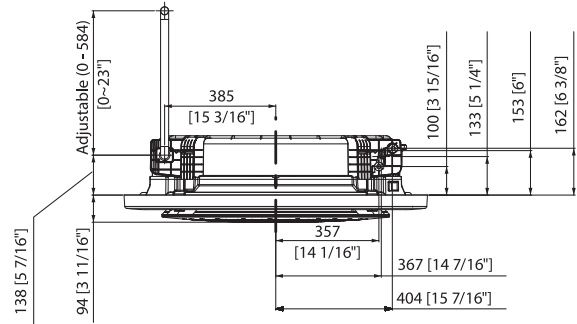
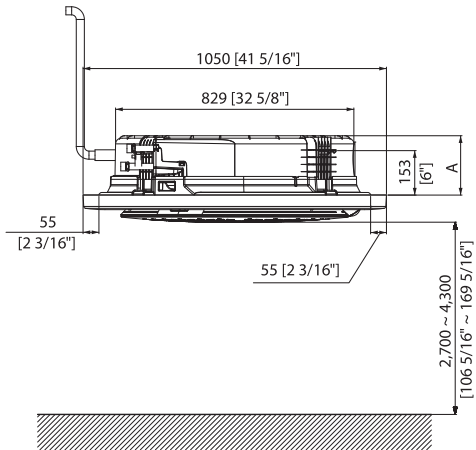
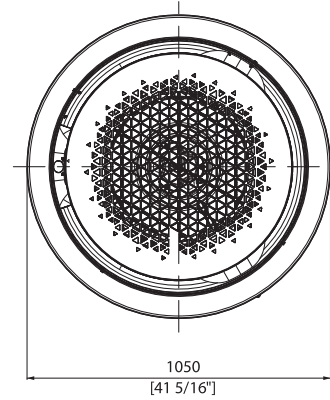
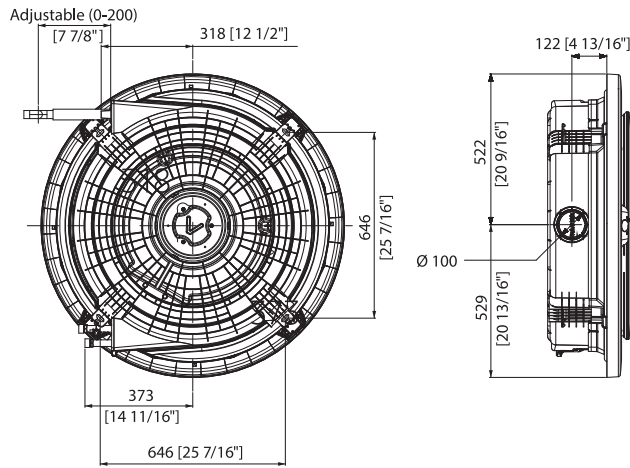

Pos.	A Type	B Type
Model	AG060MN4PKH/EU	AG072MN4PKH/EU AG090MN4PKH/EU AG105MN4PKH/EU
A	205	289
Pipe connection		PF 3/4 Male
Drain pipe connection		VP25 (OD 32, ID 25)

Dimensional drawings

Concealed FCU

ACL-**DF

Units: mm [inches]

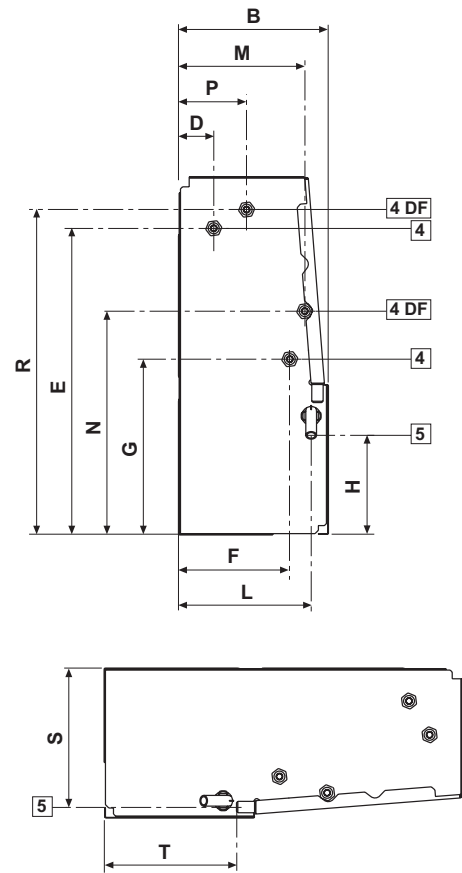
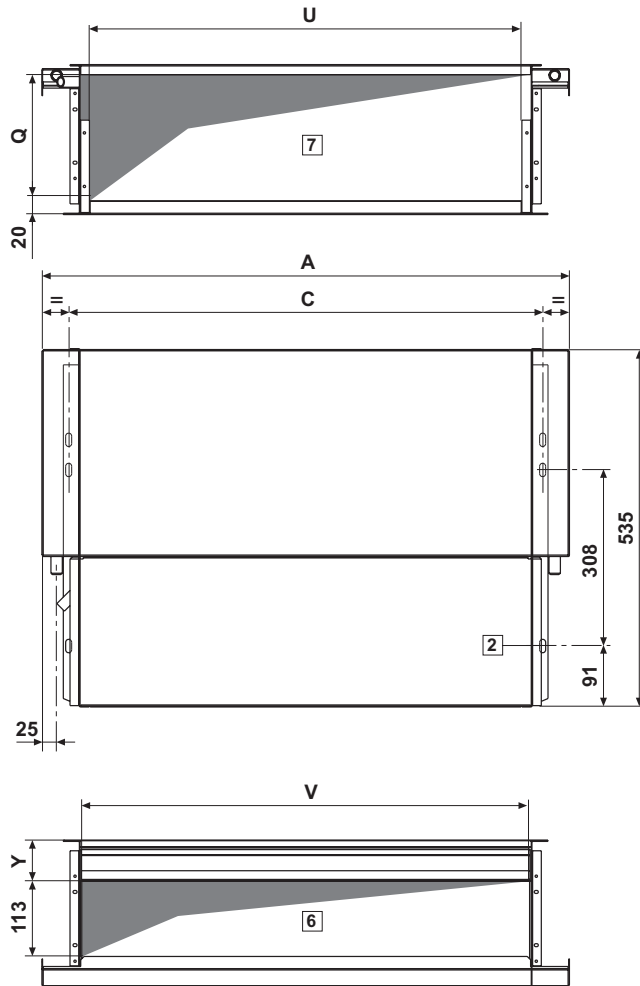

NO	Name	Description
1	Water pipe connection out	PF Male 3/4 (20A)
2	Water pipe connection in	PF Male 3/4 (20A)
3	Air vent valve	
4	Drain hose	VP25 (OD 32, ID 25)
5	Power supply/communication wiring conduits	
6	Air discharge part	
7	Air suction part	

MODEL	A	B	C	H	L	S	T	Y
ACL-18DH	584	224	498	149	198	208	198	61
ACL-25DH	794	224	708	149	198	208	198	61
ACL-35DH	1004	224	918	149	198	208	198	61
ACL-55DH	1214	249	1128	155	220	234	208	67
ACL-65DH	1214	249	1128	155	220	234	208	67

Dimensional drawings

Cased FCU

ACL-**DG

Units: mm [inches]

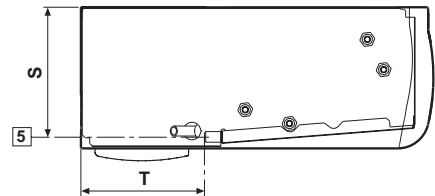
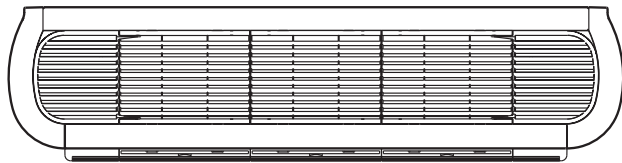
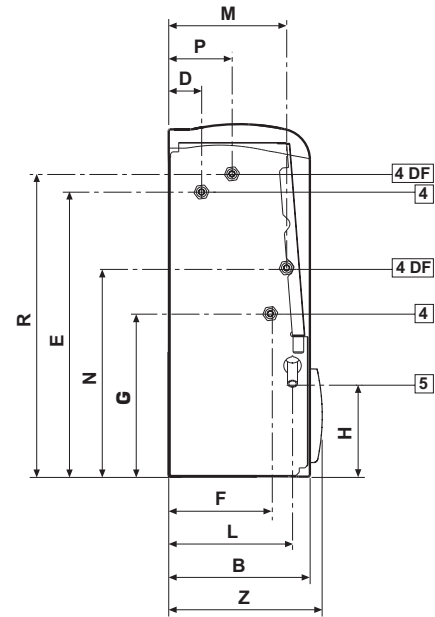
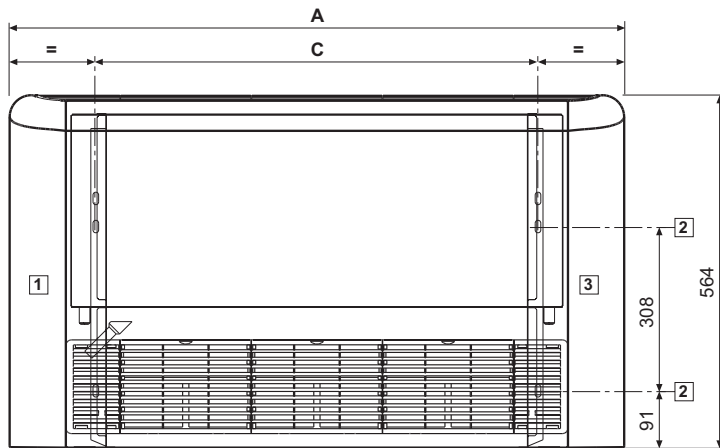

NO	Name	Description
1	Water pipe connection out	PF Male 3/4 (20A)
2	Water pipe connection in	PF Male 3/4 (20A)
3	Air vent valve	
4	Drain hose	VP25 (OD 32, ID 25)
5	Power supply/communication wiring conduits	
6	Air discharge part	
7	Air suction part	

MODEL	A	B	C	H	L	S	T	Z
ACL-18DG	774	226	498	149	198	208	198	246
ACL-25DG	984	226	708	149	198	208	198	246
ACL-35DG	1194	226	918	149	198	208	198	246
ACL-55DG	1404	251	1128	155	220	234	208	271
ACL-65DG	1404	251	1128	155	220	234	208	271





Ventilation

ERV brings fresh air to your workplace

An Energy Recovery Ventilation (ERV) system helps to maintain a fresh indoor environment in shared spaces such as an office, school, or retail space.

The ventilation solution improves indoor air quality and temperature by exchanging stale indoor air with fresh outdoor air. At the same time, it recovers the energy from the outgoing air using a heat exchanger and uses this to precondition the incoming air.





ERV (Plus)



Smart cooling auto mode

To conserve energy and remain cost-effective, the ERV and ERV Plus (for DVM) both automatically change operation modes depending on the indoor and outdoor temperatures. The ERV Plus (DVM only) is equipped with a direct expansion coil, which brings fresh outside air through the DX coil and into your space. It heats or cools, and can keep rooms at your desired temperature.

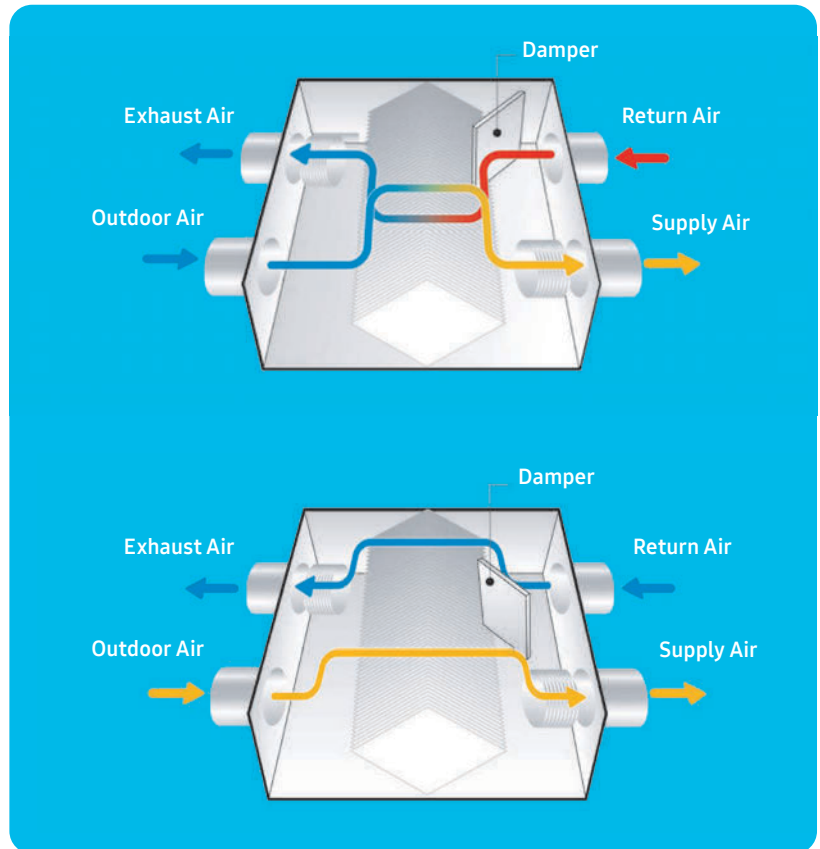

Instantly reduces CO₂ in your room

The ERV indoor unit has a CO₂ Sensor¹ that detects the level of CO₂ in the air and instantly draws in more outdoor air to maintain a comfortable environment. When the CO₂ level is low the fan speed will be lower and energy will be saved due to the lower power consumption of the fans and loss due to the ventilation of the room air.

¹ Optional, to be bought separately

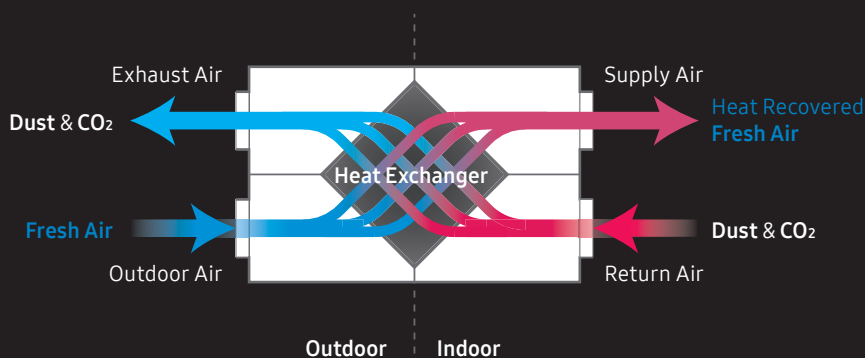



Specifications

ERV

- Energy recovery ventilation unit.
- Cellulose heat exchanger element.
- High Efficiency (F7 class) air filter.
- Optional CO₂ sensor for automatic regulation.
- Bypass operation mode when there's a small temperature difference between indoor and outdoor environment (automatically or manually operated).
- Interlocking with DVM S indoor units.
- Frost formation prevention without electric heater.



Model				AN026JSKLN/EU	AN035JSKLN/EU	AN050JSKLN/EU	AN080JSKLN/EU	AN100JSKLN/EU
Power Supply				Φ, #, V, Hz				
				1Φ, 2, 220-240 V, 50/60 Hz	1Φ, 2, 220-240 V, 50/60 Hz	1Φ, 2, 220-240 V, 50/60 Hz	1Φ, 2, 220-240 V, 50/60 Hz	1Φ, 2, 220-240 V, 50/60 Hz
Performance								
Air Volume				m ³ /h				
				260	350	500	800	1,000
Temperature Exchange Efficiency	Cooling	Turbo/High/Low	%	70/70/74	70/70/74	70/70/74	70/70/74	70/70/74
	Heating	Turbo/High/Low	%	74/74/75	78/78/79	74/74/75	77/77/78	74/74/75
Effective Enthalpy Exchange Efficiency	Cooling	Turbo/High/Low	%	50/50/55	50/50/55	50/50/55	50/50/55	50/50/55
	Heating	Turbo/High/Low	%	70/70/76	70/70/76	70/70/76	70/70/76	70/70/76
Power								
Power Input				Turbo/High/Low W				
				115/80/45	115/80/50	175/120/65	330/230/125	450/280/155
Current Input				Turbo A				
				0.7	0.7	1.1	2.1	2.9
Fan								
Airflow Rate				Turbo/High/Low m ³ /h				
				260/250/180	350/350/256	500/500/360	800/800/560	1,000/1,000/690
External Static Pressure				Turbo/High/Low Pa				
				100/65/55	155/100/83	165/100/85	155/90/80	155/90/75
Noise Level								
Sound Pressure ¹				Turbo/High/Low/ Quiet dB(A)				
				31/28/25/22	32/29/26/23	35/32/28/24	36/33/29/25	37/34/30/26
Sound Power				dB(A)				
				49	50	53	54	55
Field Wiring								
Power Source Wire				mm ²				
				1.5-2.5	1.5-2.5	1.5-2.5	1.5-2.5	1.5-2.5
Transmission Cable				mm ²				
				0.75-1.50	0.75-1.50	0.75-1.50	0.75-1.50	0.75-1.50
Dimensions								
Net Weight				kg				
				28.5	42.5	42.5	67.0	67.0
Net Dimensions (W x H x D)				mm				
				600 x 350 x 660	1,012 x 270 x 1,000	1,012 x 270 x 1,000	1,2220 x 340 x 1,135	1,2220 x 340 x 1,135
Supply/Return/Exhaust/Outside Duct Flange (Ø)				mm				
				150	200	200	250	250
Air Filter				Pre filter				

Accessories



Differential pressure switch²

MOS-P1050



ERV Wired Remote Controller

MWR-VH12N



Wired Remote Controller

MWR-WG01*N



CO₂ Sensor

MOS-C1

¹ Sound level was acquired in an anechoic room. Thus actual noise level may be different depending on the installation conditions.

² Please order MOS-P1050 separately. Differential pressure switch (model code: MOS-P1050) is a mandatory accessory for all ERV and ERV Plus units in EU countries according to Ecodesign Directive 1253/2014.

Specifications

ERV Plus for DVM S (R410A)

- Energy recovery ventilation unit with built-in direct expansion coil.
- Cellulose heat exchanger element.
- High Efficiency (F7 class) air filter.
- Two centrifugal fans direct driven by electric BLDC motor.
- Optional CO₂ sensor for automatic regulation.
- Bypass operation mode when there's a small temperature difference between indoor and outdoor environment (automatically or manually operated).
- Frost formation prevention without electric heater.
- Auto Restart function.



Model				AM050FNKDEH/EU	AM100FNKDEH/EU
Power Supply				1Φ, 2, 220-240 V, 50 Hz	1Φ, 2, 220-240 V, 50 Hz
Performance					
Temp. Exchange Efficiency	Cooling	Turbo/High/Low	%	70/70/74	70/70/74
	Heating	Turbo/High/Low	%	75/75/79	75/75/79
Effective Enthalpy Exchange Efficiency	Cooling	Turbo/High/Low	%	60/60/66	62/62/68
	Heating	Turbo/High/Low	%	73/73/79	75/75/81
Outside Air Processing Capacity	Cooling (DX Coil/Element)		-	5.1 (3.6/1.5)	10.5 (7.1/3.4)
	Heating (DX Coil/Element)		-	6.5 (4.0/2.5)	13.2 (8.0/5.2)
Fan					
Airflow Rate	Turbo/High/Low (UL)		m _v /hr	500/500/360	1,000/1,000/690
			l/s	138.9/138.9/100.0	277.8/277.8/191.7
External Static Pressure	Turbo/High/Low		mmAq	16.30/10.20/8.70	15.30/9.20/7.60
			Pa	160.00/100.00/85.00	150.00/90.00/75.00
Motor	Type		-	BLDC	BLDC
	Output		W	60	70
	Quantity		ea	2	2
Power					
Power Input	Turbo/High/Low		W	220/140/90	510/350/235
Current Input	Turbo/High/Low		A	1.7/1.0/0.6	3.7/2.4/1.6
Piping Connections					
Liquid Pipe			Ø, mm	6.35	6.35
			Ø, inch	1/4	1/4
Gas Pipe			Ø, mm	12.70	12.70
			Ø, inch	1/2	1/2
Drain Pipe			Ø, mm	VP25 (OD 32, ID 25)	VP25 (OD 32, ID 25)
			Ø, inch	VP25 (OD 1-1/4", ID 1")	VP25 (OD 1-1/4", ID 1")
Water Supply			Ø, mm	12.70	12.70
			Ø, inch	1/2	1/2
Field Wiring					
Power Source Wire			mm ²	1.5/2.5	1.5/2.5
Transmission Cable			mm ²	0.75-1.50	0.75-1.50
Refrigerant					
Type			-	R410A (Fluorinated greenhouse gas, GWP=2,088)	
Control Method			-	EEV	EEV
Sound					
Sound Pressure ¹	Turbo/High/Low		dB(A)	36/32/28	36/33/31
Sound Power			dB(A)	67	67
Dimensions					
Net Weight			kg	61.0	90.0
Net Dimensions (W x H x D)			mm	1,553 x 270 x 1,000	1,763 x 340 x 1,135
Supply/Return/Exhaust/Outside Duct Flange (Ø)			mm	200	250
Ambient Conditions					
Around Unit			-	0-40 °C DB, 80 % RH or less	0-40 °C DB, 80 % RH or less
Outdoor Air			-	-15-40 °C DB, 80 % RH or less	-15-40 °C DB, 80 % RH or less
Return Air			-	0-40 °C DB, 80 % RH or less	0-40 °C DB, 80 % RH or less
Air Filter				Pre filter	Pre filter

Controls



Wired Remote Controller

MWR-WG00*N

Accessories



Differential pressure switch²

MOS-P1050



CO₂ Sensor

MOS-C1

¹ Sound level was acquired in an anechoic room. Thus actual noise level may be different depending on the installation conditions.

² Please order MOS-P1050 separately. Differential pressure switch (model code: MOS-P1050) is a mandatory accessory for all ERV and ERV Plus units in EU countries according to Ecodesign Directive 1253/2014.

Specifications

OAP Duct for DVM S (R410A)

- 100% outdoor air unit.
- Equipped with two Sirocco fans direct driven by a single motor.
- Only discharge temperature control.
- No limitation in OAP Duct quantity for one system.
- Auto ESP function: the fan speed is adjustable according to ductwork external static pressure.
- Can be combined with other DVM indoor units to form one system.



Model			AM140MNEPEH/EU	AM220MNEPEH/EU	AM280MNEPEH/EU
Power Supply			Φ, #, V, Hz		
			1Φ, 2, 220-240 V, 50 Hz	1Φ, 2, 220-240 V, 50 Hz	1Φ, 2, 220-240 V, 50 Hz
Performance					
Capacity (Nominal)	Cooling	kW	14.0	22.4	28.0
	Heating	kW	8.9	13.9	17.4
Power					
Power Input (Nominal)	Cooling	W	300	450	600
	Heating	W	300	450	600
Current Input (Nominal)	Cooling	A	2.2	3.5	4.6
	Heating	A	2.2	3.5	4.6
Heat Exchanger					
Type			Fin & tube	Fin & tube	Fin & tube
Material			Al	Al	Al
			Cu	Cu	Cu
Fan					
Motor	Type	-	Sirocco Fan	Sirocco Fan	Sirocco Fan
	Output x n	W	183 x 1	630 x 1	630 x 1
	Number of Fans	ea	2	2	2
Airflow Rate	H/M/L	m ³ /min	18	28	35
			l/s	300.0	466.7
External Pressure	Min/Std/Max	mmAq	15.30/20.40/25.50	18.40/23.40/29.60	20.40/25.50/30.60
		Pa	150.00/200.00/250.00	180.00/230.00/290.00	200.00/250.00/300.00
Piping Connections					
Liquid Pipe	Ø, mm		9.52	9.52	9.52
	Ø, inch		3/8	3/8	3/8
Gas Pipe	Ø, mm		15.88	19.05	22.22
	Ø, inch		5/8	3/4	7/8
Drain Pipe	Ø, mm		VP25 (OD 32, ID 25)	VP25 (OD 32, ID 25)	VP25 (OD 32, ID 25)
Field Wiring					
Transmission Cable	Min.	mm ²	0.75	0.75	0.75
Refrigerant					
Type			R410A(Fluorinated greenhouse gas, GWP=2,088)		
Control Method			EEV (INCLUDED)	EEV (INCLUDED)	EEV (INCLUDED)
Noise Level					
Sound Pressure ¹	H/M/L	dB(A)	42	46	47
Sound Power	Cooling	dB(A)	65	66	69
Dimensions					
Net Weight			49.0	81.5	81.5
Net Dimensions (W x H x D)			1210 x 370 x 656	1,360 x 460 x 910	1,360 x 460 x 910
Additional Accessories					
Drain Pump	Drain Pump	-	MDP-M075SGU2D	MDP-G075SP	MDP-G075SP
	Max. Lifting Height/Displacement	mm / litres/h	750/24	750/24	750/24

Controls



Wireless Remote Controller	Wireless Remote Controller	Wireless Receiver Kit	Touch Controller	Wired Remote Controller	Wi-Fi Kit
AR-CH01E	AR-EH03E (to be matched with MRK-A10N)	MRK-A10N (to be matched with AR-EH03E)	MWR-SH11N	MWR-WG01*N	MIM-H04EN

Accessories



External Room Sensor	Drain Pump (optional)	Drain Pump (optional)
MRW-TA	MDP-G075SP/Q	MDP-N047SNC1D

¹ Sound level was acquired in an anechoic room. Thus actual noise level may be different depending on the installation conditions.



Dimensional drawings

ERV

AN026JSKLN/EU

Units: mm [inches]

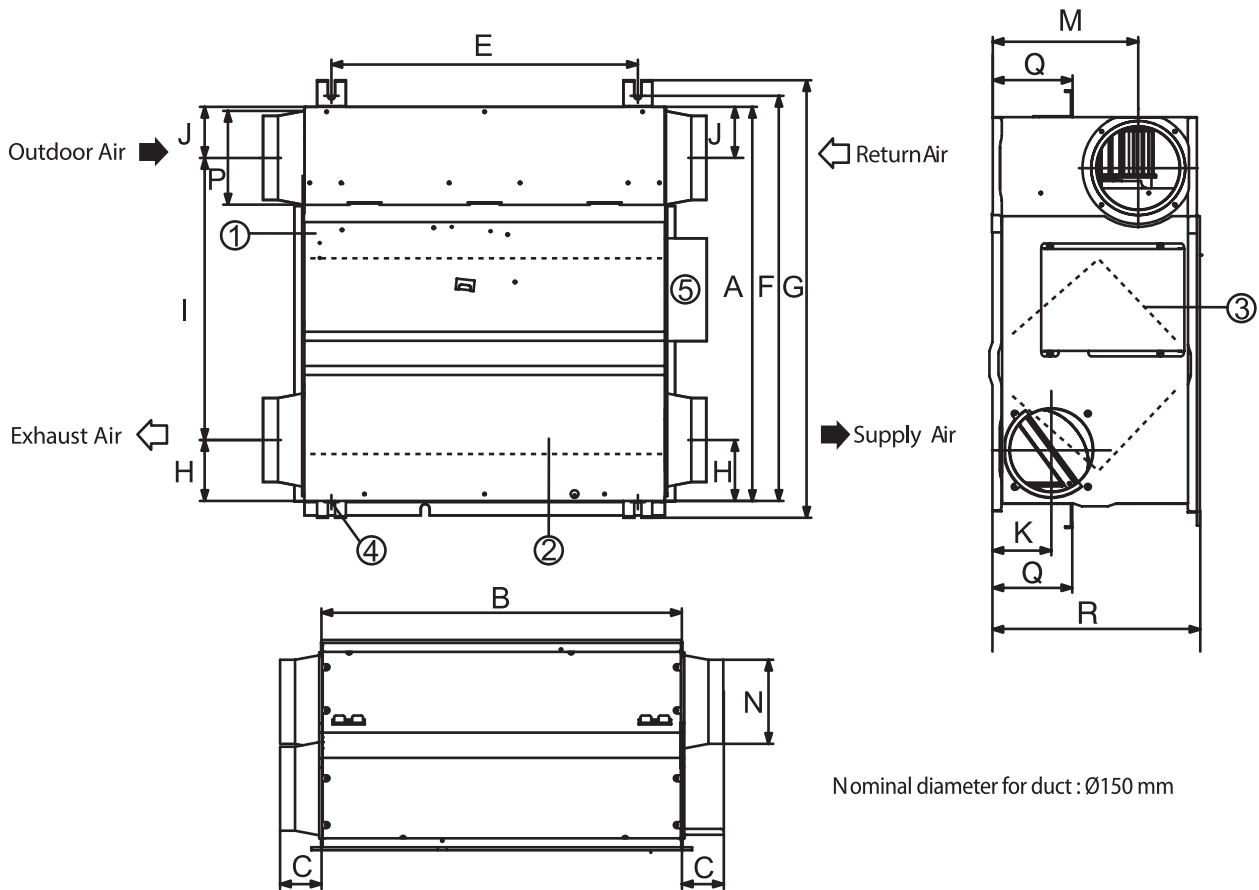

Nominal diameter for duct : Ø150 mm

NO	Name	Description
1	Maintenance cover	1
2	Heat exchange element	1
3	Dust filter	2
4	Hanger	4
5	Electrical component box	1

Model	A	B	C	E	F	G	H	I	J	K	M	N	P	Q	R
	Length (mm)										Diameter (mm)		Length (mm)		
026	600	660	70	510	675	729	102	470	85	98	242	140	156	133	350

Dimensional drawings

ERV Plus for DVM S (R410A)

AM***FNKDEH/EU

Units: mm [inches]

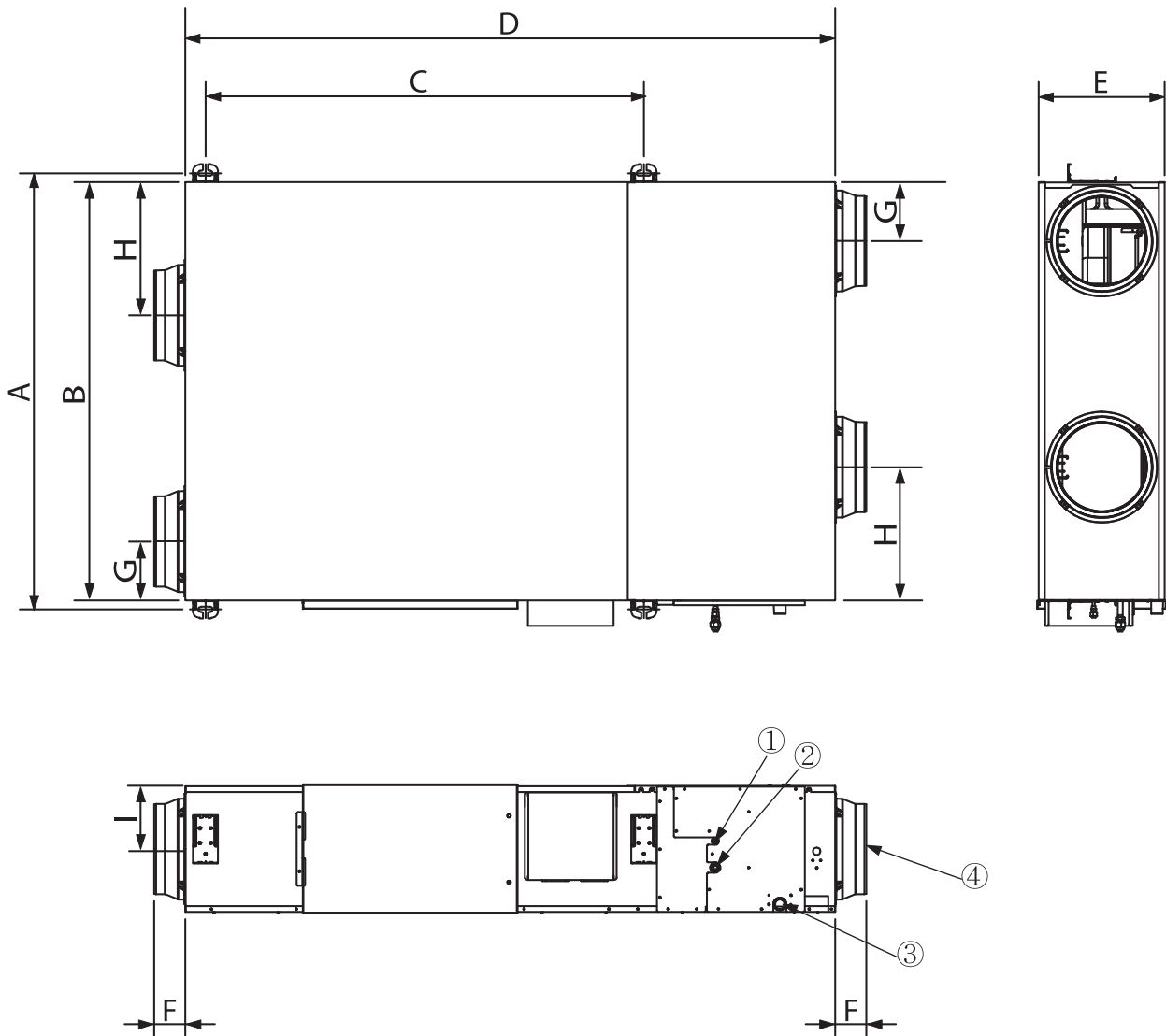

NO	Name	Description	
		AM050FNKDEH	AM100FNKDEH
1	Liquid pipe connection		Ø6.35 Flare
2	Gas pipe connection		Ø12.70 Flare
3	Drain pipe connection		VP25 (OD 32, ID 25)
4	Nominal diameter for duct	Ø200	Ø250

Model	A	B	C	D	E	F	G	H	I
RHF050KHEA	1,036	1,000	987	1,553	270	99	130	253	135
RHF100KHEA	1,183	1,135	1,189	1,763	340	84	160	362	170

Dimensional drawings

ERV

035/050 - 080/100

Units: mm [inches]

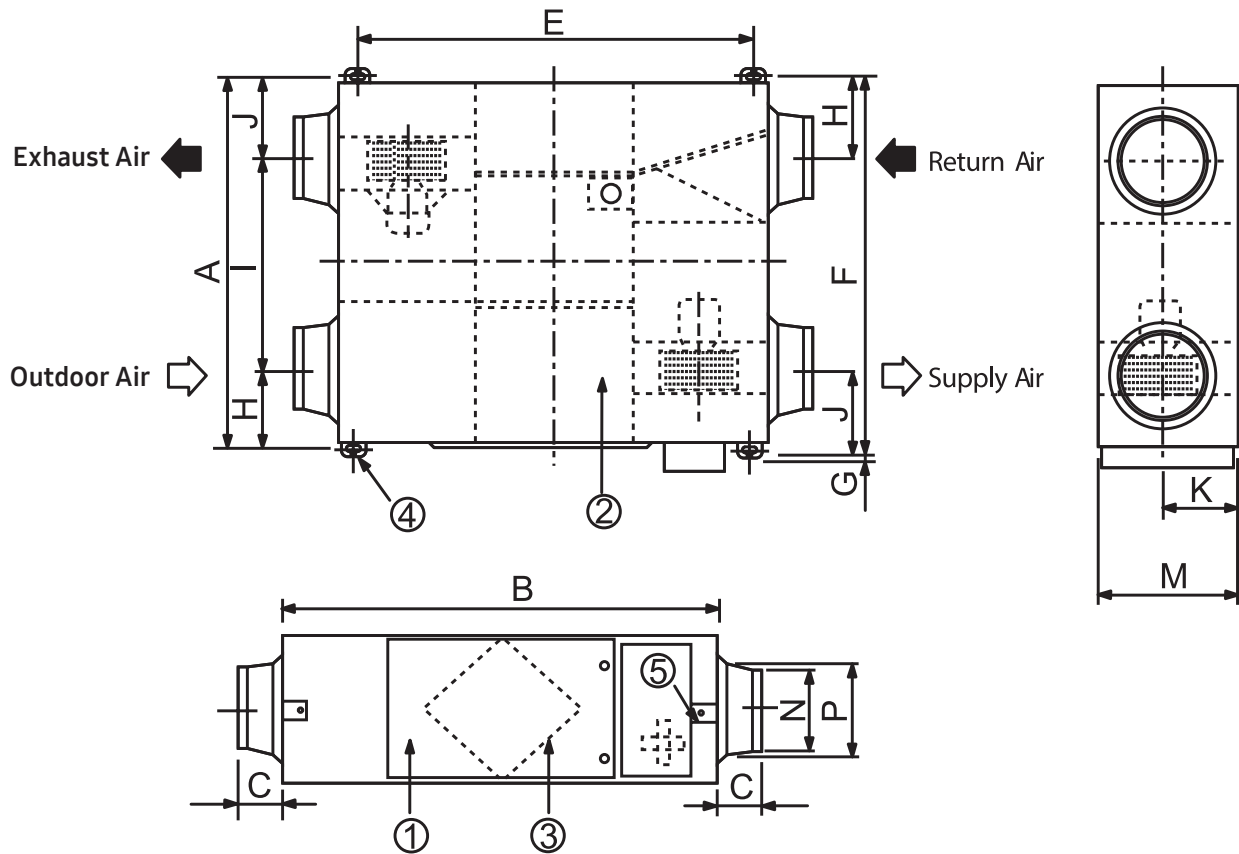

NO	Name	Description
1	Maintenance cover	1
2	Heat exchange element	2
3	Dust filter	4
4	Hanger	4
5	Electrical component box	1

Model	Nominal diameter for duct (mm)
035/050	200
080/100	250

Model	A	B	C	E	F	G	H	I	J	K	M	N	P	Q	R
Length (mm)											Diameter (mm)		Length (mm)		
035/050	1,000.00	1,012.00	99.00	940.60	1,036.40	26.00	130.00	617.00	253.00	135.00	270.00	194.00	241.50	133.00	350.00
080/100	1,135.00	1,220.00	84.00	1,110.00	1,183.00	25.00	184.00	613.25	387.75	170.00	340.00	244.00	270.00		

Dimensional drawings

OAP Duct for DVM S (R410A)

AM140MNEP*H

Units: mm [inches]

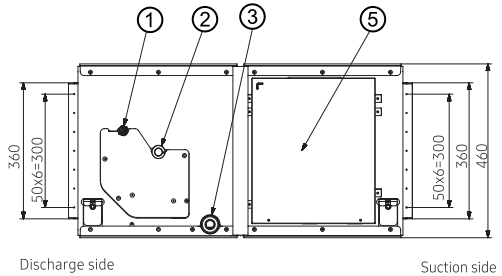
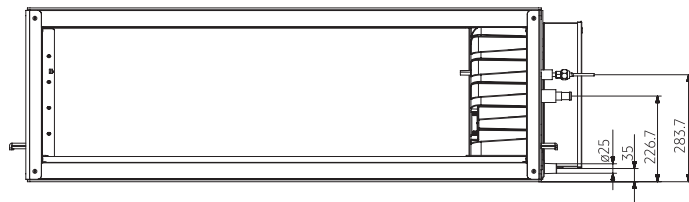
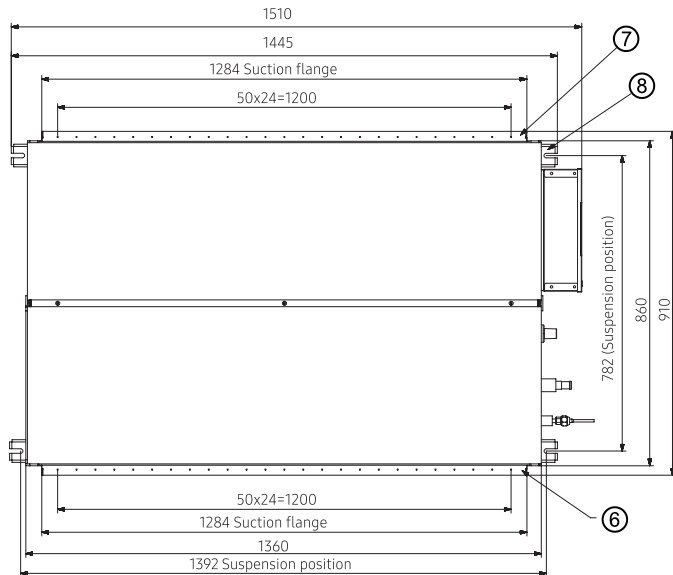

Discharge side

Suction side

NO	Name	Description
1	Diameter of liquid pipe	Ø9.52
2	Diameter of air pipe	Ø15.88
3	Diameter of drain pipe	OD Ø25, ID Ø20
4	Diameter of drain pipe (Optional drain pump)	OD Ø25, ID Ø20
5	Power supply/Communication wiring conduit	
6	Air discharge grille flange	
7	Suction flange	
8	Hook	Ø9.52 or M10

Controls





System Air Conditioner

Touch Centralized Controller 2.0

A 253.5 mm LCD display with touch controls eliminates the physical buttons from the front. Its minimalist design, which is fully covered in glass with a narrow metallic frame, means it simply blends with any interior style while improving usability.

Operation Summary

Quickly monitor the number of devices in operation or to be serviced at a glance.



Scheduling

Simply set the operation schedules of multiple devices - all at once or individually.

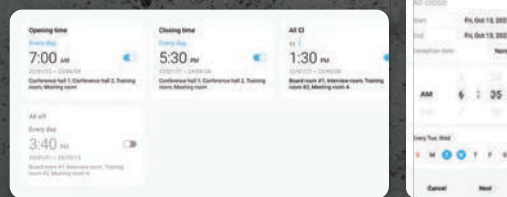

Energy Usage Monitor

Efficiently manage energy use by visually comparing the real-time consumption with the previous periods*.



I Detailed view of energy consumption

* By day, week, month and year.
*** The information provided includes estimated figures intended solely for illustrative and indicative purposes. Actual consumption depends on various factors and other usage conditions.

Air Quality Monitor

Check the real-time air quality of each room in your workplace at a glance.



I Detailed view of the real-time air quality*



Customizable to harmoniously blend into your space

The cover screen and home screen can be easily customized as you want. Simply select your favorite wallpaper from the gallery or upload your own one* to suit your taste and interior style.

* Only PNG, GIF and JPG format images with a file size of less than 10MB are supported.

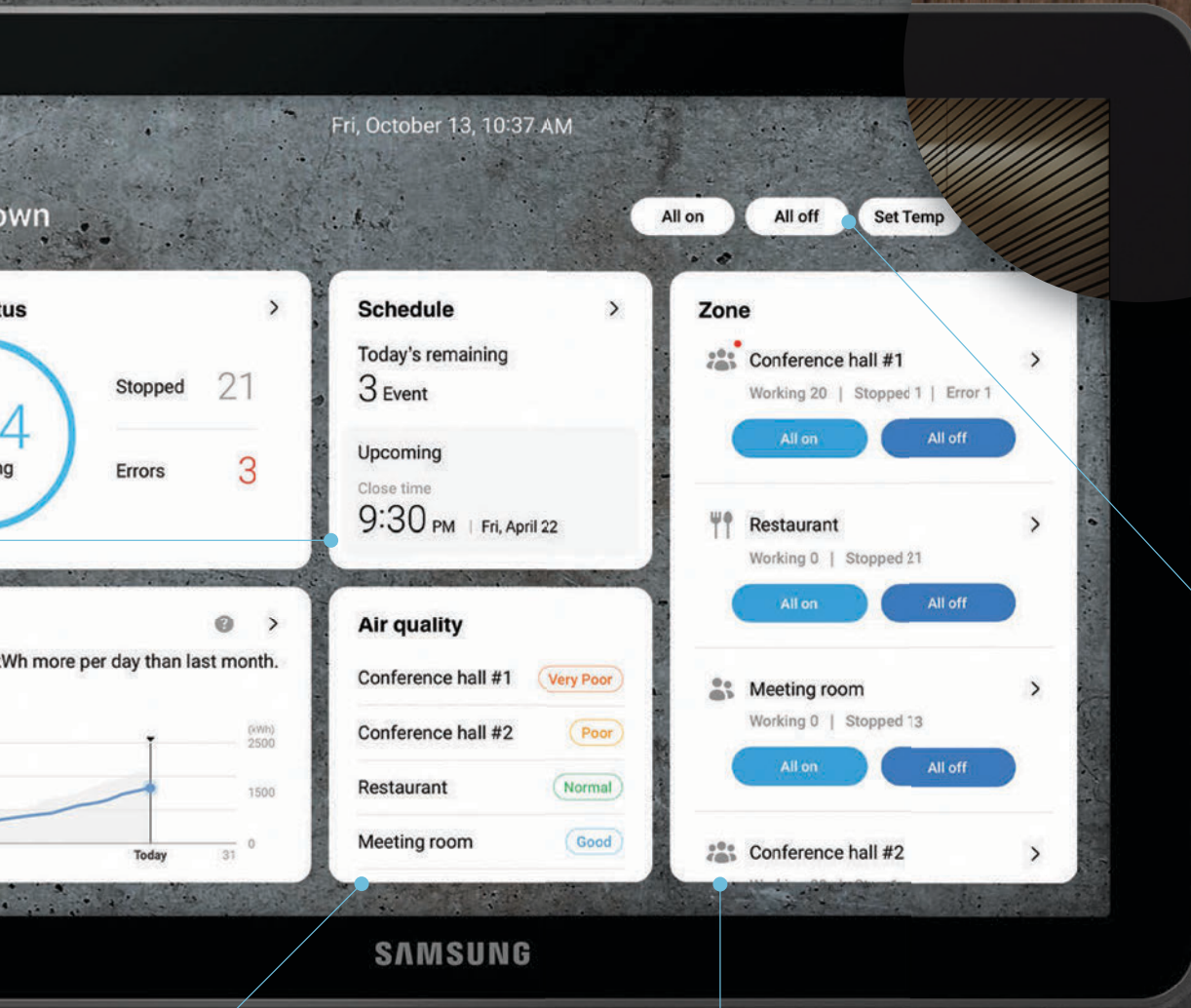

Zone Control

Set zones, based on the location, usage and operating time, to efficiently monitor and control devices simultaneously.

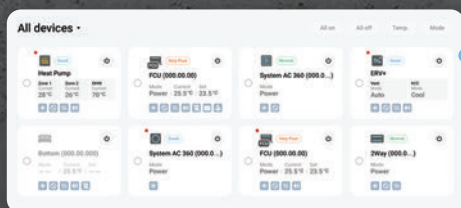

Multi-device Control

Control all devices at once, including power on/off, modes and temperatures.

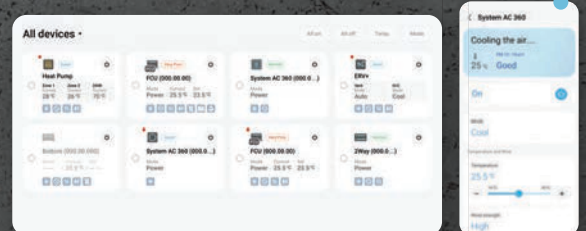

* The screen image is for illustrative purposes only and may differ from the actual user interface on your controller based on the OS version and actual usage situation.

* The above product image has the same dimensions as the actual product.

* New in 2024. Only available when using certain indoor units that have an Air Quality Sensor.

Intuitive Control

SmartThings Style UI

With a simplified layout and icons, you can easily monitor and control the entire system from one spot. If you are familiar with SmartThings then you will intuitively know how to use it.

- Consistent user experience across Samsung appliances, based on SmartThings and One UI
- High Visibility with a simple layout and icons
- 2D Layout view*

* New

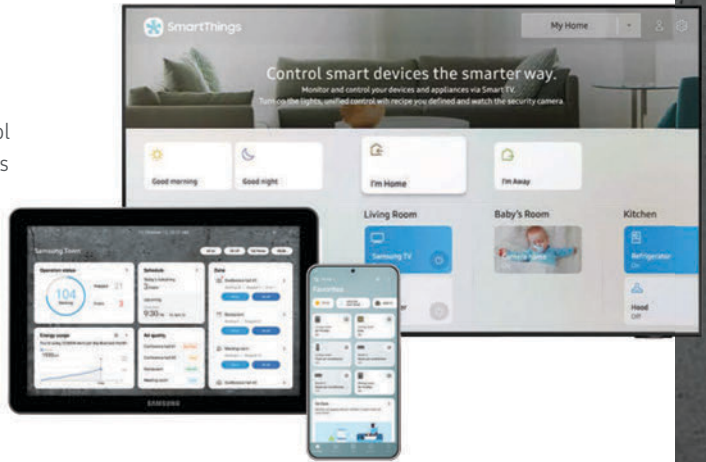

Efficient Management

Dashboard on the Home Screen

Intuitively check the current status and easily control everything in your workplace. From scheduling to the MDS*, you can automate the performance of the air conditioning to optimize your comfort and energy savings.

- One-stop scheduling on multiple devices and zones
- Quick access to the settings for the MDS*
- Electric Current Control** for balancing the energy load

* MDS: Motion Detection Sensor.
** New



Effortless Service

Service History

Get a real-time notification when an error occurs, and view the history of any troubleshooting at a glance. Based on the accumulated data, errors can be quickly addressed and solved.

- Real-time notification of errors
- Troubleshooting history management of up to 1 year



System Configuration

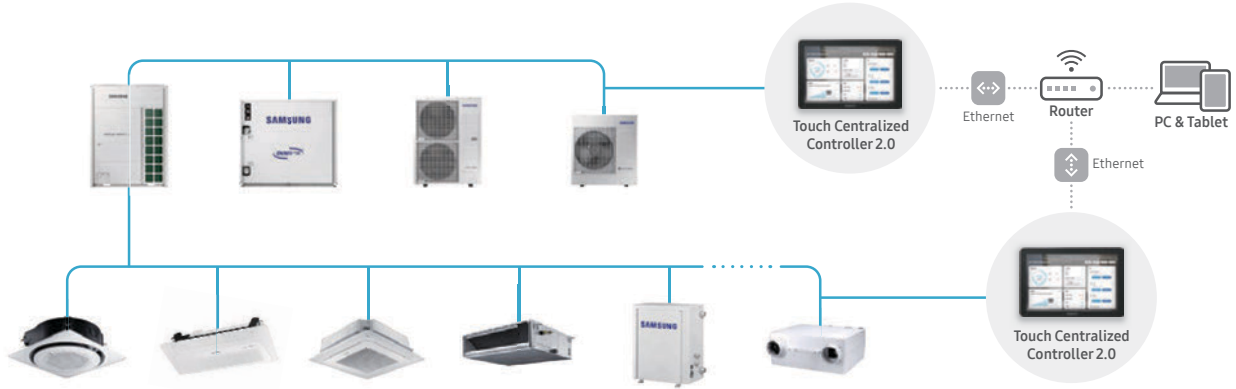

* Please contact your installer or sales expert of Samsung Air Conditioner to connect to ventilation systems (* shown above), including the Samsung ERV and ERV Plus.
 * The number of devices (indoor and outdoor units) that can be connected will differ based on the location of the controller's connection ports.

Specifications













- Dimensions (WxHxD in mm): 245.7 x 164.5 x 30.9
- Display Size (WxH in mm): 215.2 x 134 (253.5 mm TFT LCD)
- Display Resolution (WxH in px): 1,280 x 800











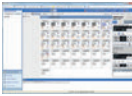





Model Name		MCM-A300BN*	
Connection	Indoor Units	Up to 128	
Layer	Set (F1/F2)	•	
	Control (R1/R2)	•	
Hardware	Power Supply	DC 12V (Adapter: AC 100-240V, 50/60 Hz)	
	Memory	RAM	3 GB
		Flash	16 GB
	External Port	DI/DO	2 EA / 2 EA
		SD Card Slot	Micro SD 1 EA
		RJ45 (LAN)	1 EA (1 Gbps)
		RS485 (NASA)	Quantity
	F1, F2 Wiring	1 Outdoor Unit per Port / Up to 64 Indoor Units per Port	
	R1, R2 Wiring	Up to 16 Outdoor Units per Port (including Module) / Up to 128 Indoor Units per Port (Port 1 + Port 2)	
Software (Function)	Energy Saving	•	
	Power Consumption	•	
	Air Quality	•	
Expandable Device	In-site (Connection with Local Network)	PC/Tablet	
	Supported Browser (PC/Tablet)	Web (Chrome)	























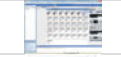



* Features and specifications are subject to change without notice for the improvement of performance.

Line-up

Product	Model	Image	Matchable Products
Individual Control System			
Wireless Remote Controller	AR-EH03E AR-EH04E*		FJM, CAC, DVM, FCU *only for FCU 1-Way/4-Way Cassette
Wireless Remote Controller SolarCell	AR-CH01E	 NEW	TDM, FJM, CAC, CAC HEE, DVM, FCU *also for 360 Cassette
Wired Remote Controller	MWR-WG01JN MWR-WG01KN	 NEW	FJM, CAC, DVM, ERV, FCU *Added Safety measures for DVM R32
	MWR-WW00N MWR-WW10N MWR-WW10JN MWR-WW10KN		DVM *only for Hydro unit
Simple Type Controller	MWR-SH00N		CAC, DVM, FCU
Touch Type Controller	MWR-SH11N		CAC, DVM, FCU (with WindFree™ function)
ERV Wired Remote Controller	MWR-VH12N		ERV
Wireless Receiver Kit	MRK-A10N		CAC, DVM *only for duct models
Centralised Control System			
ON/OFF Controller	MCM-A202DN		FJM, CAC, DVM, ERV Plus, HVM Chiller
Touch Centralised Controller 2.0	MCM-A300BN		FJM, CAC, DVM, ERV Plus, HVM Chiller
Wi-Fi Kit	MIM-H04EN		All (except HVM Chiller & 3rd party FCU)
Module Controller	MCM-A00N		HVM Chiller

Product	Model	Image	Matchable Products
Integrated Management System			
DMS2.5	MIM-D01AN		FJM, CAC, DVM, ERV Plus, HVM Chiller
S-NET3	MST-P3P		
b.IoT Lite Software	MST-BL1A		
Gateway & Interface			
BACnet Gateway	MIM-B17BN		FJM, CAC, DVM, ERV Plus, HVM Chiller
LonWorks Gateway	MIM-B18BN		FJM, CAC, DVM, ERV Plus, HVM Chiller
External Contact Interface Module	MIM-B14 (KEY TAG) MIM-B14A (LEAK DETECTION)		RAC, FJM, CAC, DVM, HVM Chiller
PIM (Pulse Interface Module)	MIM-B16N		FJM, CAC, DVM, ERV Plus, HVM Chiller
MODBUS Gateway	MIM-B19N		FJM, CAC, DVM, ERV Plus, HVM Chiller
Interface Module (Converter RS485 to NASA)	MIM-N01		FJM, CAC
ERV Interface Module (Converter RS485 to NASA)	MIM-N10		ERV
FCU Kit	MIM-F00N		Concealed & Cased FCU
FCU Interface Module	MIM-F10N		FCU
Installation/Test Run Solution			
S-Converter	MIM-C02N MIM-S10N (TBD)		
Others			
External Room Sensor	MRW-TA		FJM, CAC, DVM
Operation Mode Selection Switch	MCM-C200		
MTFC (Multi-Tenant Function Controller)	MCM-C210N		

Compatibility guide

Product	Model	Image	Compatibility		
			DVM	HVM Chiller	FCU1W/4W/360
Individual Control System					
Wireless Remote Controller	AR-EH03E		•		•
Wireless Remote Controller (360 Cassette)	AR-CH01E	 NEW	•		•
Wired Remote Controller	MWR-WG01JN	 NEW	•		•
	MWR-WG01KN		•		•
	MWR-WW00N MWR-WW10*N (DVM Hydro)		•		
Simple Type Controller	MWR-SH00N		•		•
Touch Controller	MWR-SH11N		•		•
ERV Wired Remote Controller	MWR-VH12N				
Wireless Receiver Kit	MRK-A10N		•		
Centralised Control System					
Touch Centralised Controller 2.0	MCM-A300BN		•		
ON/OFF Controller	MCM-A202DN		•	•	
Wi-Fi Kit	MIM-H04EN		•		•
Module Controller	MCM-A00N			•	
Integrated Management System					
DMS 2.5	MIM-D01AN		•	•	
S-NET3	MST-P3P		•		
b.IoT Lite Software	MST-BL1A		•		
Gateway & Interface					
BACnet Gateway	MIM-B17BN		•	•	
Lonworks Gateway	MIM-B18BN		•	•	
Modbus Interface Module	MIM-B19N		•		
PIM (Pulse interface module)	MIM-B16N		•	•	
External Contact Interface Module	MIM-B14		•	•	
	MIM-B14A (refrigerant leakage detector)		•		
Interface Module Converter (RS485-NASA)	MIM-N01		•		
ERV Interface Module Converter (RS485-NASA)	MIM-N10				
FCU Interface Module	MIM-F00N				•
	MIM-F10N				
Installation/Test Run Solution					
S-Converter	MIM-C02N		•	•	
Others					
External Room Sensor	MRW-TA		•		
Operation Mode Selection Switch	MIM-C200		•		
MTFC (Multi-Tenant Function Controller)	MCM-210N		•		

Selection guide



NEW



NEW



Model	AR-CH01E	MWR-WG01*N	MWR-SH00N	MWR-SH11N	MWR-VH12N
Appearance					
Dimensions	35 x 160 x 13	120.0 x 120.0 x 19.0	75x122x16.6	94.2 x 122.0 x 19.5	75.0 x 122.0 x 16.6
Power					
USB-C charging	●				
Solar Cell panel	●				
Connection					
Indoor units control	●	●	●	●	
ERV control		●			●
Maximum connectable indoor units	1	16	16	16	6
Control & monitoring					
ON/OFF	●	●	●	●	●
Operation mode	●	●	●	●	●
Fan speed	●	●	●	●	●
Air swing		●	●	●	
Room temperature display	●	●			
°C convertible	●	●		●	
Filter cleaning alarm reset	●	●	●	●	
Air quality display		●			
Purification display	●	●			
Display indoor model number	●	●			
Error display		●	●	●	●
Error list		●			
Schedule					
Weekly schedule		●			
Simple ON/OFF timer	●		●	●	●
Convenient function					
Dual set point	●	●			
Multiple languages		●			
Built-in room sensor		●		●	
LCD backlight		●		●	
OLED	●				
Freeze Wash	●				
Wireless RC restriction		●	●	●	
Child lock		●	●	●	●
Partial button lock		●	●	●	●
Quiet mode	●	●	●	●	
Sleep mode	●	●		●	
Away mode (SAC)	●	●		●	
Away mode (ERV)					●
IR receiver		●		●	
Real-time clock					
Daylight saving time		●			
Individual blade control	●	●			
CO ₂ display		○ ERV			●
Purification mode		○ ERV			
Energy saving					
Temperature range limit	●	●	●	●	
Automatic operation stop		●			
Operation time limit		●			
Energy consumption monitoring		●			
Energy saving mode with ERV		●			
AI Comfort	●				
AI Diagnostics	●				
Maintenance					
SD slot		●			
AP mode (WiFi setting)	●				

Features and Dimensional drawings

Individual Control System

Wireless Remote Controller AR-CH01E

NEW

- Operation ON/OFF control
- Mode (Auto, Cool, Fan, Dry, Heat)
- Operation temperature setting
- Air flow direction
- Fan speed control
- Indoor unit option code setting

- Auto Clean
- Motion detection
- Freeze wash
- Lighting/ Beep
- ON/OFF timer
- Good Sleep
- AI Features
- AI Comfort
- AI Diagnostics
- Power & Dimensions:
- 0.95 inch OLED display
- Charging via SolarCell & USB-C type
- Net dimensions (W x H x D): 35 x 160 x 13mm



Options (depends on selected model code)

- Option/Setting selection/ Model selection (Standard/360)
- WindFree™ cooling function
- Long wind/Quiet/Purify/Turbo fan speed
- Filter replacement alarm reset
- Heating range (Temperature control in heat mode 8°C to 30°C)
- Individual blade control

Wireless Remote Controller AR-EH03E / AR-EH03M / AR-EH04E

- Operation ON/OFF control
- Fan speed control
- Operation temperature setting
- WindFree™ Cooling function
- Filter cleaning alarm reset
- Air swing control
- Simple ON/OFF timer
- Indoor unit option code setting
- Option/Setting selection

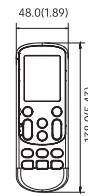

48.0(1.89)

27.8(1.09)

138.0(5.43)

Wired Remote Controller MWR-WG01JN, MWR-WG01KN

NEW

Air conditioner/ERV control

- AC control: ON/OFF, operation mode, temperature setting, fan speed, airflow direction
- ERV control: ON/OFF, operation mode, fan speed
- AC/ERV error monitoring
- Filter cleaning alert and reset alert time
- Control a maximum of 16 "Indoor unit + ERV" in a group with a single wired controller

User convenience function

- Child lock
- Different button permission levels
- Room temperature display
- Dual set point
- Built-in room temperature sensor
- Real-time clock: displays current time and day (summer time support)
- Multiple language support
- Service mode support
- Indoor unit cycle data monitoring
- Indoor unit option code setting and monitoring
- Indoor unit address setting and monitoring
- SD card slot

Energy saving operation

- Upper/lower temperature limit setting
- Automatically stops operating when not used for certain period of time as set by user

Weekly operation schedule setting

- Weekly operating schedule (A/C only, ERV only, A/C+ERV)
- Set desired AC operation mode, temperature and fan speed to operate based on a weekly schedule
- Apply schedule exception day
- Energy consumption monitoring
- Operation time limit

Available languages

- MWR-WG01JN: English, French, Spanish, Portuguese, Dutch, German
- MWR-WG01KN: English, Italian, Greek, Czech, Slovak, Polish

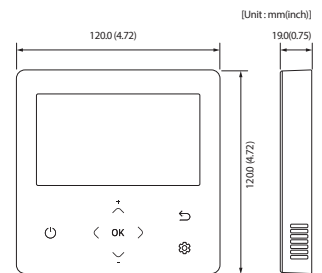

(Unit: mm(inch))

1200(4.72)

190(0.75)

1200(4.72)

Simple Type Controller MWR-SH00N

- Simplified wired remote controller
- AC operation ON/OFF control
- Fan speed control
- Setting operation mode and temperature
- Reset filter cleaning alert indicator
- Adjust airflow direction
- Operation ON/OFF timer function

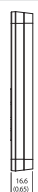
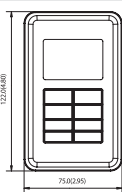

1200(4.72)

750(2.95)

14.5(0.57)

Touch Controller MWR-SH11N

- Bigger display: clear & bright backlight screen with big fonts
- WindFree™ button: control WindFree™ function with just one click
- Room temperature monitor and room temperature display thanks to the built-in temperature sensor
- Icon/Function Lock: option of restricting icon/function on the display
- Sleep Mode: help users to sleep better by controlling temperature
- Outing Feature: keep room temperature above/below specific set value when the user is out of the room

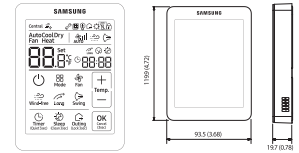

Wireless Receiver Kit MRK-A10N

- Concealed wireless signal receiver
- Filter cleaning sign
- Fan operation display
- Operation Timer setting display
- Operation ON/OFF button
- Operation On display LED (blue)
- Defrost operation display LED (red)

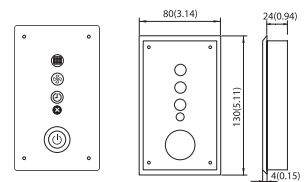

ON/OFF Controller MCM-A202DN

- Maximum 16-group controller (Max. 128 units)
- Whole/Group/Individual indoor unit control (ON/OFF)
- Restriction on the use of wireless/wired remote controllers and external contact control
- Cooling and heating mode control
- Indoor unit error display

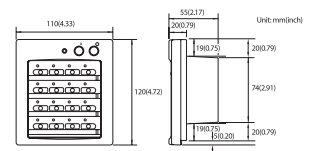

Touch Centralised Controller 2.0 MCM-A300BN

- Large Display: 10.1 inch touch LCD controller
- Ease of use: Provides a familiar user experience by applying the SmartThings UI style
- Simple and modern design (Slim bezel 15mm, Resolution (pixels) : 1280 x 800 (TFT LCD))
- Harmony with interior, easy to select background image
- Controls max. 128 indoor units
- Can display energy usage for each device (Hour/Day/Week/Year) **NEW**
- Set detailed schedule according to each zone and indoor unit
- History of error helps to check the cause of failure and take quick action
- 2D Layout **NEW**
- Remote control by PC/Tablet (In-site) **NEW**
- Net dimensions (W x H x D): 245.7 x 164.5 x 30.9 mm



Wi-Fi Kit 2.0 MIM-H04EN

- Enhanced Convenience
- Voice Control available through a smartphone with Bixby
- Connected home with affordable units in every home using SmartThings
- Welcome cooling and heating based on Geo-fencing
- Individual indoor unit control
- Personalized Climate Environment
- Preferred automation
- Multi-device experience interoperable with smart appliances

- Energy Usage Monitoring
- Current and daily, weekly or monthly energy usage* of the outdoor unit
- Provides ease of installation
- Easy set-up possible for up to 16 indoor units at once
- Net dimensions (W x H x D): 185 x 130 x 29 mm



Module Controller MCM-A00N

- DVM CHILLER ON/OFF control (Module/Group)
- Operation mode, water outlet temperature setting
- Optional operation setting
- Module/Group setting
- Weekly operation schedule setting

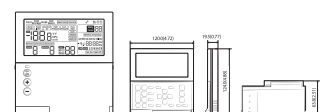

Integrated Control Systems

DMS 2.5 MIM-D01AN

- Built-in web server for PC-independent management and remote access control
- Multiple upper-layer control access (S-NET 3, Web-client)
- Weekly/Daily schedule control
- Power distribution function
- Current time management even during power failure (for 24 hours)
- Emergency stop function with simple contact interface
- Individual/Group control of up to 256 indoor units, AHU and ERV
- User editable control logic
- Accessible level management.
- Dynamic security management
- Operation & error history management
- Data storage in non-volatile memory & SD memory
- Net dimensions (W x H x D): 240 x 255 x 65 mm

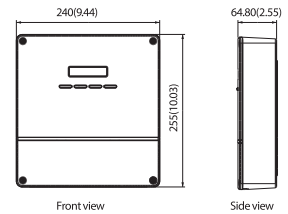

b.IoT Lite Software MST-BL1A

- Integrated building management solution for operational convenience and energy savings
- Open platform which enables integrated control such as DVM, 3rd party devices via BACnet interface
- Suitable for small & medium sized buildings
- Management and remote access control up to 4000 points
- Convenient control authority setting up to maximum 100 clients
- Easy UI experience, HTML5-based Dashboard with a quick overview of customized data for each user
- Operation & error history management: Information on the operation of indoor and outdoor
- units can be stored in graphs or Excel.
- Weekly/Daily schedule control
- 2D layout overview provides location-based intuitive monitoring by visualizing the location of DVM on the drawings of each building and floor.
- Individual/Group/Zone control
- Intelligent Energy Management help to provide more precise energy saving with data-based intelligent controls via algorithms, energy leakage detection and energy distribution

- Energy consumption trend/ energy target setting/tenant based power usage
- Data-based comfort control prevents overcooling/overheating by calculating the proper temperature in consideration of climate and human factors (clothing and activity)
- AI learning based pre-cooling/heating energy saving control predicts time to reach target temperature by learning temperature change and air conditioner setting
- Price Response Control helps to reduce energy consumption and operation costs by controlling indoor temperature and outdoor unit performance by responding to the rates fluctuating by the time of the day.
- Mandatory Hardware requirements: 2.5 GHz CPU, min 32GB RAM, Hard disk or SSD with capacity of 2 TB, 10/100/1000 Base-T(RJ-45 Connector) LAN Card and 1920 x 1080 resolution Display
- Mandatory Software requirements: Windows 10/11 64-bit Chrome browser is recommended (60.x.x.x or newer)



Gateway & Interfaces

BACnet Gateway MIM-B17BN

With the BMS control and monitoring function, BACnet gateway makes it easy to control the air conditioning network in various ways. BACnet gateway can control up to 256 indoor units.

- Interface for BACnet management system
- Maximum of 256 indoor units plus ERVs, supported by a maximum of 80 interface modules
- Includes DMS 2.5 functions

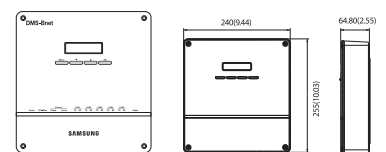

LonWorks Gateway MIM-B18BN

LonWorks gateway is an interface for Lon-Connection to the LonWorks management system, providing you with a more convenient way to manage your air conditioning system. It can control a maximum of 128 indoor units.

- Exclusive use for DMS 2.5 power distribution
- Connection with up to eight watt-hour meters
- Pulse interface with watt-hour meters
- Watt-hour meter - by third party

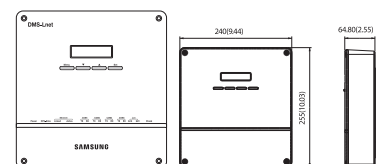

Modbus Interface Module MIM-B19N

A BMS or 3rd controller can control a Samsung SAC by using the Modbus protocol.

- BMS unit protocol: Modbus RS485 (2 wires, max. 1,000 m)
- Unit connection protocol: Samsung Control Layer Protocol (R1/R2)
- Max. No. of connection units: 1 outdoor unit (4 outdoor units including sub units in the case of modular installation) and 48 indoor units
- Modbus interface module address range : up to 247
- Net dimensions (W x H): 50 x 80 mm

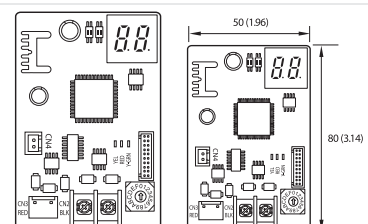

**External Contact Interface Module
MIM-B14**

Samsung Guestroom Management System saves users the energy and money wasted on cooling an unoccupied room. The air conditioner is activated when the Key-Tag is in place and turns off when the Key-Tag is removed. An external contact interface module provides direct indoor unit control via an external contact signal, as well as window-synchronised indoor unit control. The emergency control function features simple contact input. The module also generates indoor unit operation/error state output through relay contacts.

- Direct indoor unit control by external contact signal
- Window-synchronised indoor unit control
- Emergency control with simple contact input
- Indoor unit operation/error state output through relay contacts

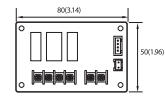
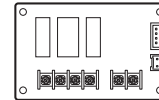

**Refrigerant Leak Detect (RLD) Interface Module
MIM-B14A**

The RLD Interface Module is an interface module that has 2 outputs and 1 input. It is mainly applied to the Refrigerant Leak Detector system.

- RLD Interface Module function
- To send a refrigerant leakage detection signal from a master DDC to an outdoor unit
- To send a outdoor pump down operation status signal from an outdoor unit to a master DDC
- Net dimensions (W x H x D): 50 x 80 x 35 mm

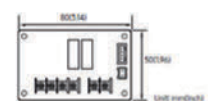
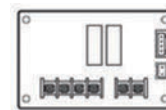

**PIM (Pulse Interface Module)
MIM-B16N**

- The Watt-Hour Meter Interface Module can be exclusively used for DMS 2.5 power distribution, displaying power consumption for each watt-hour meter.
- Exclusive use for DMS 2.5 power distribution
- Connection with up to eight watt-hour meters
- Pulse interface with watt-hour meters
- Watt-hour meter - by third party

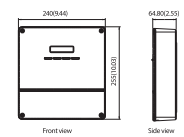
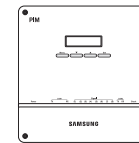

**Interface Module
MIM-N01**

- Communication interface module between outdoor units and the upper level controller which makes use of a different type of communication
- Connect one interface module to one outdoor unit
- Individual control - maximum of 48 indoor units
- Group control - maximum of 16 groups
- Automatic detection of communication type: determine the communication type used by the upper level controller according to the communication type used by the outdoor unit
- Supported communication type
 - Conventional outdoor unit communication ↔ New upper level controller communication
 - New outdoor unit communication ↔ Conventional upper level controller communication

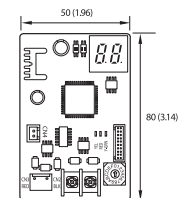
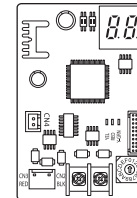

**FCU Interface Module
MIM-F10N**

- Communication interface module
- Connect one FCU interface module to a maximum of 16 FCU Kits.
- Supports FCU Kit only

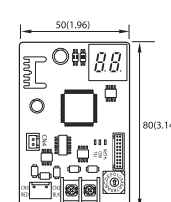
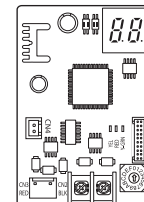

**FCU Kit
MIM-F00N**

- For 3rdParty FCU
- Communication and control interfacing kit between 3rd party FCU and Samsung control system
- Possible to use wired remote controller
- Possible to use DMS 2.5, touch centralized controller
- Provides external contact input
- Outputs control signal for FCU fan/water valve
- Size: 270 x 200 x 87.4mm (W x H x D)



**Interface Module (Converter RS485 to NASA)
MIM-N10**

- Communication interface module between new communication ERV and controller
- Connect one ERV interface module to a maximum of 16 ERVs
- Individual control - maximum of 16 ERVs
- Group control - maximum of 16 groups
- Supported communication type
 - Conventional ERV communication ↔ New upper level controller communication
 - New ERV communication ↔ Conventional upper level controller communication
 - New ERV communication ↔ New upper level controller communication

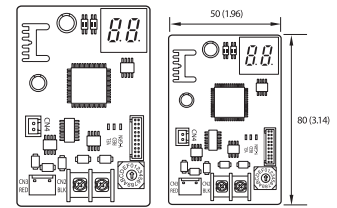

Installation/Test Run Solution

**S-Converter
MIM-C02N, MIM-S10N (TBD)**

- Communication converting module to connect Samsung system air conditioner to a PC.
- Main purpose for use
 - To connect with test run programme [Test run programme]
 - S-NET Pro: Conventional communication
 - S-NET Pro2: NASA communication

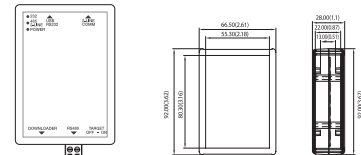

Others

**External Room Sensor
MRW-TA**

- Indoor unit is operated by MRW-TA instead of its own sensor.
- Wire length: 12 m

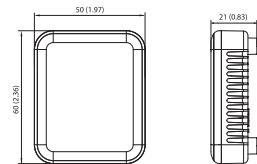

**Operation Mode Selection Switch
MCM-C200**

- Outdoor unit operation mode selection (Cooling, Heating or Auto)
- Mixed operation mode protection

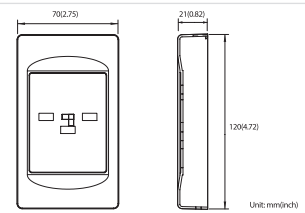

**MTFC (Multi-Tenant Function Controller)
MCM-C210N**

- Multi-tenant function controller is an auxiliary power supply device which allows the indoor unit to turn off (close EEV) normally and maintain communication when the mains power supply is cut.
- It is used on sites such as hotels, where individual power is supplied to the indoor unit

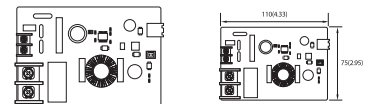

**Base heater Control Kit
AVR-M200GHAX**

- Only Compatible with DVM S2 base heaters (MHC-013VE1 and MHC-015VE1)

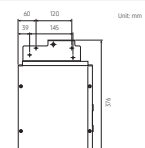
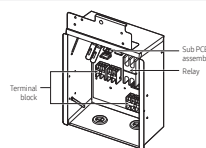

Accessories



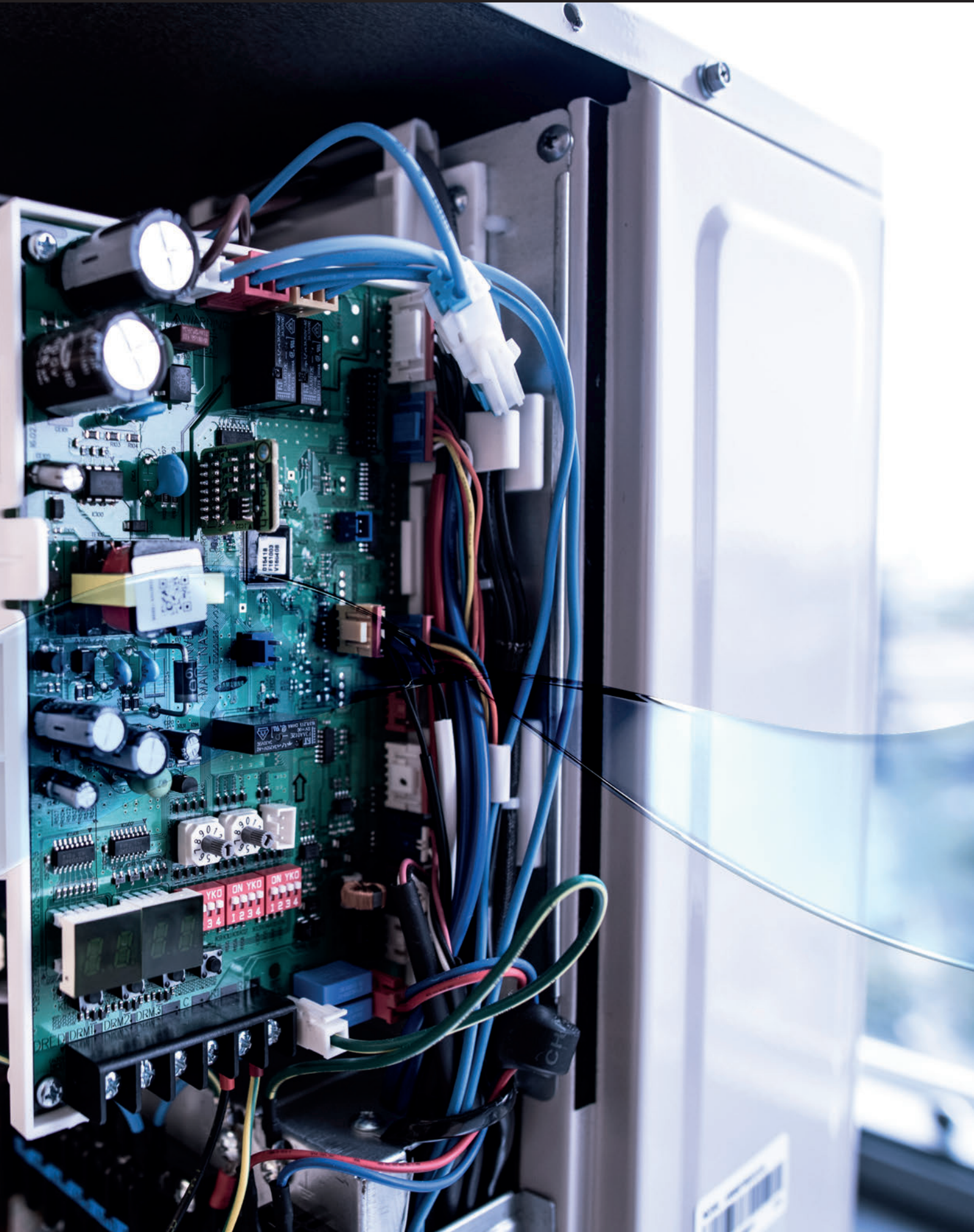

Line-up panels

360 Cassette Front Panel



White Circle (Exposed installation) Black Circle (Exposed installation) White Square Black Square

Motion Detect Sensor



Standard	PC4NUNMAN	PC4NBNMAN	PC4NUDMAN	PC4NBDMAN	MCR-SME
Standard Air Purification	PC6EUCMAN	-	-	-	
Standard Auto Elevation	PC6EUXMAN	-	-	-	
Universal SmartThings	PC6EUSMANW	PC6EBSMANW	PC6NUSMANW	PC6NBSMANW	
Universal SmartThings Air Purification	PC6EUCMANW	-	-	-	
Universal SmartThings Auto Elevation	PC6EUXMANW	-	-	-	

NEW



WindFree™ 4-Way Cassette Front Panel



600x600 Mini White 900x900 White 900x900 Black

Motion Detect Sensor



900 x 900 600 x 600
MCR-SMC **MCR-SMD**

Standard	PC4SUFMAN	PC4NUFMAN	-
Standard Air Purification	-	PC4NUCEAN	-
Standard Auto Elevation	-	PC4NUXMAN	-
Universal SmartThings	PC4SUFMANW	PC4NUFMANW	PC4NBFMANW
Universal SmartThings Air Purification	-	PC4NUCMANW	-
Universal SmartThings Auto Elevation	-	PC4NUXMANW	-

NEW



WindFree™ 1-Way Cassette Front Panel



1.7-2.2 kW 2.8-3.6 kW 5.6-7.1 kW





Standard	PC1MWFMAN	PC1NWFMAN	PC1BWFMAN
FCU	-	PC1NWFMBN	PC1BWFMBN
Universal SmartThings	PC1MWFMANW	PC1NWFMANW	PC1BWFMANW
Universal SmartThings Air Purification	PC1MWCMANW	PC1NWCMANW	PC1BWCMANW





NEW



New Panel model codes ending with W in blue color are equipped with a factory-integrated Wi-Fi kit (MIM-H14EN), enabling seamless management of indoor units directly through the intuitive SmartThings App

*Only compatible with Universal DVM and CAC HEE Indoor Units.

Classification	Image	Model	Application
Drain Pump		MDP-N0475NC1D	HSP Duct (22.4/28.0 kW) Fresh Air Intake Duct (14.0 kW)
		MDP-M075SGU2D	OAP Duct for DVM S
		MDP-G075SP	Global Duct (External Type)
		MDP-G075SQ	Global Duct (Internal Type)
AHU Kits		MXD-K025AN	EEV + Control Kit (7.00–8.75 kW AHU)
		MXD-K050AN	EEV + Control Kit (14.00–17.50 kW AHU)
		MXD-K075AN	EEV + Control Kit (21.00–26.25 kW AHU)
		MXD-K100AN	EEV + Control Kit (28.00–35.00 kW AHU)
		MXD-A64K100E	AHU EEV Kit (10 HP)
		MCM-D201N	Control Kit (PBA, 10 HP–40 HP)
Y-joint		MXJ-YA1509M	15.0 kW and below
		MXJ-YA2512M	Over 15.0 kW–40.0 kW and below
		MXJ-YA2812M	Over 40.0 kW–45.0 kW and below
		MXJ-YA2815M	Over 45.0 kW–70.3 kW and below
		MXJ-YA3419M	Over 70.3 kW–98.4 kW and below
		MXJ-YA4119M	Over 98.4 kW–135.2 kW and below
		MXJ-YA4422M	Over 135.2 kW
Y-Joint (HR Only)		MXJ-YA1500M	22.4 kW and below
		MXJ-YA2500M	Over 22.4 kW–70.3 kW and below
		MXJ-YA3100M	Over 70.3 kW–135.2 kW and below
		MXJ-YA3800M	Over 135.2 kW
Y-Joint (Outdoor Unit)		MXJ-TA3419M	135.2 kW and below
		MXJ-TA4122M	140.2 kW and over
Y-Joint (HR Outdoor Unit)		MXJ-TA3100M	135.2 kW and below
		MXJ-TA3800M	140.2 kW and over
Y-Joint (for MCU)		MXJ-YM1509M	Over 16.0 kW–28.0 kW and below
		MXJ-YM1206M	Over 6.0 kW–14.0 kW and below
		MXJ-YM1206R	Over 6.0 kW–14.0 kW and below
Distribution Header		MXJ-HA2512M	45.0 kW and below (for 4 rooms)
		MXJ-HA3115M	70.3 kW and below (for 8 rooms)
		MXJ-HA3819M	Over 70.3 kW–135.2 kW and below (for 8 rooms)
Heat Recovery Changer		MCU-R4NEK0N	
		MCU-S6NEK3N	

Classification	Image	Model	Application
MCU		MCU-S12NEK1N	12 ports, max 61.6 kW (~16 kW/port)
		MCU-S8NEK1N	8 ports, max 61.6 kW (~16 kW/port)
		MCU-S6NEK2N	6 ports, max 61.6 kW (~16 kW/port)
		MCU-S4NEK3N	4 ports, max 61.6 kW (~16 kW/port)
		MCU-S2NEK2N	2 ports, max 32.0 kW (~16 kW/port)
		MCU-S1NEK1N	1 ports, max 16.0 kW (~16 kW/port)
EEV Kit		MXD-E24K132A	2 Indoor
		MXD-E24K200A	
		MXD-E32K200A	
		MXD-E24K232A	3 Indoor
		MXD-E24K300A	
		MXD-E32K224A	
		MXD-E32K300A	
		MEV-E24SA	1 Indoor
		MEV-E32SA	
DRAIN HOSE		MOK-200DA	L TYPE SLIM 1-WAY / 4-WAY MINI
Differential Pressure Switch		MOS-P1050	ERV (Plus)
CO ₂ SENSOR		MOS-C1	ERV (Plus)
Base-heater Kits		MHC-015EE	DVM S Eco HR, DVM S Mini R32
		MHC-013VE1	DVM S 2 Small
		MHC-015VE1	DVM S 2 Large
PDM (Pressure Drop Modulation) Kit		MXD-A38K2A	8 – 12HP
		MXD-A12K2A	14 – 16HP
		MXD-A58K2A	18 – 26HP
3rd party FCU Accessories		ACL-A60V3	3-Way Valve Kit
		ACL-ADP	Drain pipe
		ACL-A0**HC	Heating coil 4-pipe
		ACL-A0**V3	3-Way Valve Kit 4-pipe
		ACL-ADV	Auxiliary Drain Pan Vertical
		ACL-ADH	Auxiliary Drain Pan Horizontal



Design and support





Samsung Climate Solutions Partner Portal

As one of Samsung's registered Climate Solutions partners, you will have access to our Partner Portal and its many benefits. Whether you are looking for technical product documentation, requesting technical support or registering for training, the Samsung Climate Solutions Partner Portal offers you everything you need to consistently deliver the best results.

Access technical resources

The Technical Resources section provides you with all of the relevant information you need to understand the product's functionality and to prepare and design projects. A library full of

technical information is at your fingertips, ranging from technical data books, BIM files and certificates to exploded views, drawings and different kinds of manuals.

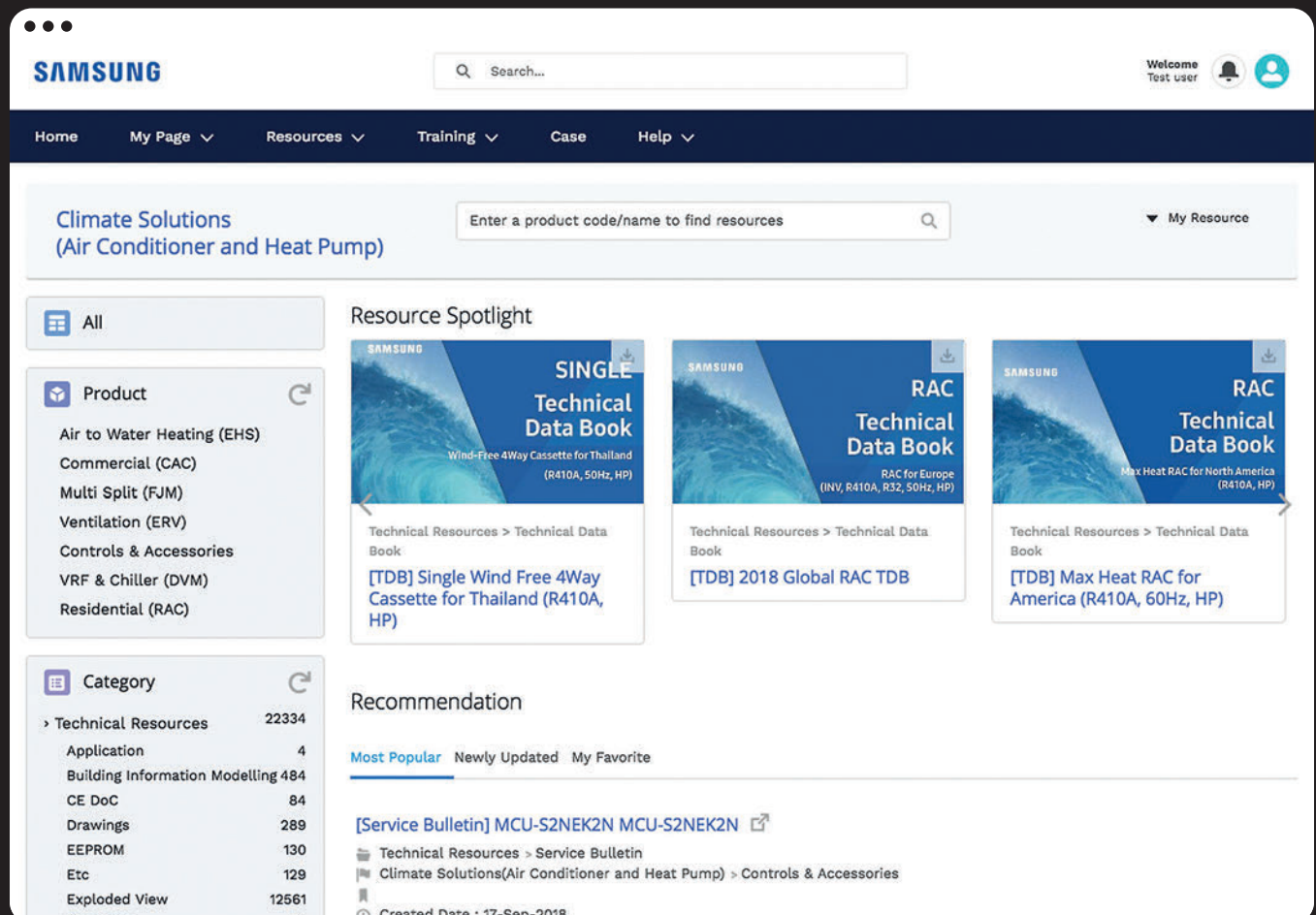

Request technical support

You can easily request technical support through the Samsung Partner Portal by reporting your case using our built-in ticketing system. You can rest assured that our well-trained technical experts will work to solve your issue as soon as possible.

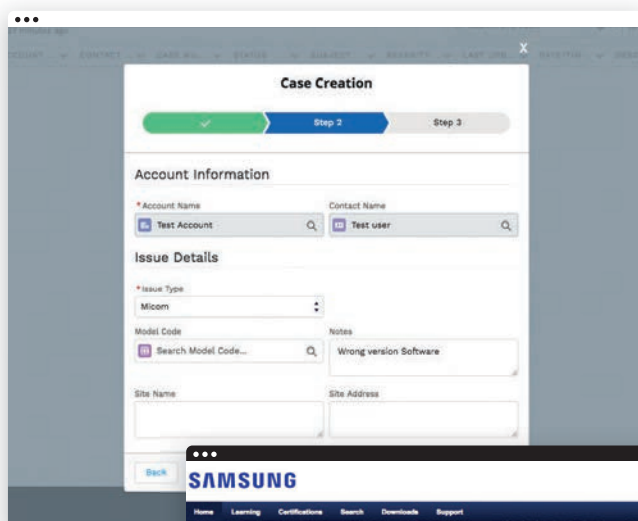

Register for training

If you are dedicated to becoming a Samsung climate solutions expert, you can access Samsung's educational portal for training sessions provided by experienced trainers. The portal allows you to search for online courses and materials, test your climate solutions knowledge, and more. The Samsung Business Academy is here to help you succeed.¹

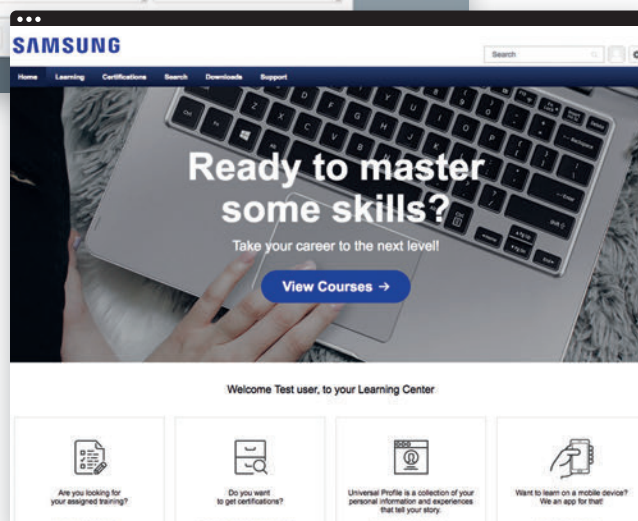

¹ The registration process for and availability of training courses may vary per country. Please contact your direct Samsung contact person for more information.

How to access



1. Register

To register for the Samsung Climate Solutions Partner Portal, open your web browser¹ and go to partnerhub.samsung.com/climate to complete the registration form.



2. Access

Your information will be verified and your account will be activated. You will receive your personal login details.



3. Manage account

Keep your account details up to date and invite your colleagues to join.



4. Search and download

Access a full library of resources, request technical support, or sign up for a Climate Solutions Academy training session.

¹ Google Chrome is the recommended web browser for using the Samsung Climate Solutions Partner Portal.

Samsung DVM Pro 2.0

Samsung DVM Pro 2.0 is an advanced design automation programme which helps you to select the most suitable equipment for easily and precisely designing your HVAC system. It helps to ensure that the system's design falls within Samsung's engineering guidelines. With its reports, pipe and wire diagrams, additional refrigerant values and other information, Samsung DVM Pro 2.0 is a powerful tool for engineers, designers or installers.

Sales Mode

Sales Mode enables users to define their requirements and select air conditioning products quickly and easily.

Product selection

List of equipment, including indoor units, outdoor units, controls and accessories

Control systems

Automatic control unit selection

Updated Toolbar

User-friendly tool bar helps to guide intuitively

Piping schematics

Basic or manual selection with system check and capacity simulation

Wiring schematics

Automatic diagrams including communication wiring for indoor/outdoor/control units and electric power meters

Reports

Specifications, diagrams in DWG & BMP format, quotations

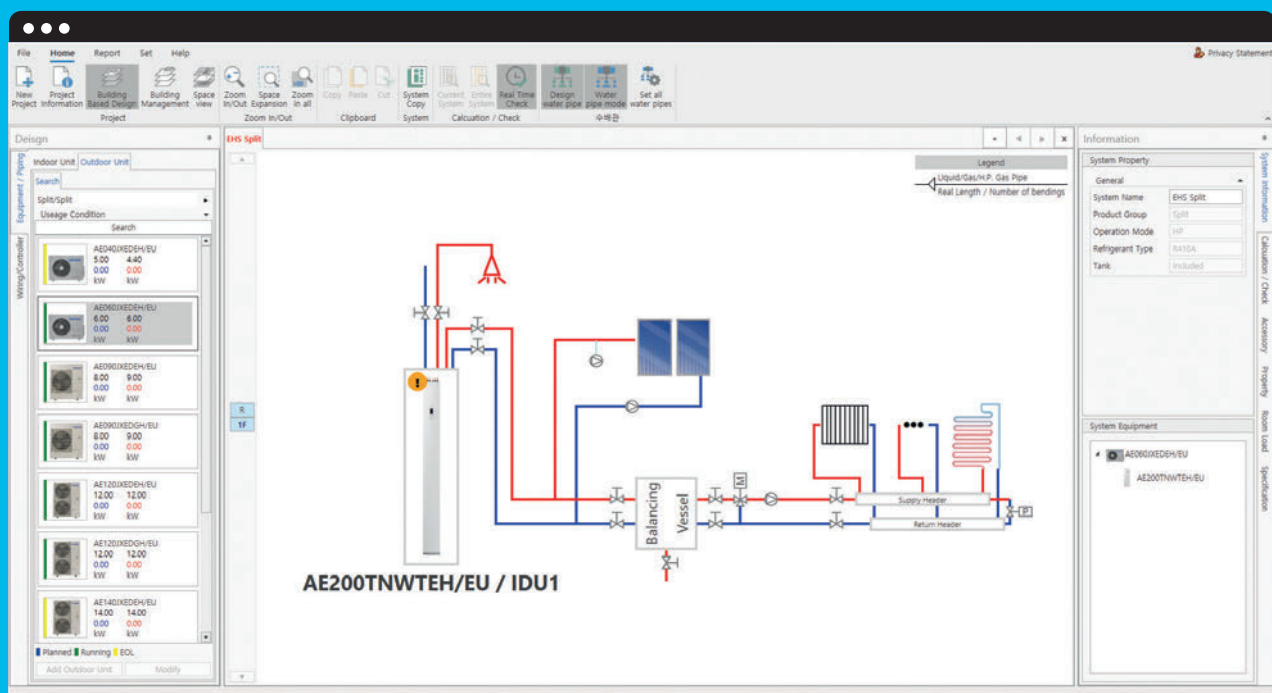

CAD Mode

CAD Mode is an in-depth and precise design tool that enables users to design their air conditioning systems.

Pipe sizing & lengths

Automatic pipe drawing and selection

Automatic selection and report

Piping installation

System check

Installation regulation
& refrigerant charging

Design without AutoCAD

Compatible with AutoCAD and AutoCAD LT for DWG.

Performance simulation

Capacity correction tool against specific design conditions

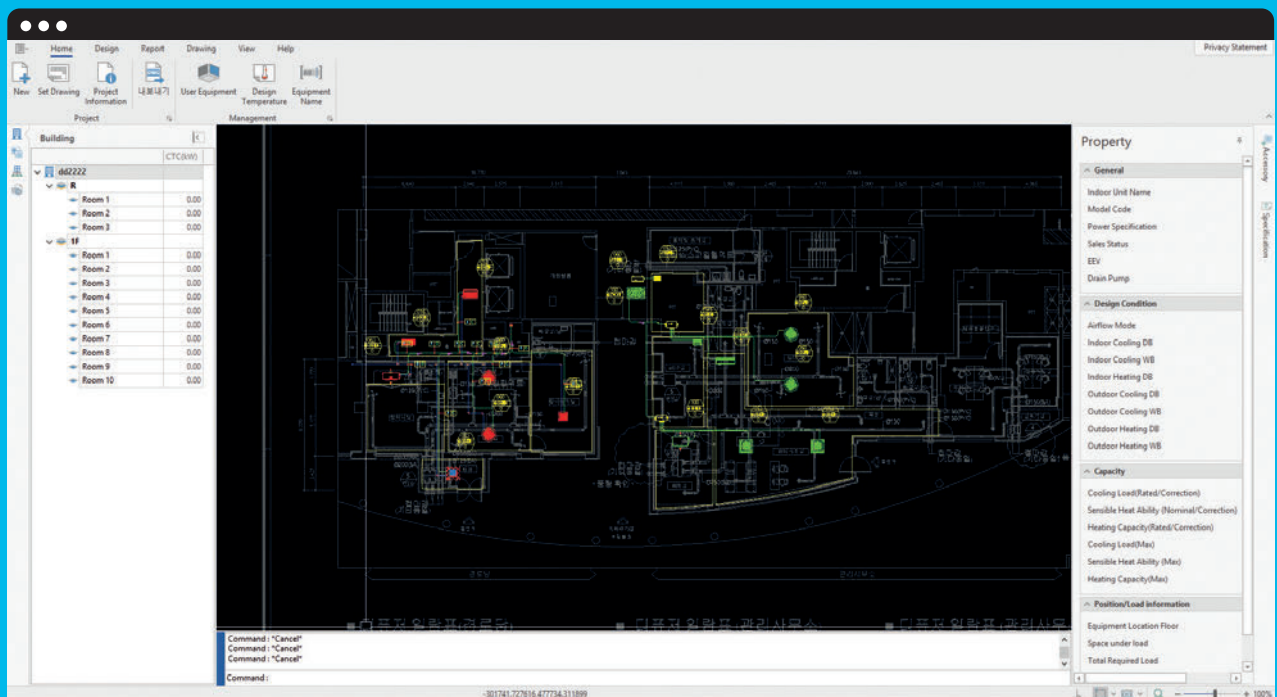

¹ Google Chrome is the recommended web browser for using the Samsung DVM Pro 2.0 Portal.

How to access



1. Register

Go to dvmpro.mkt.samsung.com to access the Samsung DVM Pro 2.0 Portal¹. If you do not have access yet, complete the registration process and you will be sent the access details.



2. Select

Click on DVM Pro 2.0 via the main menu and scroll to the end of the page to select the option DVM Pro 2.0 download.



3. Download

Download the DVM Pro 2.0 installation file, view the user manuals, and start designing your project.

Samsung HVM Selection Tool

To support engineers in designing a Samsung HVM water-based VRF system, Samsung has created an easy-to-use selection tool with convenience in mind. This tool will help you design your whole system in a modular way, simplifying and speeding up the process. The Samsung HVM Selection Tool does not require any software installation and is freely accessible online, giving you a head start in creating and designing your projects for tomorrow.

Easy system configuration

The drag and drop interface of the HVM Selection Tool enables you to configure the HVM system easily and quickly. Based on the configuration selected, the tool generates information such as total water flow and total system pressure drop, enabling you to select the appropriate water pump and piping. Values for cooling and heating are calculated automatically based on the design conditions selected for the project (room temperature, outside temperature, water temperature).

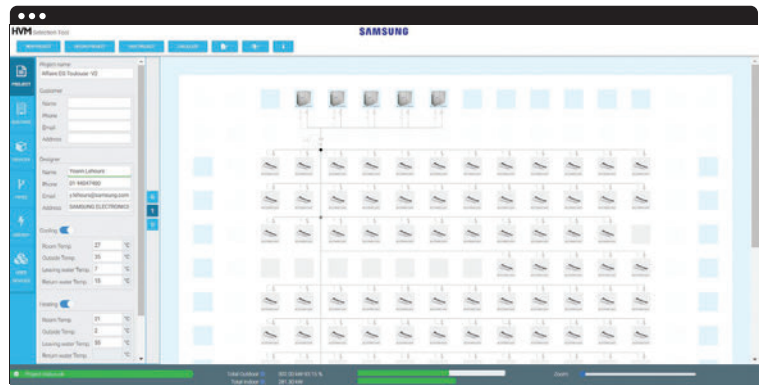

SAMSUNG		HVM	
AG026MN1DEH			
Model name	AG026MN1DEH		
Power supply	1,2,220-240,50/60	SI, R, V, Hz	
Capacity			
Tot. Cooling Capacity at selection:	2.28	kW	
Stm. Cooling Capacity at selection:	1.79	kW	
Room temperature Cooling @ 50Fh.r.:	37	°C	
Heating Capacity at selection:	3.2	kW	
Room temperature heating:	21	°C	
Cooling mode water temperatures:	7 / 15.0	°C	
Heating mode water temperatures:	35 / 43.3	°C	
Power:			
Power input:	47	W	
Current input:	0.24	A	
Fan:			
Type:	Crossflow Fan		
Motor:	AC		
Number of Units:	1		
Air flow rate W(V), (U.S.):	6.8/5.8/4.8	m ³ /min	
Specific fan power:	0.425	W/(l/s)	
Piping connections:			
Thread:	3/4"	PP male	
Field wiring:			
Power Source wire:	1.8-2.3	mm ²	
Transmission Cable shielded:	0.75-1.50	mm ²	
Coil:			
Water flow at selection:	0.245	m ³ /h	
Pressure drop at selection:	7.4	kPa	
Sound:			
Sound Pressure (High / Mid / Low):	33/30/28	dB(A)	
Sound Power:	49	dB(A)	
External dimensions:			
Net weight:	13.5	kg	
Shipping weight:	13.5	kg	
Net dimensions (mm)(D):	970x180x410	mm	
Shipping dimensions (mm)(D):	1170x331x487	mm	
Pipe:			
Type:	PC110USMAN		
Net weight:	3.3	kg	
Shipping weight:	6.4	kg	
Net dimensions (mm)(D):	1180x28x500	mm	
Shipping dimensions (mm)(D):	1350x54x042	mm	
Drain pump:			
Max. lifting height:	780	mm	
Filter:	Microlifeout Filter		

Complete technical information

The HVM Selection Tool includes a detailed list of available outdoor Samsung HVM chiller units and indoor FCU units. It also includes an overview of accessories and essential hydronic components, and features the required efficiency data (SCOP, COP, SEER and EER). To enable the preadjustment of balancing valves, the detailed list of indoor units shows the water flow, pressure drop and pressure difference data for the water line holding the highest pressure drop.

SAMSUNG **HVM**

Equipment List

Outdoor Devices

Model Name	Quantity	Cooling Total capacity (kW)	Cooling Elec. Cons. (kW)	Heating Total capacity (kW)	Heating Elec. Cons. (kW)
AG042KSVANH	1	42.00	11.13	34.89	12.91
AG070KSVANH	4	68.00	25.93	39.79	26.62
Total	5	110.00	37.06	74.68	39.53

Indoor Devices

Model Name	Quantity	Cooling Total capacity (kW)	Cooling Sens. capacity (kW)	Heating Total capacity (kW)	Heating Elec. Cons. (kW)
AG026MNVDEH	35	2.28	1.79	3.20	
AG032MNVDEH	65	3.10	2.39	3.81	
Total	100	261.30	218.00	359.85	

Valves

Type	Quantity
3 way valve-R1 (incl. shutoff and balancing valve)	20
2 way valve-R1 (incl. shutoff and balancing valve)	20
Shutoff valve (outdoor unit -see system diagram)	6
Balancing valve (outdoor unit -see system diagram)	5
Control valve (outdoor unit -see system diagram)	5

Accessories

SAMSUNG **HVM**

Outdoor Devices

AG070KSVANH
Quantity: 4 pcs.

SUPER HVM-S
Water VRF heat pumps outdoor unit - AG070KSVANH
Suitable for modular installation up to 8 modules in a water circuit with DVM-S inverter technology, with flash gas injection and NASA communication, for cooling or heating.

Features:
Eurovent certified, HVRF outdoor unit with water as a carrier medium for monovalent operation for all-year heating or cooling operation. The asymmetric inverter Scroll compressors with intermediate injection and micro-frequency control guarantee continuous variable power control from 20-100 Hz with minimal starting current. Water / brine flow temperatures from -10 °C to +35 °C. Adjustable in control stage of 0.1 °C. Low-noise night mode, adjustable in three stages from -3 to -9 dB (A). Outstanding efficiency due to generously dimensioned heat exchanger surfaces and optimized asymmetric scroll compressors with integrated flash gas injection in heating mode. Intelligent control system for 3 individually adjustable function modes (rotation, simultaneous or energy-saving operation). Sequential and intelligent defrost operation (with modular installation) guarantees consistent heating performance. Contacts for the output of an error message and compressor status as well as input contacts for remote on / off and quiet mode.

Reliable, fast and stable Samsung's internal data bus system (NASA): 3 control levels without additional interface. Maintenance-friendly e.g. Pump-down function, self-diagnostic system with data backup (operating conditions of the last 30 minutes are stored in the system for error analysis). Auto-restart (restarting after power failure). ACM commissioning and management via smart phone, tablet or PC. Possibility for RUGS monitoring via internet / Mobile App.

Operating limits:
Cooling operation is possible at an outdoor temperature of -15 °C to +48 °C, heating operation from -20 °C to +24 °C.

Unit design:
Weatherproof sheet steel housing on torsion-resistant base frame for outdoor installation. Equipped with Smart DSI Inverter Scroll Compressor, Vibration Damper, Micro frequency control, step-less from 20-100Hz, Very low starting current. Especially quiet and efficient. Integrated winding protection, silent mode fan for quiet operation, directly driven, electronically balanced, vibration damped, vertical air outlet with up to 80 Pa external static pressure. Including 4-way reversing valve for heat pump operation. Crankcase heater: 2 in series, highly efficient plate heat exchangers (stainless steel plates, CU-soldered) together with the integrated economizer ensure highest efficiency values. The inverter modules are cooled via the refrigerant circuit in order to avoid harmful temperature fluctuations via outside air cooling. Refrigeration system factory pre-filled with safety refrigerant R410A.

Backup function:
The system is equipped with a backup function. In the event of a malfunction, the operating data can be recalled as a backup file for the last 30 minutes prior to a system failure. All device configurations and settings made during commissioning are permanently stored on a data chip.

Optional system connection to building management systems:
The system connection to building management systems, e.g. LonWorks, BACnet Modbus is possible.

Optional energy recording and billing:
With the CMS meter and the meterlock MMS16N an approved energy recording is possible.

Technical data (Eurovent certified):

Model name AG070KSVANH
Power Supply: 3, 4, 160-415, 50/60 Hz, R, Y, RZ
Model: Rev. heat pump

Capacity
Cooling capacity at selection: 65.0 kW
Operating conditions Cooling Outside temp.: 35 °C

Alfena 33, September 13 Copyright © 2015 Samsung Business Air Conditioner Europe BV. All rights reserved. Samsung is a registered trademark of Samsung Electronics Co., Ltd. Page 3
Rev. 27 Aug. 2015

Automated project report

You can opt for a comprehensive annual energy consumption simulation, based on a fixed set of parameters and the climate zone selected for the heating mode (warm, average, cold). High resolution PDF documents can be generated showing the wiring diagrams and hydraulic diagrams for indoor units and outdoor units, including the pipe dimensions. The detailed project report is presented in a layout that is easy to understand.

Tender specifications file

A tender specifications file can be generated that includes full product descriptions, feature explanations and complete technical data. You can also personalise the document by including additional information about the customer and the designer.

How to access



1. Access

To access the HVM Selection Tool, open your web browser¹ and go to **hvm.openforce.com**. No additional software installation is required.



2. Design

Create your project, design the HVM system and generate an automated report and tender specifications file online.



3. Support

If you require support, please consult the manual that can be downloaded directly from the HVM selection tool.

¹ Google Chrome is the recommended web browser for using the Samsung Climate Solutions Partner Portal.

Samsung specialist design support

Bringing together technical expertise and practical experience in climate system design, Samsung provides a single point of contact for the design and management of cooling and heating installations in buildings. With assistance ranging from 3D visualisations with BIM support to CFD analysis to optimise indoor thermal conditions and BREEAM assessments to achieve the best environmental performance, Samsung's specialist engineers are ready to support you in making your project a success.

BIM support

Building Information Modelling (BIM) is an intelligent 3D model-based process for creating and managing information on the physical and functional characteristics of a building, across the project lifecycle and covering all parties involved, including the supply chain. BIM gives architects, engineers and construction professionals the insights and tools necessary to efficiently plan, design, construct and manage buildings and infrastructure.

To support you as one of our Climate Solutions partners, Samsung has developed a full range of BIM models. You can download these BIM files from the Partner Portal.

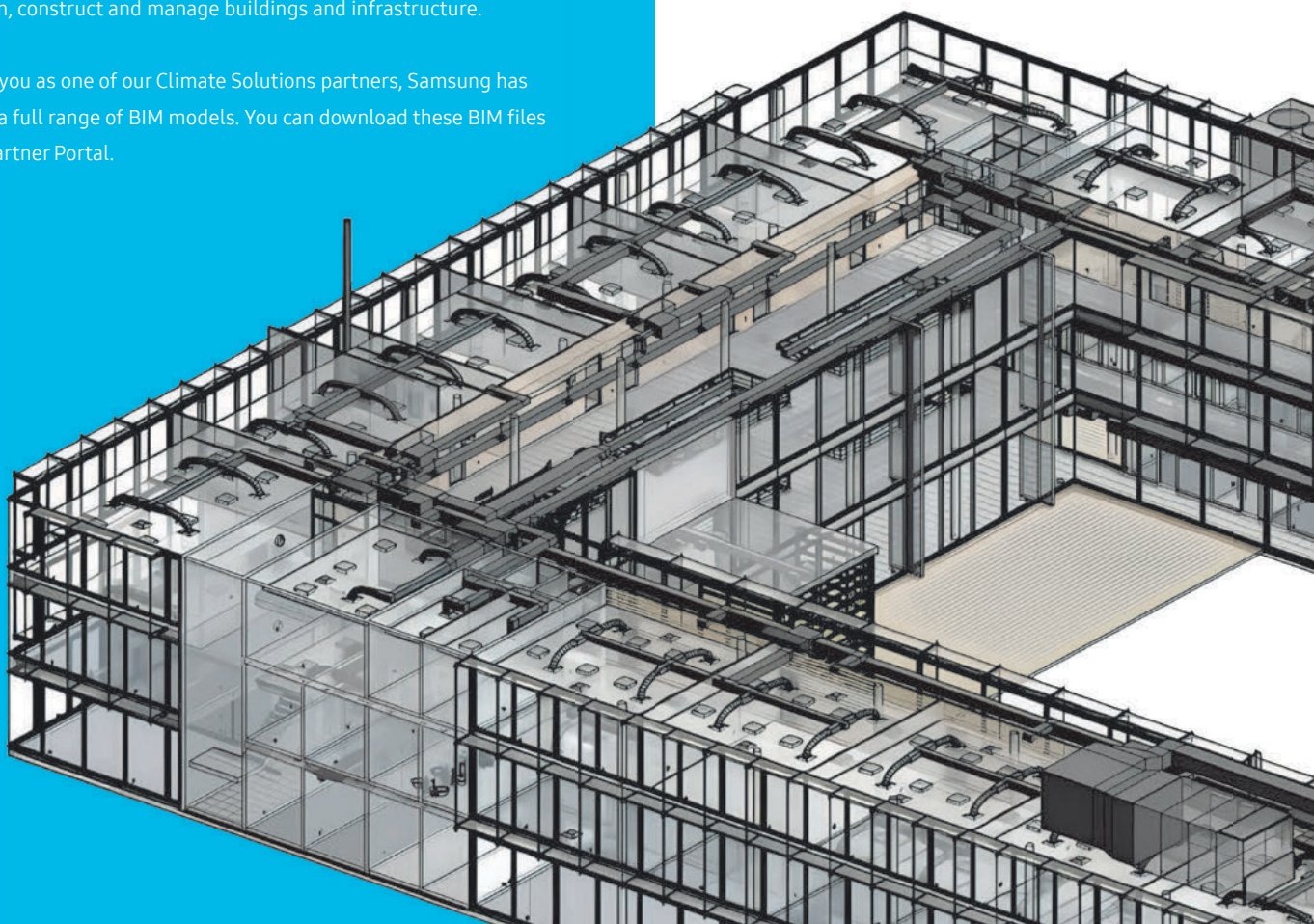

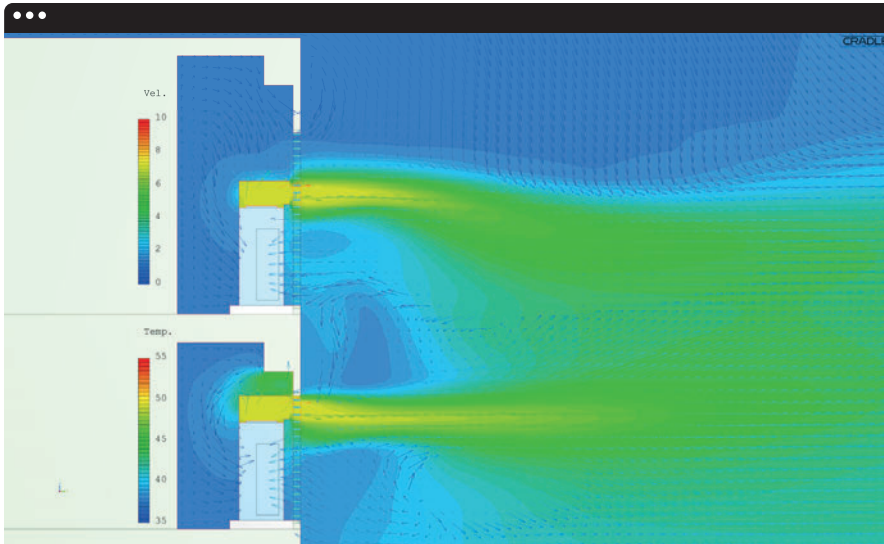

CFD analysis

Computational Fluid Dynamics (CFD) uses numerical analysis and data structures to analyse thermal conditions in buildings. It allows the virtual testing and optimisation of various climate system configurations in the context of occupant comfort, energy efficiency and running cost. Samsung can offer you specialist CFD support that includes analyses such as indoor temperature profiling, airflow distribution and sound simulation.

BREEAM advice

BREEAM (BRE¹ Environmental Assessment Method) is one of the most widely used environmental assessment methods and rating systems for buildings. It sets the standard for best practice in sustainable design and has become the de facto measure used to describe a building's environmental performance. Samsung's Accredited Professionals (APs) can support you in assessing

BREEAM[®]

the optimal installation for achieving a high certification score to match your green building programme.

¹BRE (Building Research Establishment) is a leading, multidisciplinary building science centre based in the United Kingdom.

How to obtain support



1. BIM support

To download Samsung BIM models, go to the Technical Resources on partnerhub.samsung.com/climate¹. To request dedicated project design support from Samsung, please contact your Samsung representative.



2. CFD analysis

Obtain CFD analysis support from Samsung, please contact your Samsung representative. Certain conditions may apply, subject to the project.



3. BREEAM advice

Please contact your Samsung representative to request a BREEAM evaluation by one of Samsung's Accredited Professionals (APs).

¹ Google Chrome is the recommended web browser for using the Samsung Climate Solutions Partner Portal.

Samsung Climate Solutions Academy

Samsung Climate Solutions Academy is committed to providing engineers with the technical skills required to install a Samsung product efficiently, and to help relay necessary information to users. All courses are designed to provide attendees with the opportunity to develop both theoretical and practical knowledge of Samsung's vast range of equipment and solutions.

Available training modules

Essential courses

Basic commercial training

- The product line-up, accessories and available controls
- The unique features of Samsung products
- Installation considerations

1

Advanced courses

Technical training

- How to correctly install and configure a system
- Commissioning: common issues during commissioning and how to resolve any challenges
- Troubleshooting and fault-finding (by use of E-codes)
- Control logic
- Case studies

2

Advanced courses

Design training

- Understanding customers' needs and offering possible solutions
- DVM Pro 2.0 - Samsung's advanced design tool
- Case studies

3

Note: the registration process for and availability of training courses may vary per country. Please contact your Samsung representative for more information.

Samsung training centres in Europe

Amsterdam

The Netherlands

Athens

Greece

Lisbon

Portugal

Lyon

France

Manchester

United Kingdom

Chertsey

United Kingdom

Madrid

Spain

Milan

Italy

Warsaw

Poland

Zagreb

Croatia



How to register for training



1. Select

Go to [partnerhub.samsung.com/](https://partnerhub.samsung.com/climate) **climate** and search the online event calendar to select the training course you want to attend.



2. Register

After identifying the training course you would like to attend, follow the registration process.



3. Participate

You will be trained by one of our specialised Master Trainers or Product Specialists in one of our training centres.



4. Get certified

After completing the training, you will receive a Certificate of Completion.

¹ Google Chrome is the recommended web browser for using the Samsung Climate Solutions Partner Portal.

SAMSUNG

Find your flow.

Create your perfect environment

Learn more about Samsung Climate Solutions at:
samsung-climatesolutions.com

Copyright © 2025 Samsung Electronics Air Conditioner Europe B.V. All rights reserved. Samsung is a registered trademark of Samsung Electronics Co., Ltd. Specifications and designs are subject to change without notice and may include preliminary information. Non-metric weights and measurements are approximate. All data was deemed correct at the time of creation. Samsung is not liable for errors or omissions. Some images may be digitally altered. All brand, product, service names and logos are trademarks and/or registered trademarks of their respective owners and are hereby recognised and acknowledged.



Samsung Electronics Co., Ltd. participates in the Eurovent Certification Programme (ECP) for Air Conditioners (AC), Variable Refrigerant Flow (VRF) and Liquid Chilling Packages Heat Pump (LCP-HP). To check the ongoing validity of certification, please visit: www.eurovent-certification.com

Samsung Electronics Air Conditioner Europe B.V.

Evert van de Beekstraat 310, 1118 CX Schiphol

P.O. Box 75810, 1118 ZZ Schiphol

+31 (0)8 81 41 61 00

The Netherlands